

2-BURNER PATIO GAS GRILL

Model number:

GR2234801-MM-00 / GR2234802-MM-00

ASSEMBLY & OPERATING INSTRUCTIONS

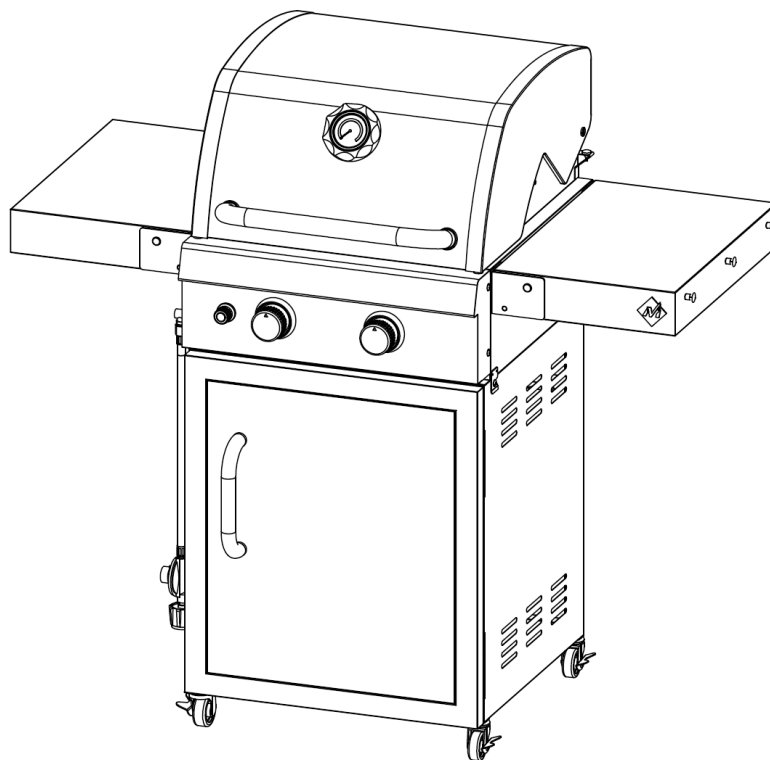

For Outdoor Use Only

- This instruction manual contains important information necessary for the proper assembly and safe use of the appliance.
- Read and follow all warnings and instructions before assembling/using the appliance.
- Failure to follow these instructions and warnings could result in damage to the product or injury to the user.
- Keep this manual for further reference.

Should you encounter any problem,
CALL US FIRST.

DO NOT return product to the retail store!!

WE CAN HELP.

For assistance, contact customer service at customerservice@rankam.com
or at (888) 837-1380, Mon to Fri, 8:00am – 5:00pm Pacific Standard time



WARNINGS

SAFETY LABELS



 **DANGER:** Indicates an imminent hazardous situation which if not avoided will result in death or serious injury.



 **WARNING:** Be alert to the possibility of serious bodily injury if the instructions are not followed. Be sure to read and carefully follow all of the messages.

 **CAUTION:** Indicates a potentially hazardous situation, which, if not avoided, may result in minor or moderate injury.

	DANGER	
<p>If you smell gas:</p> <ol style="list-style-type: none">1. Shut off gas to the appliance.2. Extinguish any open flame.3. Open lid.4. If odor continues, keep away from the appliance and immediately call your gas supplier or fire department.		
<p>Failure to follow these instructions could result in fire or explosion which could cause property damage, personal injury or death.</p>		

	WARNING	
<ol style="list-style-type: none">1. Do not store or use gasoline or other flammable liquids or vapors in the vicinity of this or any other appliance.2. An LP cylinder not connected for use shall not be stored in the vicinity of this or any other appliance.		

	DANGER	
<p>(a) Do not store a spare LP gas cylinder under or near this appliance; (b) Never fill the cylinder beyond 80 percent full; (c) If the information in (a) and (b) is not followed exactly, a fire causing death or serious injury may occur.</p>		

	PROP 65 WARNING	
<p>Chemicals known to the State of California to cause cancer and birth defects or other reproductive harm are created by the combustion of propane, charcoal, or other wood products.</p>		



WARNING



- This outdoor cooking gas appliance shall be used only outdoors and shall not be used in a building, garage or any other enclosed area.
- This outdoor cooking gas appliance is not intended to be installed in or on boats. This appliance is not intended to be installed in or on recreational vehicles.
- Use your grill **OUTDOORS** in a well ventilated space away from dwellings or other buildings to prevent dangers associated with gas accumulation and toxic vapors. The grill should be situated at least 60 inches (152.4 cm) from buildings. Not adhering to these clearances will prevent proper ventilation and may increase the risk of a fire and/or property damage, which could also result in personal injury.
- Maintain a minimum clearance of 60 inches (152.4 cm) between all sides of grill, deck railings, walls or other combustible material. **DO NOT** use grill under any overhead combustible construction.
- **DO NOT** obstruct the flow of combustion/ventilation air.
- **DO NOT** leave the grill unattended while in use.
- **DO NOT** use while under the influence of drugs or alcohol.
- Keep the fuel supply hose away from heated surfaces.
- **DO NOT** put the grill in storage or move it after use. Allow the grill to be cool to the touch before moving/storing. Failure to do so could result in a fire causing property damage, personal injury or death.
- The appliance is for household use only. **DO NOT** use this grill for other than its intended purpose.
- Never use natural gas in a unit designed for liquid propane gas.
- Never use charcoal or wood briquettes in a gas grill. Flavoring chips must be contained in a metal smoking box to contain ash and prevent fires.
- A Leak Test must be conducted prior to each use.
- Keep a fire extinguisher on hand acceptable for use with gas products. Refer to your local authority to determine proper size and type.
- Grill is hot when in use. To avoid burns:
 - **DO NOT** attempt to move the grill.
 - Lock the wheels so the unit does not accidentally move.
 - Wear protective gloves or oven mitts.
 - **DO NOT** touch any hot grill surfaces.
 - **DO NOT** wear loose clothing or allow hair to come in contact with grill.
- Never close the side burner lid during operation.

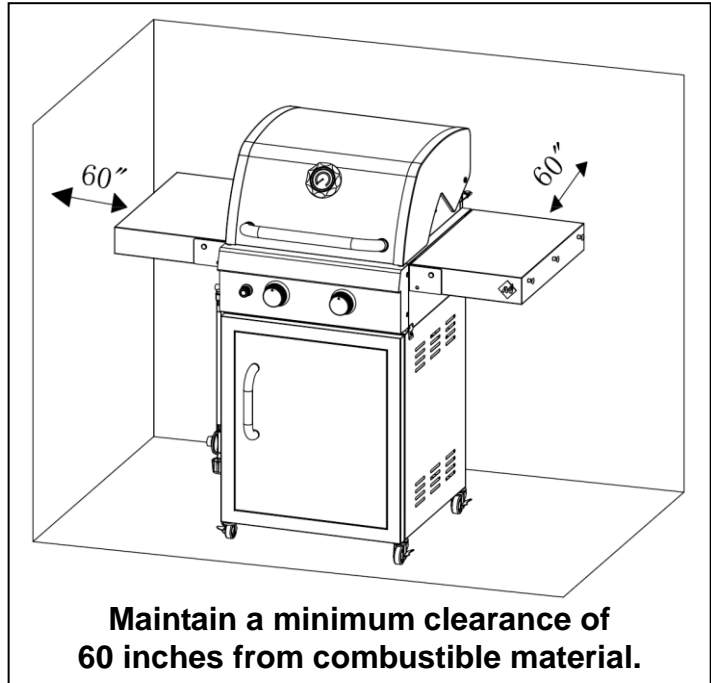

USE AND INSTALLATION OF LP GAS CYLINDER (PROPANE TANK)

BEFORE INSTALLING:

The installation must conform with local codes or, in the absence of local codes, with either the *National Fuel Gas Code, ANSI Z223.1/NFPA 54, Natural Gas and Propane Installation Code, CSA B149.1, or Propane Storage and Handling Code, B149.2, or the Standard for Recreational Vehicles, ANSI A 119.2/NFPA 1192, and CSA Z240 RV Series, Recreational Vehicle Code, as applicable.*

BEFORE EVERY USE:

Be sure to inspect the hose for leaks, cuts, wear, abrasion, or damage of any sort before using this appliance. If any damage is apparent, the hose must be replaced with a new hose specified by the manufacturer before further use.

LP GAS CYLINDER

The LP (liquid propane) cylinder specifically designed to be used with this unit **MUST** have a 20 lb. (9.1kg) capacity with a Type 1 cylinder valve and an overfilling protection device (OPD). Only use LP cylinders with this type of valve.

LP tank valve requirement:

- Purchase LP tanks only with these required measurements: 12” (30.5cm) (diameter) x 18” (45.7cm) (tall) with 20lb. (9kg) capacity maximum.
- Type 1 outlet compatible with regulator or appliance.
- Safety relief valve.
- UL-listed Overfill Protection Device (OPD). This OPD safety feature is identified by a unique triangular hand wheel. Use only tanks equipped with this type of valve.
- LP tank must be arranged for vapor withdrawal.

The LP cylinder must be constructed and marked in accordance with the Specifications for LP-Gas Cylinders of the U.S. Department of Transportation (D.O.T.) or the National Standard of Canada CAN/CSA – B339, Cylinder, Spheres and Tubes for Transportation of Dangerous Goods; and Commission of Dangerous Goods; and Commission, as applicable.

- The LP cylinder must include a collar to protect the cylinder valve.
- If the outdoor cooking gas appliance is not in use, the gas must be turned off at the supply cylinder(s).
- The LP cylinder must be stored outdoors out of the reach of children and **MUST NOT** be stored in a building, garage, shed, breezeway, or any other enclosed space.
- Storage of an outdoor cooking gas appliance indoors is permissible **ONLY** if the cylinder is disconnected and removed from the outdoor cooking gas appliance.
- The cylinder should **ALWAYS** be put in an upright position.

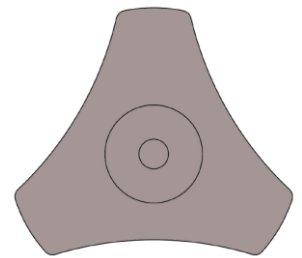

OPD Hand Wheel

LP Tank Valve

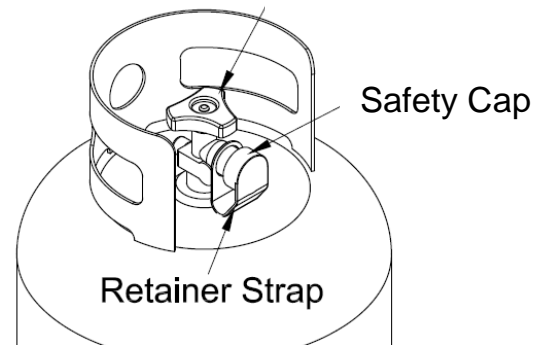

Safety Cap

Retainer Strap



DANGER



- DO NOT connect this grill to an existing #510 POL cylinder valve with Left hand threads. The Type 1 valve can be identified with the large external threads on the valve outlet.
- DO NOT connect to a propane cylinder exceeding its capacity.
- DO NOT connect to a cylinder that uses any other type of valve connection device.
- Never store a spare LP gas cylinder under or near your grill. This could cause pressure to be expelled through the vapor relief valve resulting in fire, explosion, or severe personal injury, including death.
- Keep the ventilation opening(s) of the LP gas cylinder enclosure free and clear from obstructions and debris.
- DO NOT insert any foreign objects into the valve outlet. Damage to the valve outlet could result. A damaged valve outlet can cause a leak, possibly resulting in explosions, fire, severe bodily harm, or death.



WARNING



FOR FILLING THE LP GAS CYLINDER

- Allow only qualified LP gas dealers to properly fill or repair your LP cylinder.
- DO NOT allow the cylinder to be filled beyond 80% capacity. Over-filled tanks can create a dangerous condition. Over-filled tanks can build up pressure and cause the relief valve to expel propane gas vapors. The vapor is combustible and if it comes in contact with a spark source or flame an explosion causing severe burns, bodily harm, or death could occur.
- Always use a safety cap when the grill is not connected to a cylinder.
- If you exchange a cylinder with a qualified exchange program, be sure the cylinder has a Type 1 valve and an over-fill prevention device (OPD).

INSTALLING GAS CYLINDER

1. Check that the cylinder valve is closed by turning the knob in clockwise.
2. Place the cylinder into cylinder holder and tighten the fixing bolt. Place cylinder such that the valve opening faces the left side table in such a way that the hose is not kinked/damaged.
3. Attach or detach the regulator to the LP gas cylinder only when the cylinder is placed on the cylinder holder.

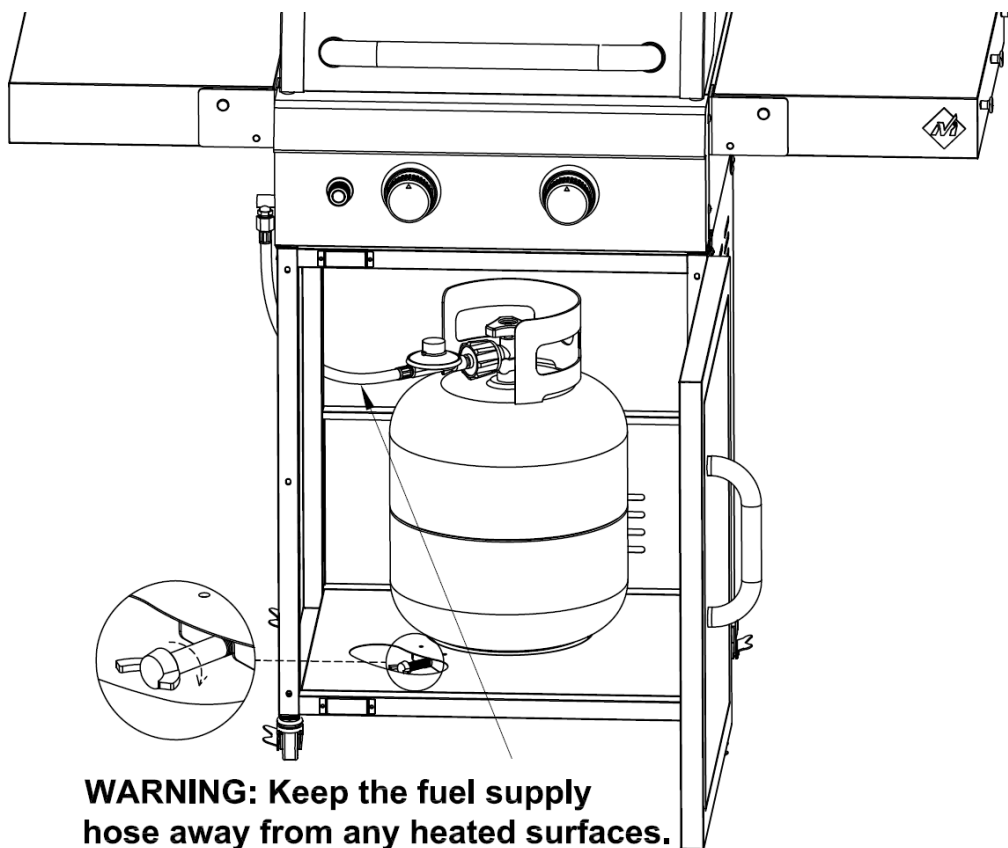

CONNECTION PROCEDURES

1. Make sure the tank valve is closed (turn valve clockwise until tight).
2. Check the tank valve to insure it has the proper external male threads.
3. Make sure all burner valves are turned **OFF**.
4. Inspect valve connections, port, and regulator assembly. Look for any damage or debris. Remove any debris. Inspect the hose for damage. Never attempt to use damaged or obstructed equipment. Contact your local LP gas dealer for repair.

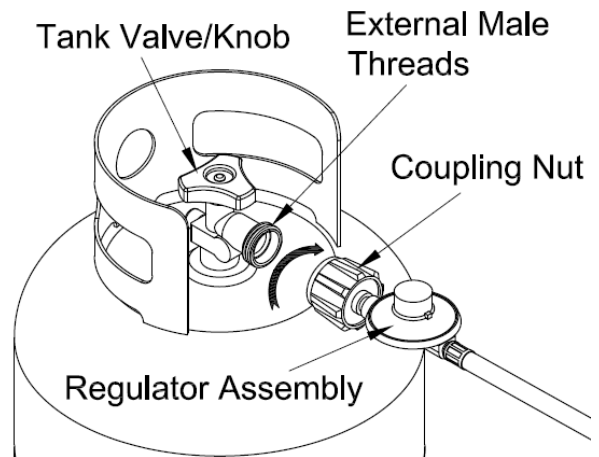

5. When connecting the regulator assembly to the valve, hand tighten the quick coupling nut clockwise to a complete stop. Do not use a wrench to tighten. Use of a wrench may damage the quick coupling nut and result in a hazardous condition.
6. Open the tank valve fully (counterclockwise). Use a soapy water solution to check all connections for leaks (a Leak Test) before attempting to light the grill (see P.24-25). If a leak is found, turn the tank valve off and do not use the grill until your LP gas dealer can make repairs.

TO DISCONNECT LP CYLINDER:

1. Turn the burner valves off.
2. Turn the tank valve off fully (turn clockwise to stop).
3. Detach the regulator assembly from the tank valve by turning the quick coupling nut counterclockwise.



CAUTION



- When installing LP cylinders, the pressure regulator and hose supplied by the manufacturer **MUST** be used with the appropriate cylinder. Replacement regulators and hoses need to be specified by the manufacturer of this appliance.
- Place the dust cap on the cylinder valve outlet whenever the cylinder is not in use. Only install the type of dust cap on the cylinder valve outlet that is provided with the cylinder. Other types of caps or plugs may result in leakage of propane.

PRODUCT DIAGRAM

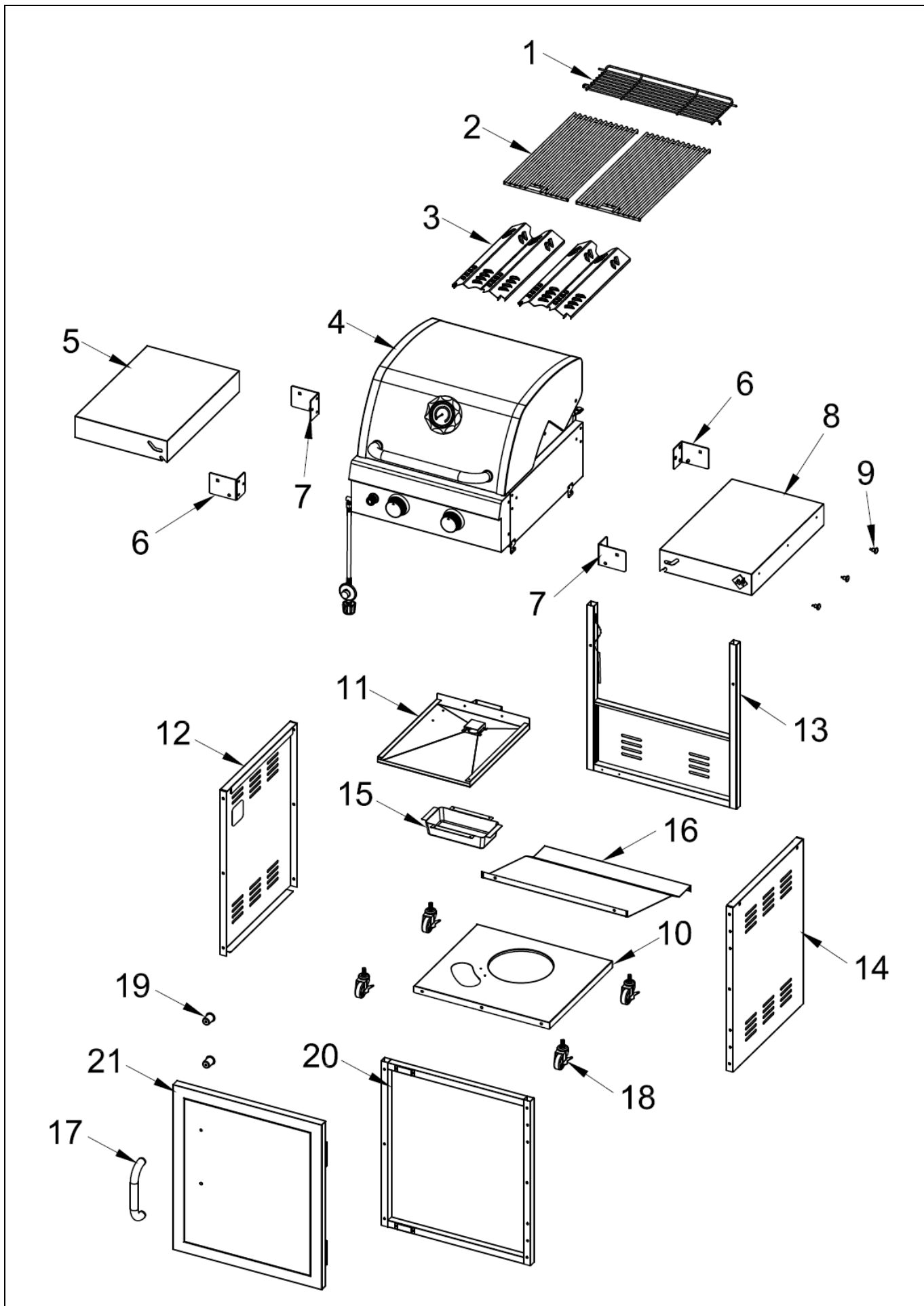

COMPONENT LIST

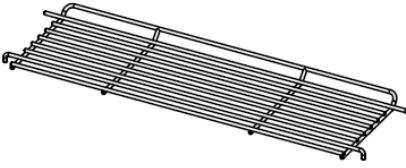
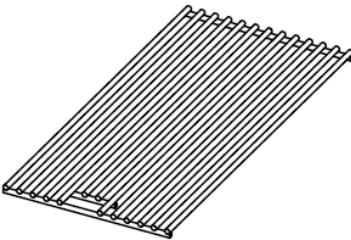
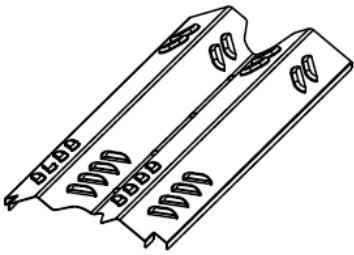
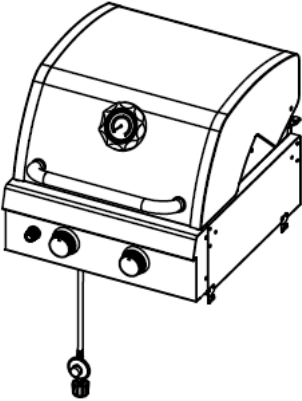
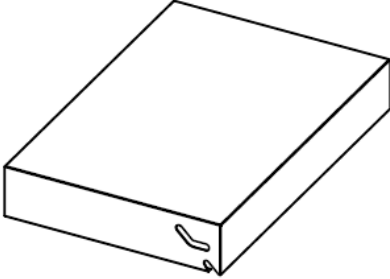
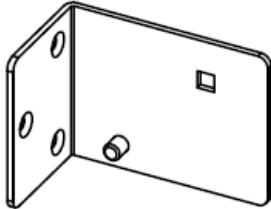
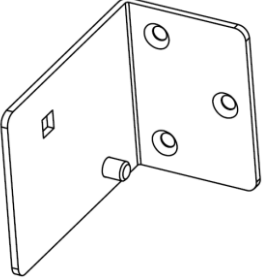
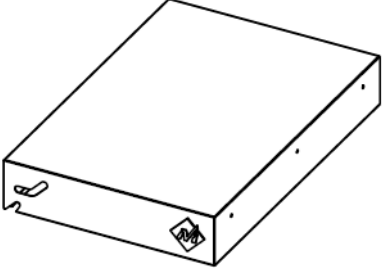
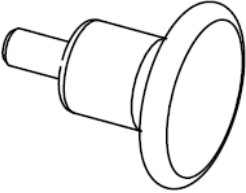
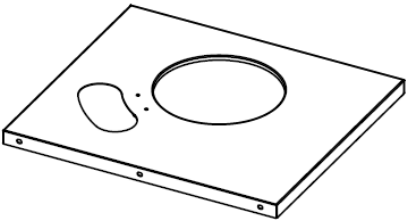
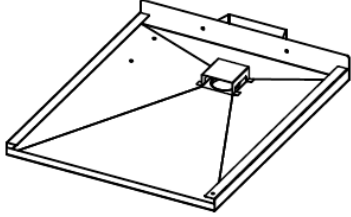
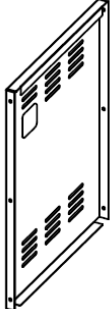
<p>1. Warming Rack</p>  <p>Qty: 1pc</p>	<p>2. Cooking Grate</p>  <p>Qty: 2pcs</p>	<p>3. Flame Tamer</p>  <p>Qty: 2pcs</p>
<p>4. Grill Body Assembly</p>  <p>Qty: 1pc</p>	<p>5. Left Side Table</p>  <p>Qty: 1pc</p>	<p>6. Right Side Table Bracket</p>  <p>Qty: 2pcs</p>
<p>7. Left Side Table Bracket</p>  <p>Qty: 2pcs</p>	<p>8. Right Side Table</p>  <p>Qty: 1pc</p>	<p>9. Hook</p>  <p>Qty: 3pcs</p>
<p>10. Cart Base Assembly</p>  <p>Qty: 1pc</p>	<p>11. Drip Tray</p>  <p>Qty: 1pc</p>	<p>12. Left Cart Panel Assembly</p>  <p>Qty: 1pc</p>

13. Rear Cart Panel Assembly

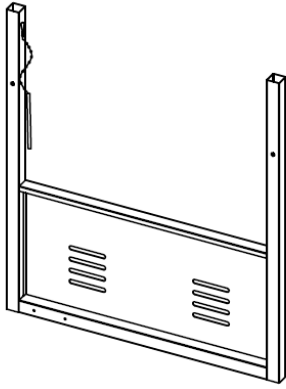

Qty: 1pc

14. Right Cart Panel

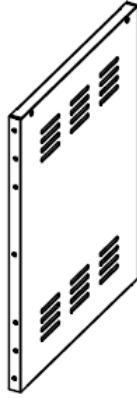

Qty: 1pc

15. Grease Cup

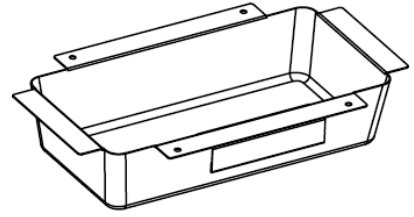

Qty: 1pc

16. Tank Heat Shield

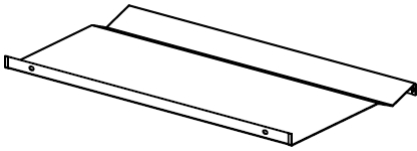

Qty: 1pc

17. Cart Door Handle



Qty: 1pc

18. Locking Caster

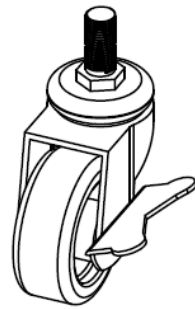

Qty: 4pcs

19. Plastic Insert



Qty: 2pcs

20. Front Cart Frame

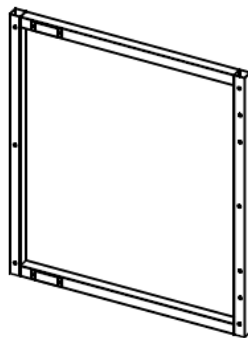





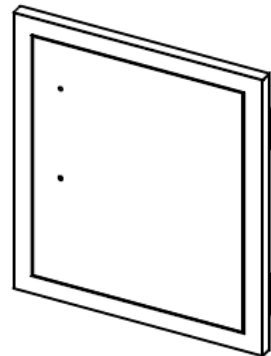



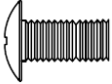

Qty: 1pc

21. Cart Door

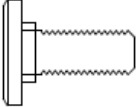

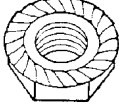
Qty: 1pc

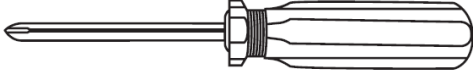
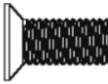
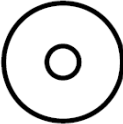
HARDWARE LIST

Item No.	Item name	Diagram	Qty
A	M6x12mm Bolt		28
B	M4x10mm Countersink Head Bolt		5
C	Hex Nut Wrench		1
D	M4 Nut		3
E	Table Pin		4
F	Rotary sleeve		4
G	M6 Serrated Flange Nut		4
H	LR6/AA Battery		1
I	Phillips Head Screwdriver		1
J	M6x16mm Countersink Head Bolt		12
K	Ø18 Washer		1
L	Ø12 Washer		3
M	Tank Fixing Bolt		1

Replacement Part List (I)

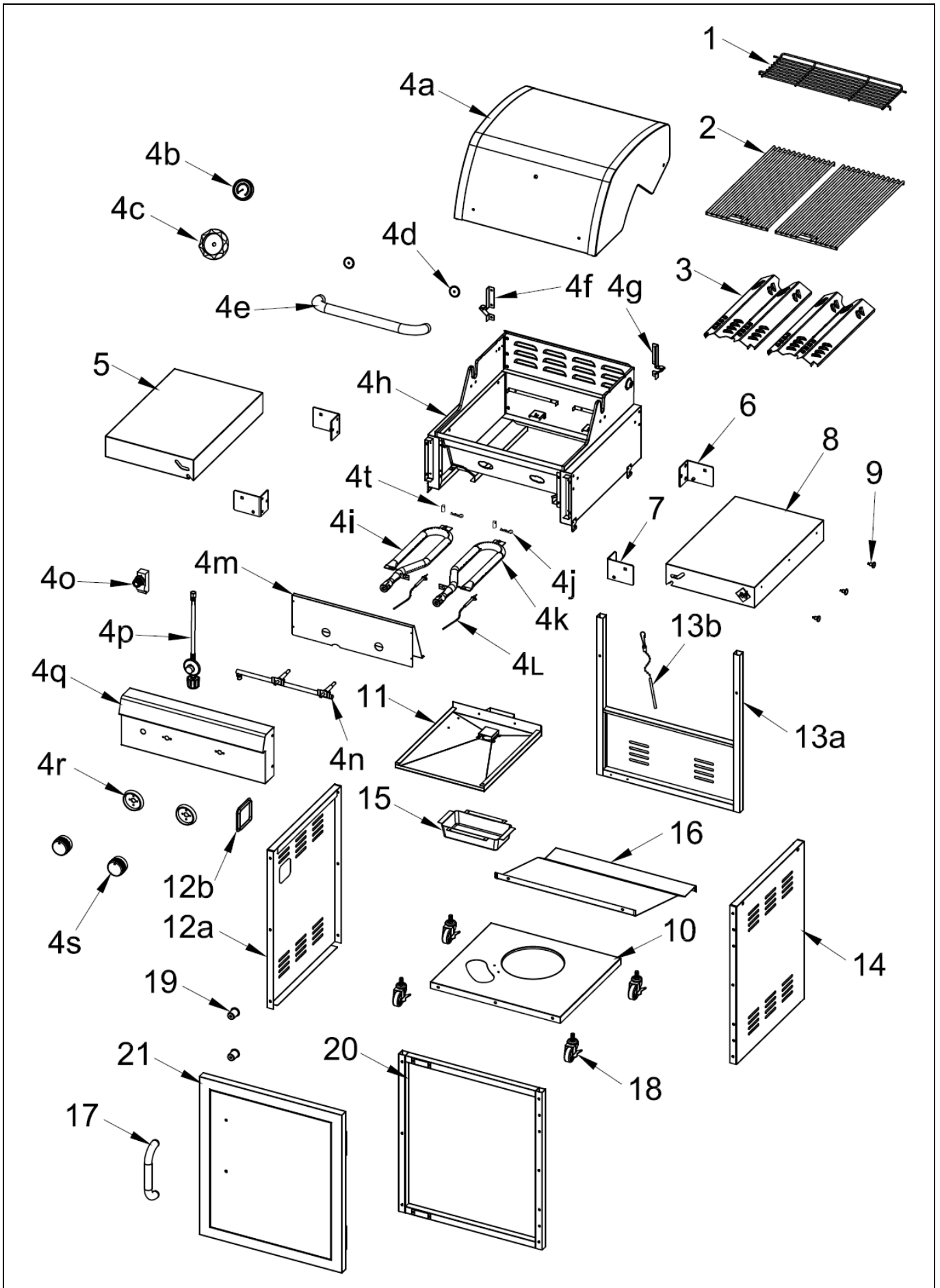

Replacement Part List (II)

Part Number	Part Name	Part Number	Part Name
1	Warming Rack	2	Cooking Grate
3	Flame Tamer	4	Grill Body Assembly
4a	Grill Body – Lid	4b	Grill Body – Thermometer
4c	Grill Body – Thermometer Bezel	4d	Grill Body – Lid Handle Bezel
4e	Grill Body – Lid Handle	4f	Grill Body – Lid Support Left Bracket
4g	Grill Body – Lid Support Right Bracket	4h	Grill Body – Fire Box
4i	Grill Body – Left Burner	4j	Grill Body – Cotter Pin
4k	Grill Body – Right Burner	4L	Grill Body – Ignition Electrode & Wire
4m	Grill Body – Fire Box Front Heat Shield	4n	Grill Body – Valve & Manifold Assembly
4o	Grill Body – Igniter	4p	Grill Body – Regulator Assembly
4q	Grill Body – Control Panel	4r	Grill Body – Knob Bezel
4s	Grill Body – Control Knob	4t	Grill Body – Burner Fixing Pin
5	Left Side Table	6	Right Side Table Bracket
7	Left Side Table Bracket	8	Right Side Table
9	Hook	10	Cart Base
11	Drip Tray	12	Left Cart Panel Assembly
12a	Left Cart Panel	12b	Plastic Ring
13	Rear Cart Panel Assembly	13a	Rear Cart Panel
13b	Match Holder	14	Right Cart Panel
15	Grease Cup	16	Tank Heat Shield
17	Cart Door Handle	18	Locking Caster
19	Plastic Insert	20	Front Cart Frame
21	Cart Door		

Symbol: The following symbols will be shown in each procedure for indication of tightening the bolt and nut if necessary.

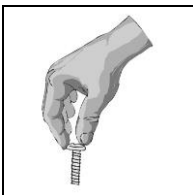

Hand Tighten only at this time

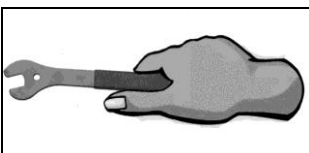

Tighten with tools at this time

ASSEMBLY PROCEDURES

Step 1. Install the **Tank Fixing Bolt (M)** into the **Cart Base (10)** as shown. Attach the **Ø18 Washer (K)** to the tank fixing bolt with a **Countersink Head M4 Bolts (B)**.

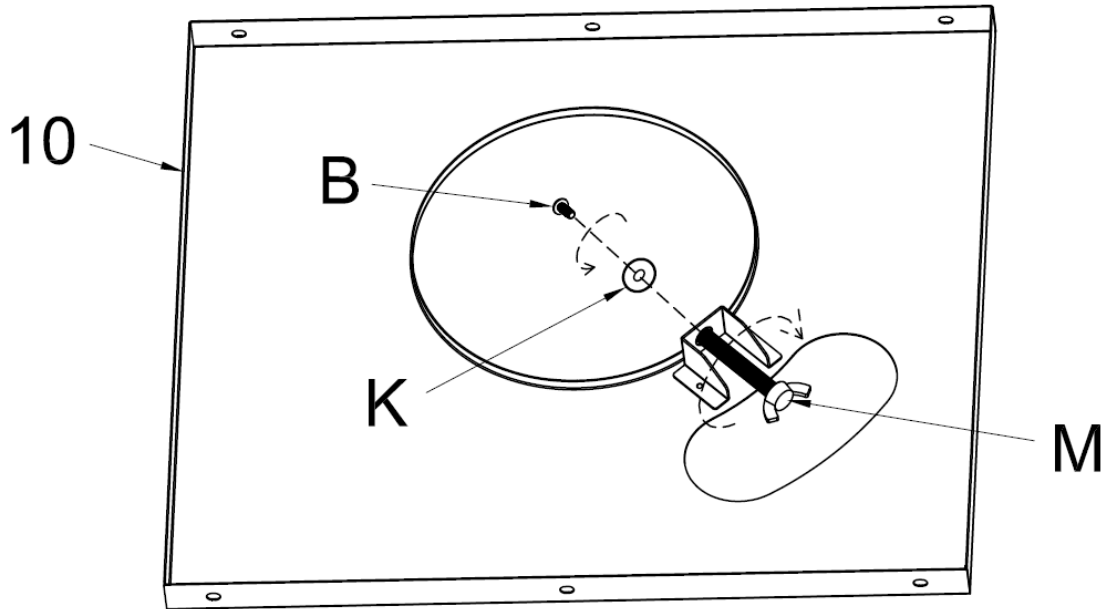

Step 2. Attach the cart base to the **Rear Cart Panel Assembly (13)** using 3 pcs **M6x12 Bolts (A)**. Do not fully tighten the bolts.

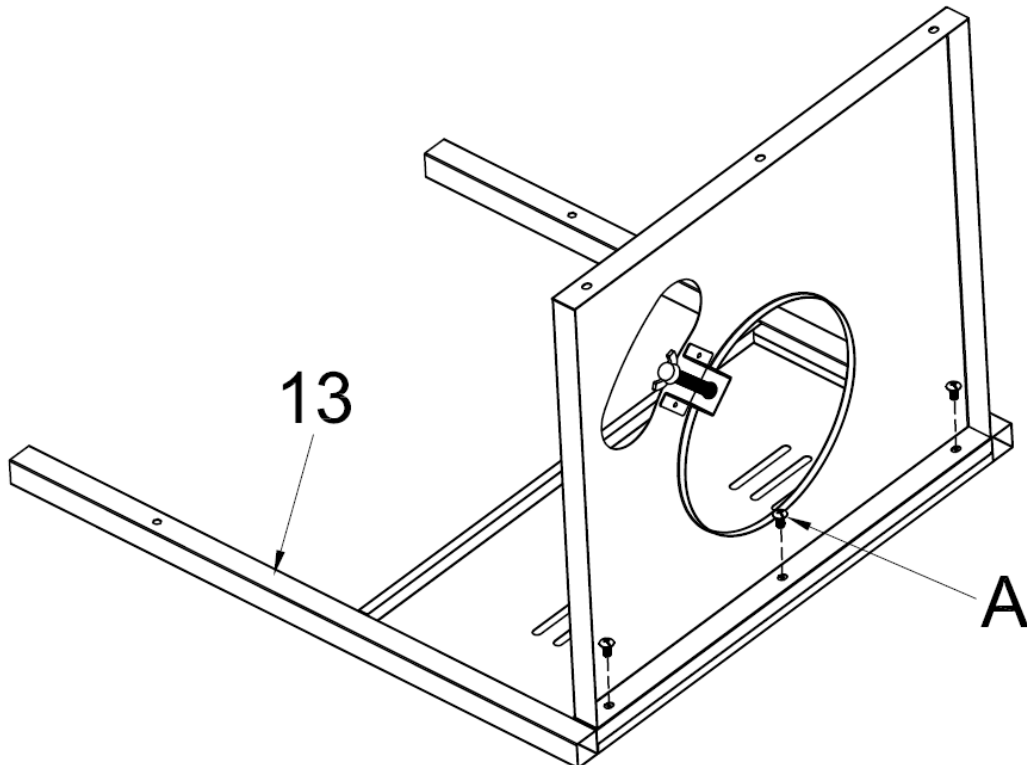
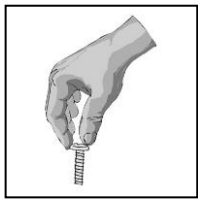

Step 3. Attach the **Front Cart Frame (20)** to the cart base using 3 pcs **M6x12 Bolts (A)**. Do not fully tighten the bolts.

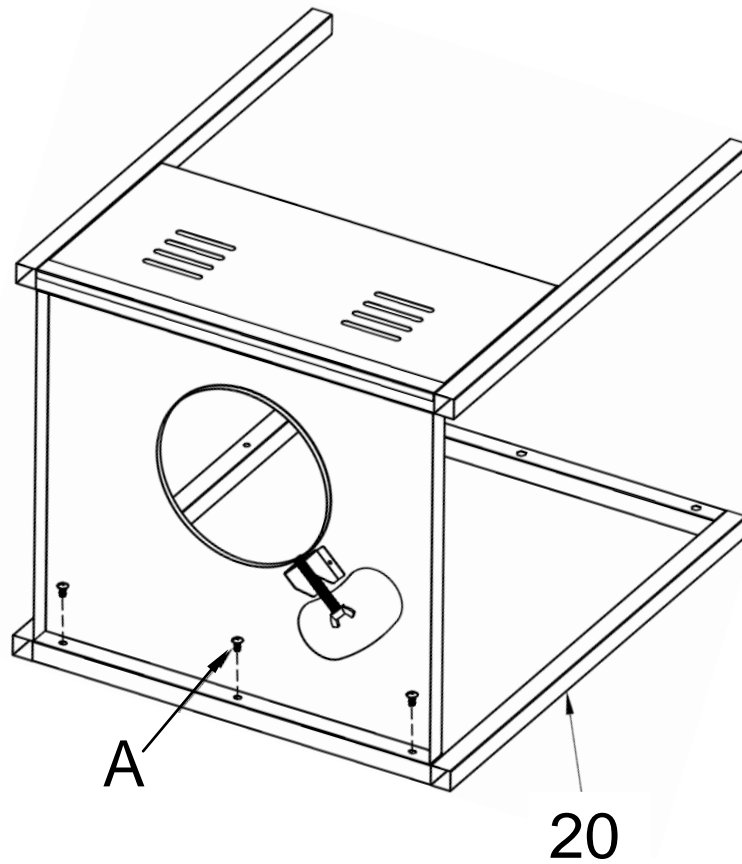
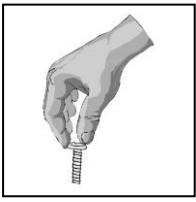

Step 4. Attach the **Tank Heat Shield (16)** to the cart assembly using 4 pcs **M6x12 Bolts (A)**. Do not fully tighten the bolts.

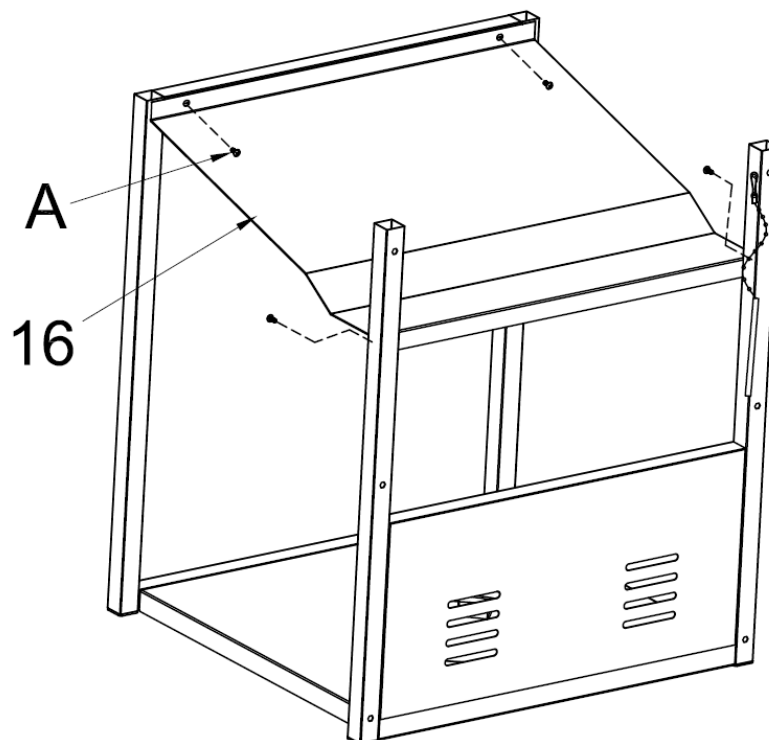
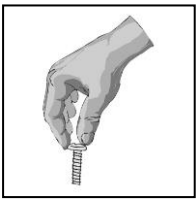

Step 5. Attach the **Right Cart Panel (14)** and **Left Cart Panel Assembly (12)** to the cart assembly using 12 pcs **M6x12 Bolts (A)**. Fully tighten all the bolts in the cart assembly.

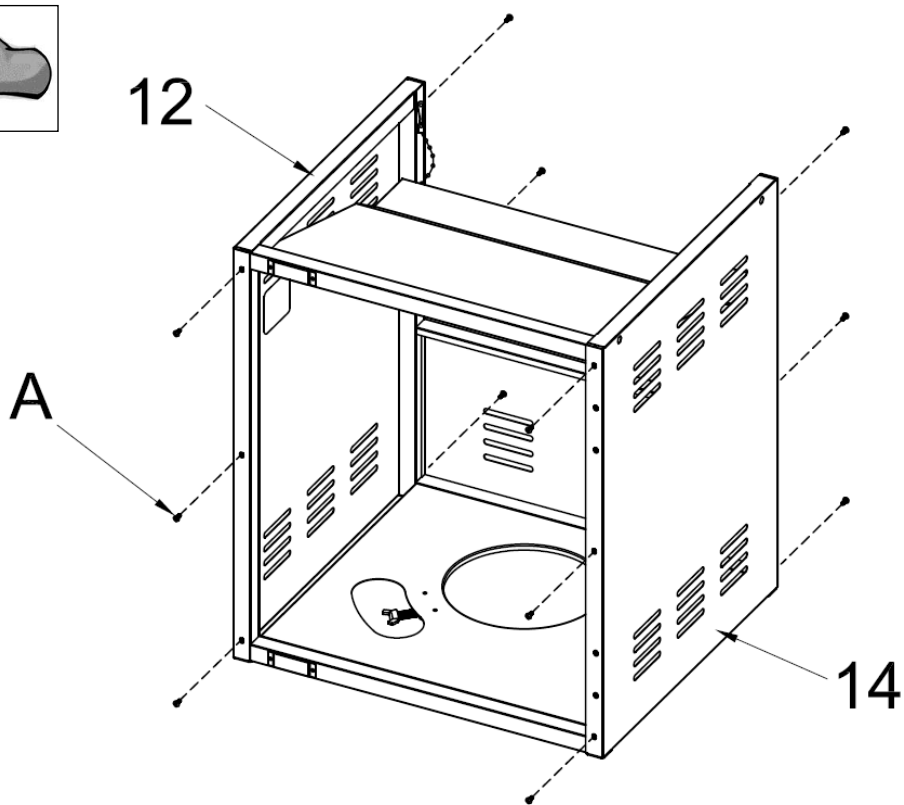
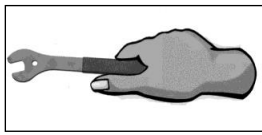

Step 6. Install the **Locking Casters (18)** into the threaded holes on the bottom of the cart assembly. Use the **Hex Nut Wrench (C)** to tighten the caster by turning in clockwise until it is fully secured.

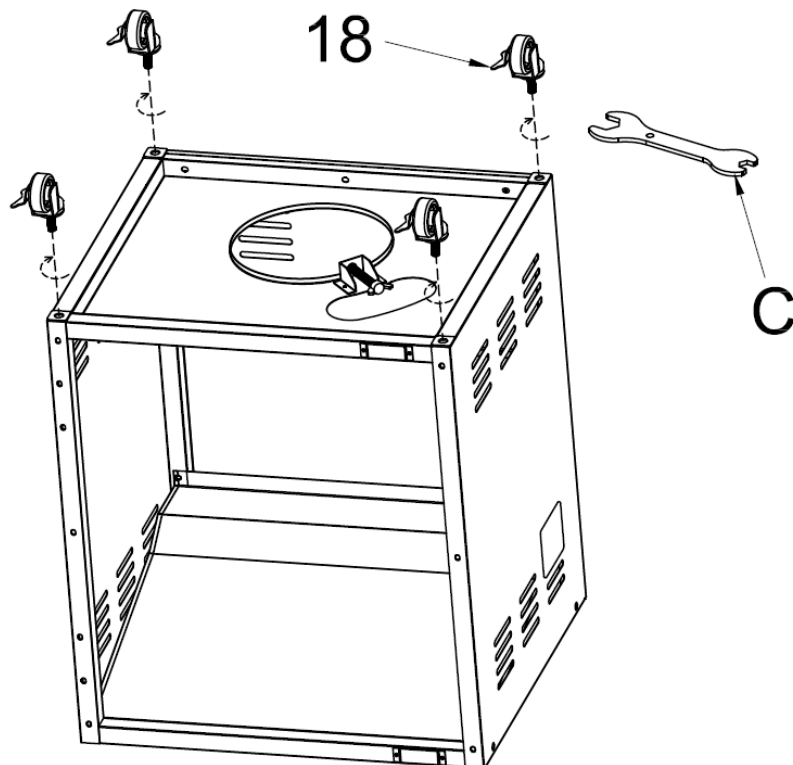
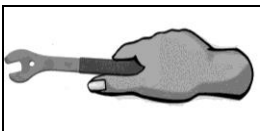

Step 7. Lock all 4 pcs casters to prevent the unit from moving. Attach the **Cart Door (21)** to the cart assembly using 4 pcs **Countersink Head M4 Bolts (B)**. Do not tighten the bolts until all the holes on the hinges are aligned and match with the cart assembly. Then fully tighten the bolts.

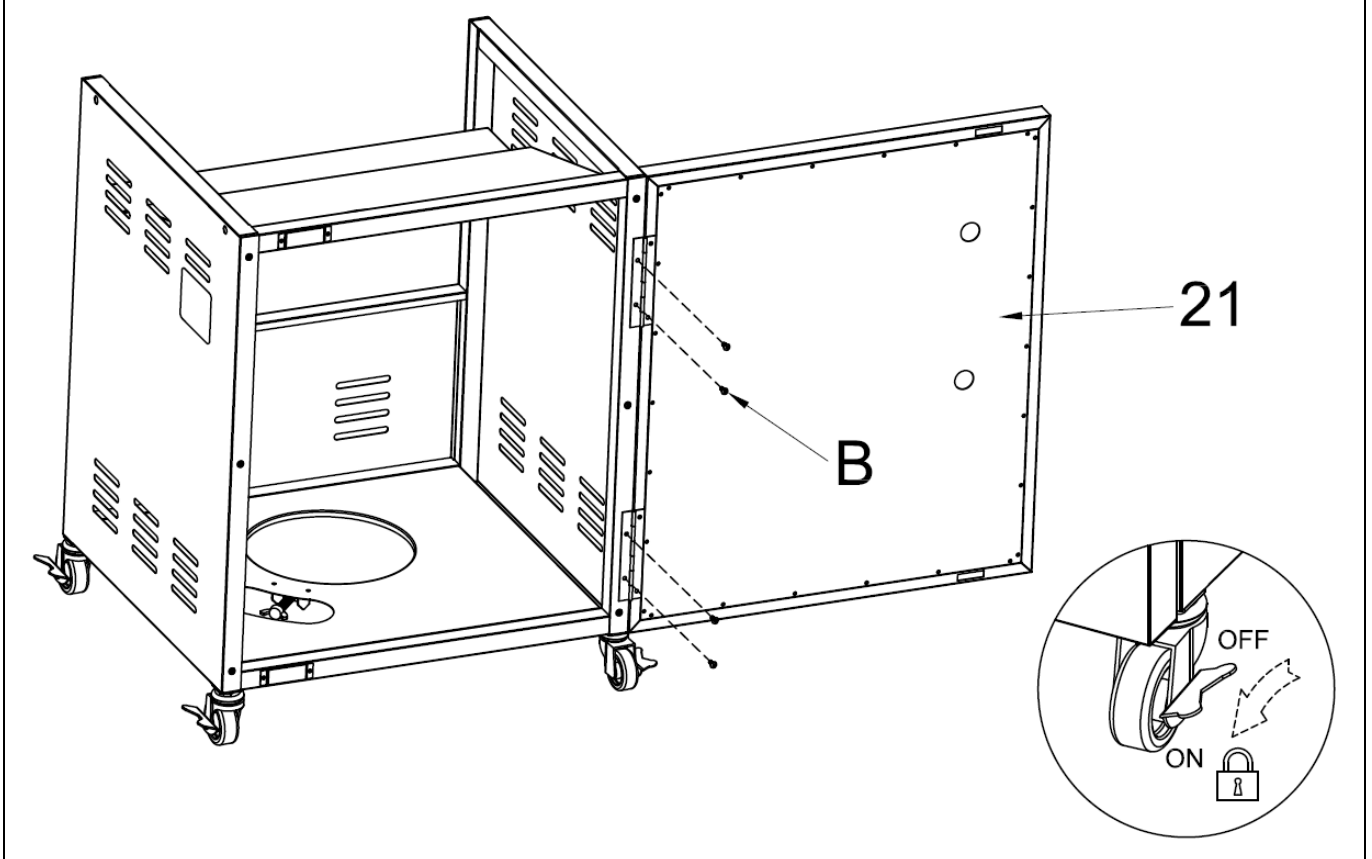

Step 8. Attach the **Cart Door Handle (17)** and the **Plastic Insert (19)** to the cart assembly using 2 pcs **M6x12 bolts (A)**.

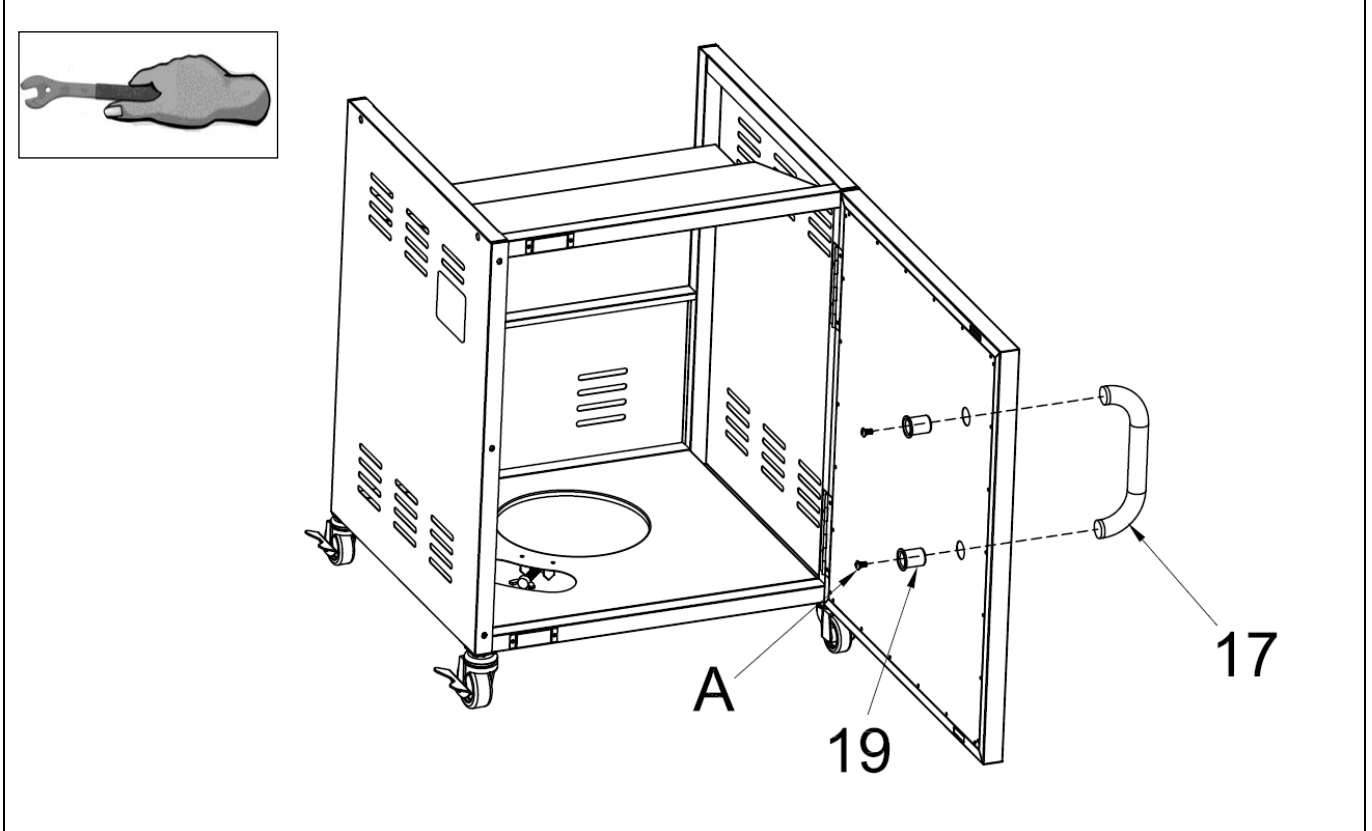

Step 9. This step needs two people to complete! Keep all 4 pcs caster locked. Install 4 pcs of **M6x12mm bolts (A)** on the cart assembly and adjust to 3/16" clearance as shown. Put the **Grill Body assembly (4)** carefully on the top of cart assembly. Position the part in place then fully tighten the bolts. Be careful to support the grill body and cart assembly during this step.

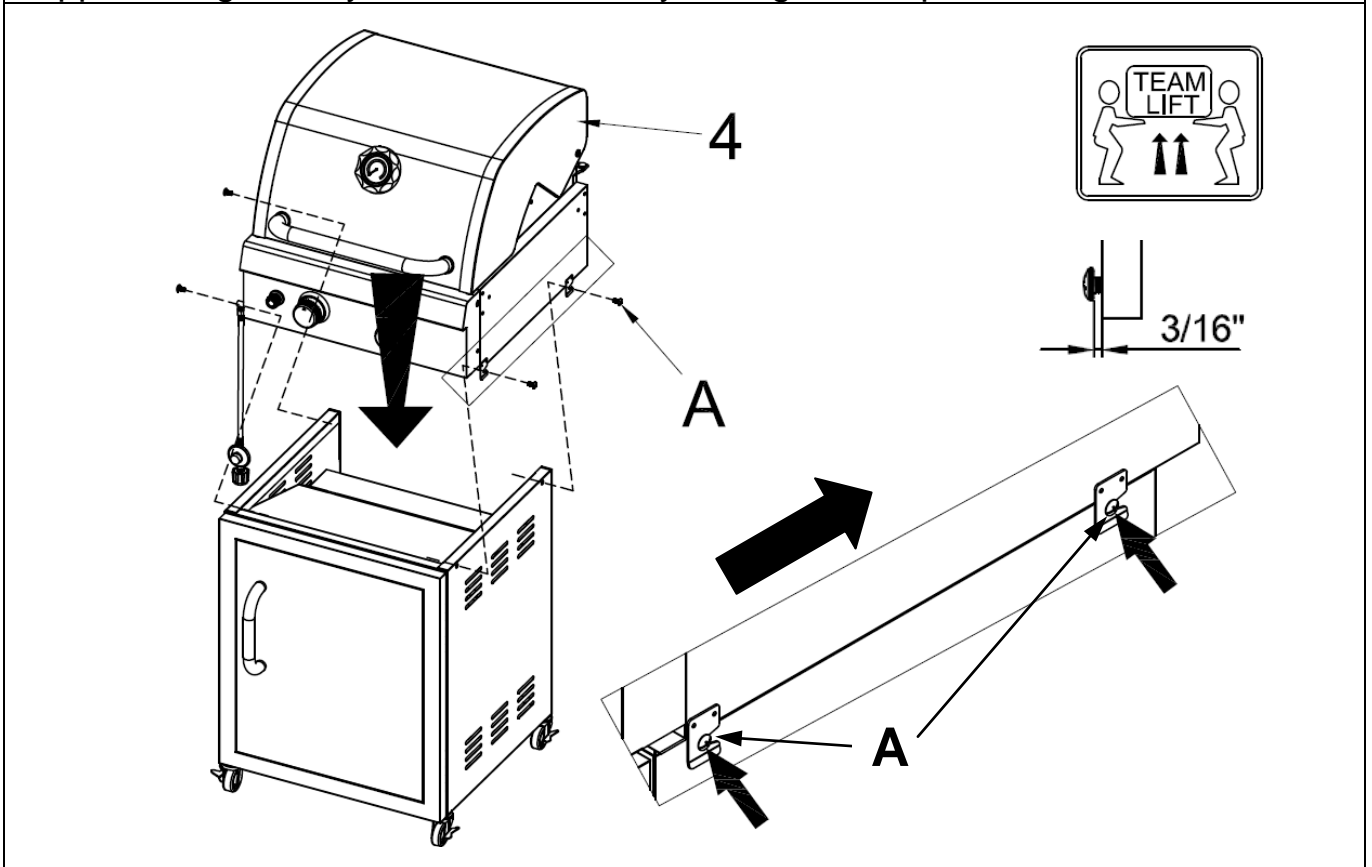

Step 10. Attach the **Right Side Table Bracket (6)** and **Left Side Table Bracket (7)** to the grill body assembly using 12 pcs **Countersink Head Bolt M6 bolts (J)**.

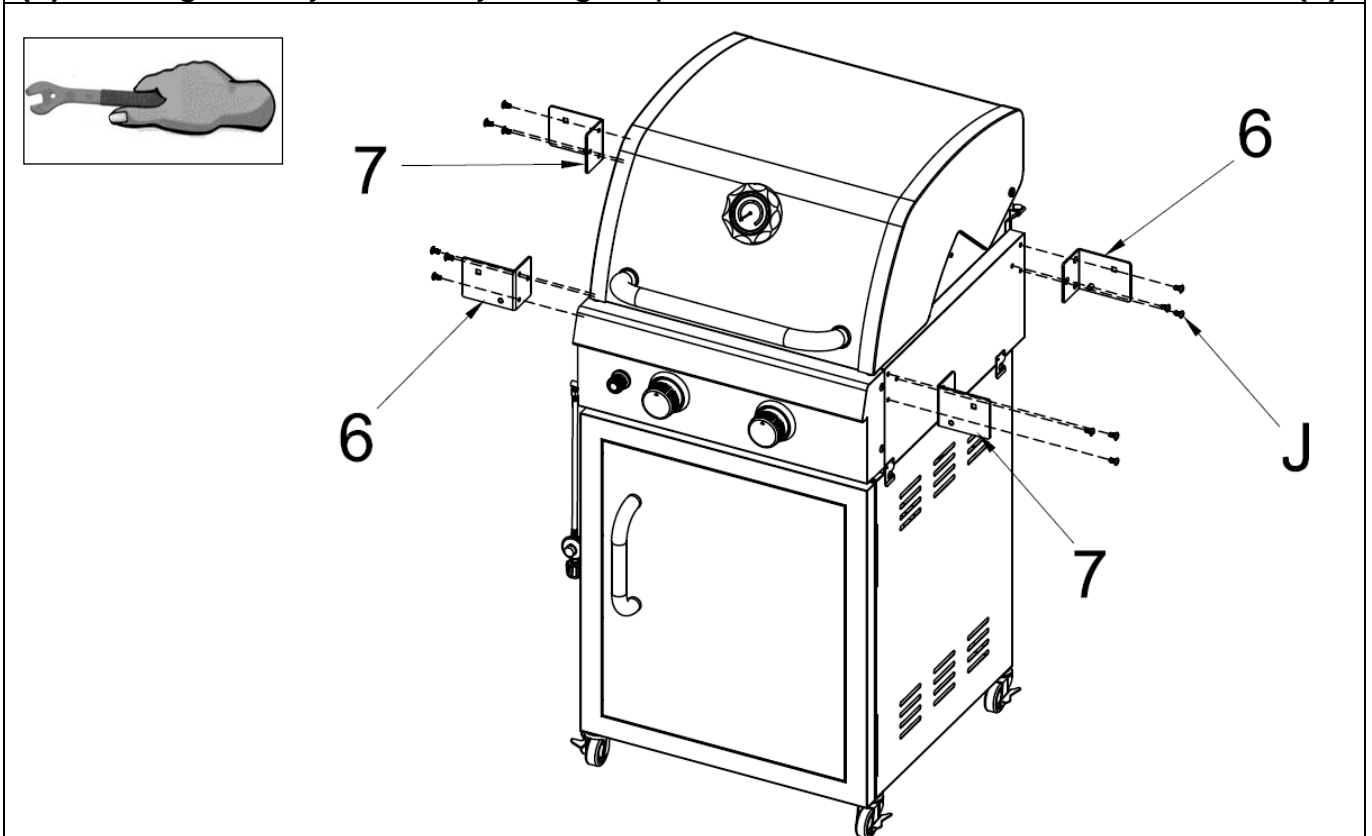

Step 11. Attach the **Hook (9)** to the **Right Side Table (8)** using 3 pcs **Ø12 Washer (L)** and 3 pcs **M4 nuts (D)**.

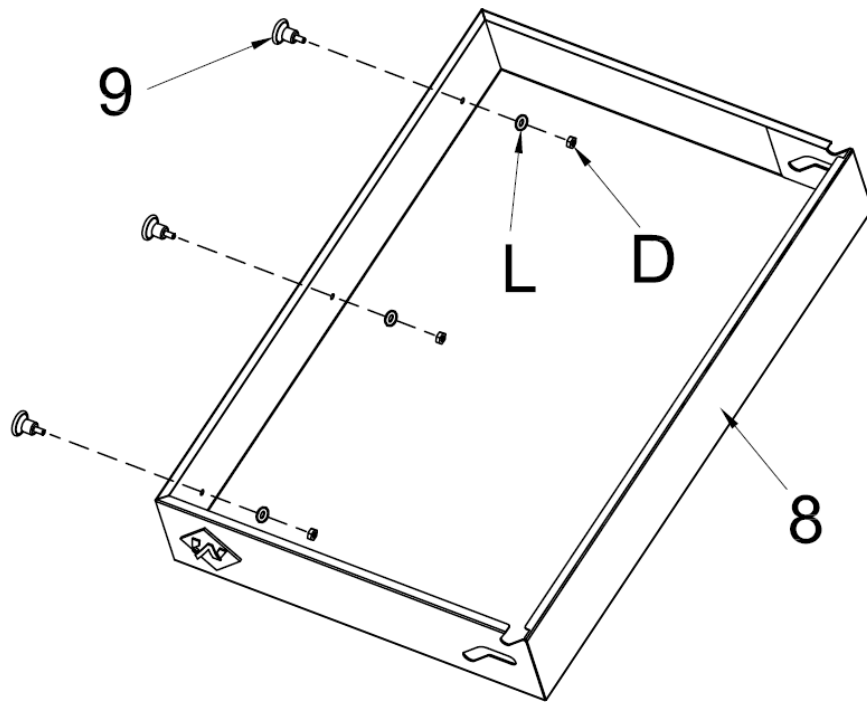
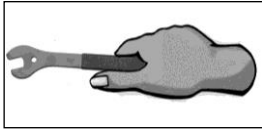

Step 12: Attach the right side table assembly to the side table brackets and insert 2 pcs **Table pin (E)** into the brackets and side table to hold them up. Then fold the table upwards and using 2 pcs **Rotary sleeve (F)** and **M6 Serrated Flange Nut (G)** as shown for installation. Use the **Hex Nut Wrench (C)** to tighten the nuts.

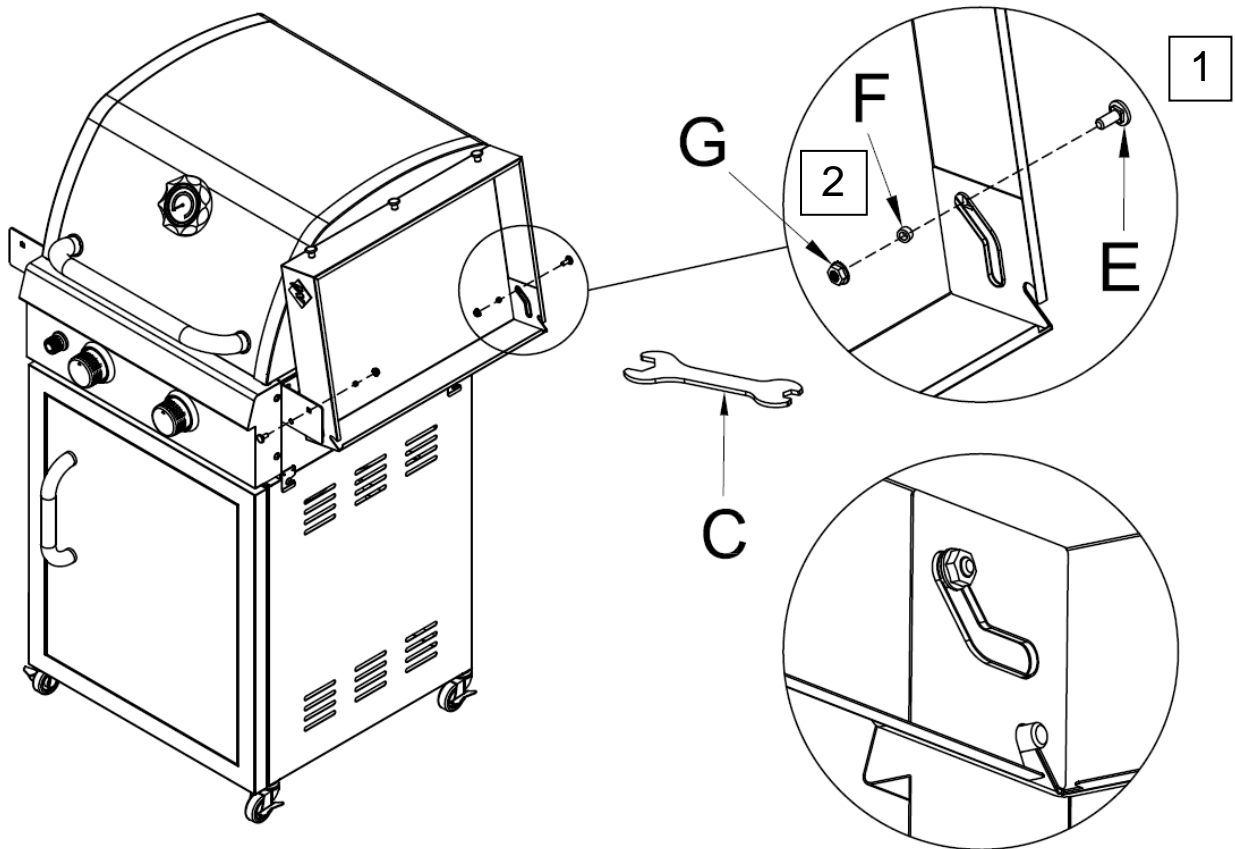

Step 13: Attach the **Left Side Table (5)** to the side table brackets and insert 2 pcs **Table pin (E)** into the brackets and side table to hold them up. Then fold the table upwards then using 2 pcs **Rotary sleeve (F)** and **M6 Serrated Flange Nut (G)** as shown for installation. Use the **Hex Nut Wrench (C)** to tighten the nuts.

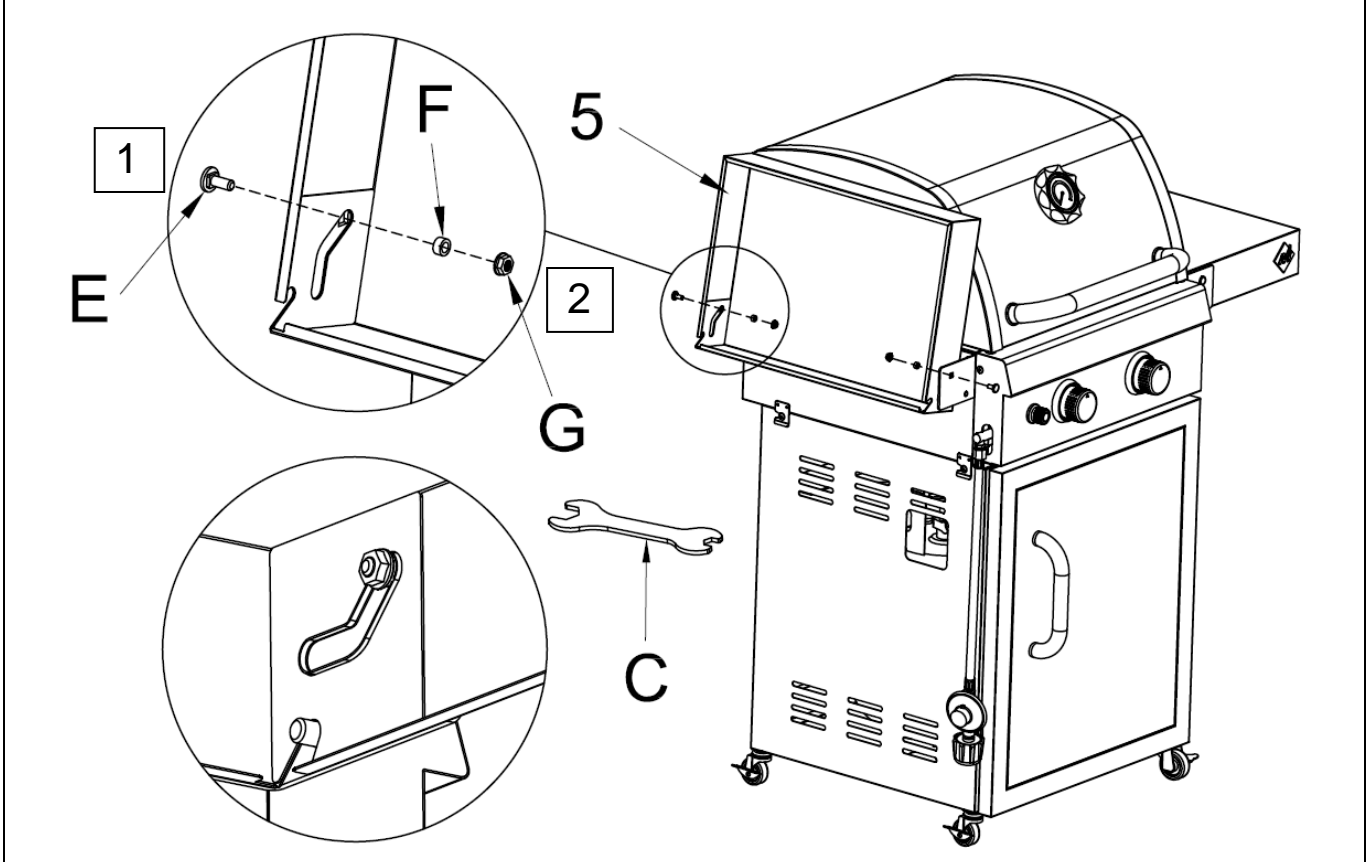

Step 14: Slide the **Drip Tray (11)** into the holding bracket at the bottom of the fire box. Slide the **Grease Cup (15)** into the holding bracket at the bottom of the drip tray. Be sure the handle is facing outward.

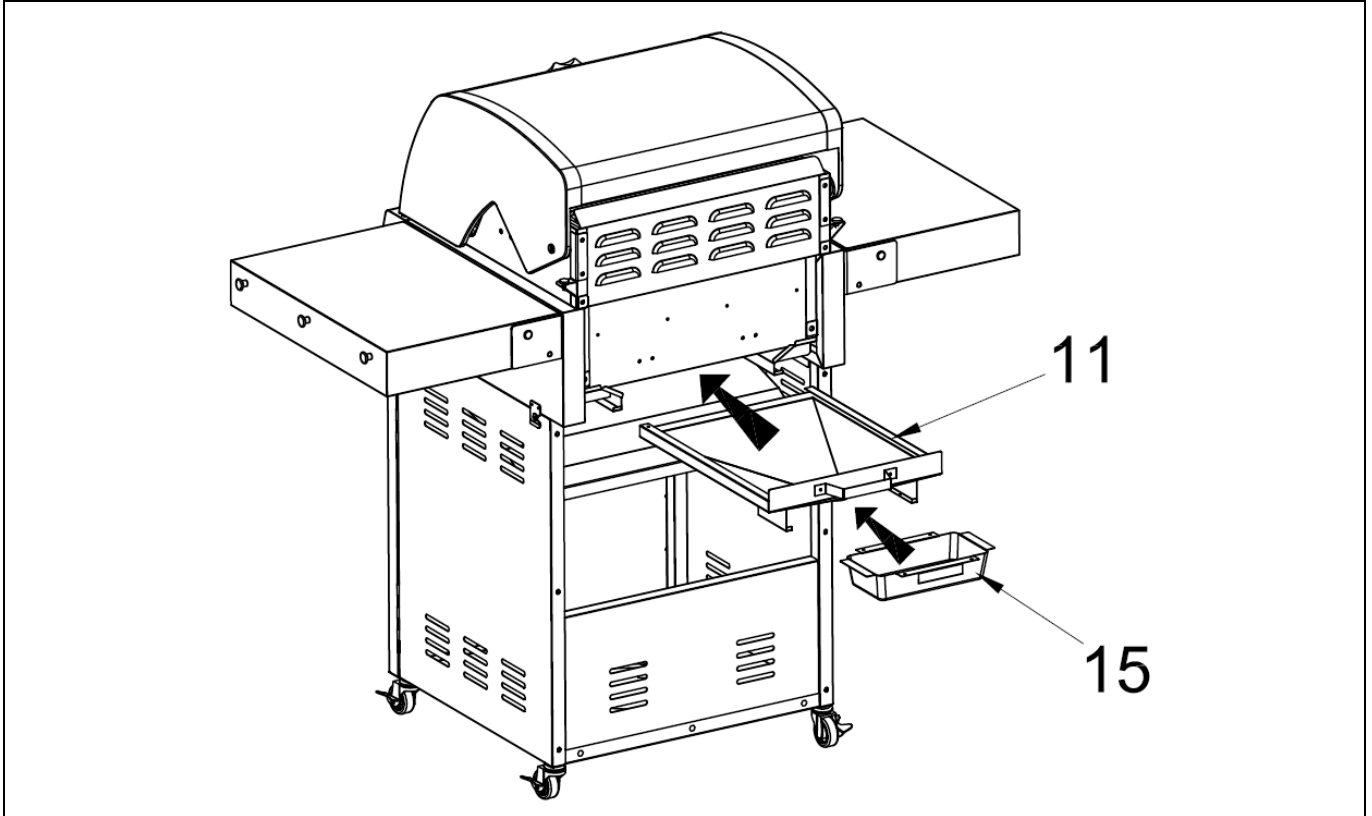

Step 15: Place the Flame Tamer (3) on the grill as shown.

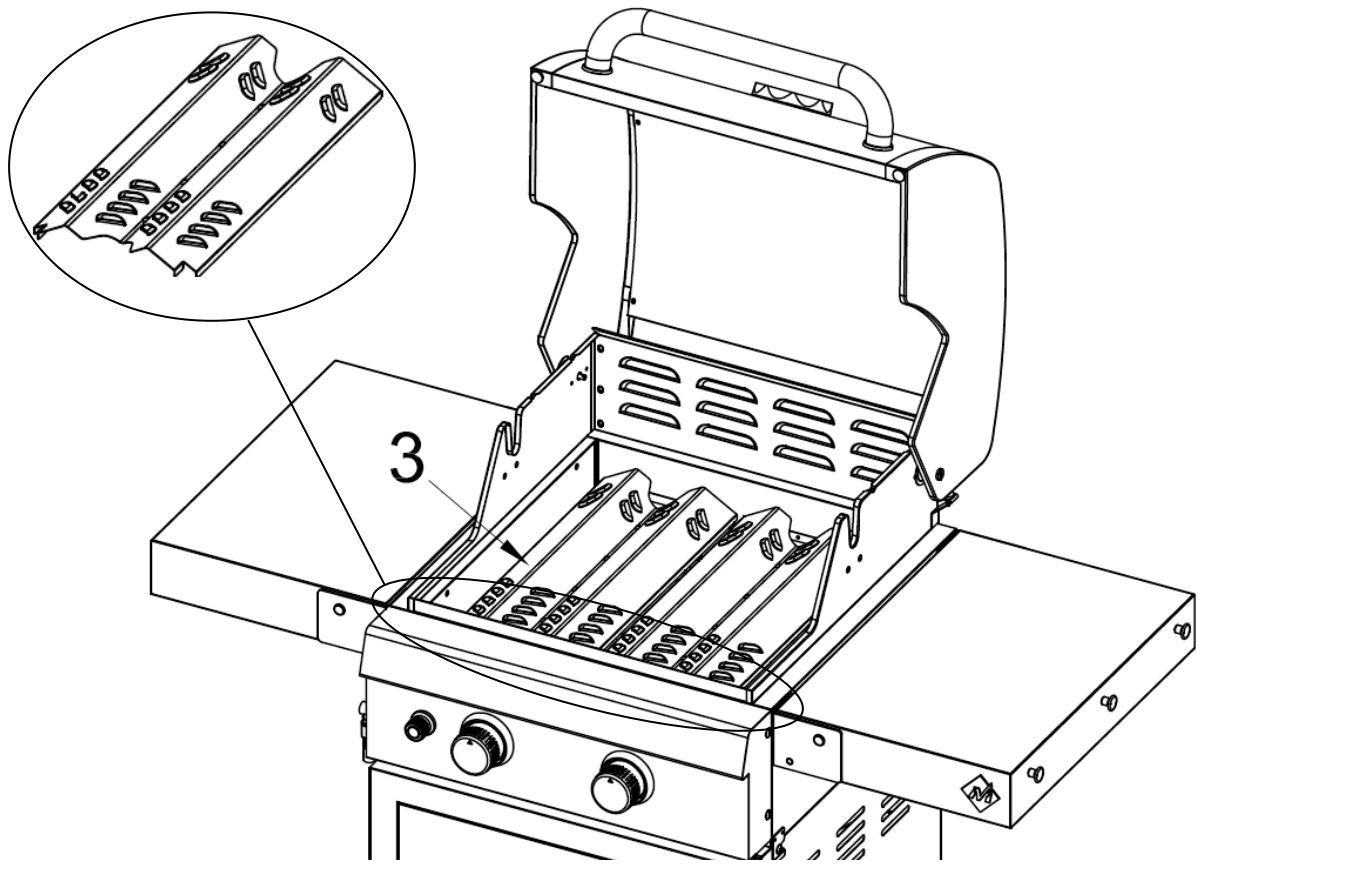

Step 16: Place the Cooking Grates (2) on the grill as shown.

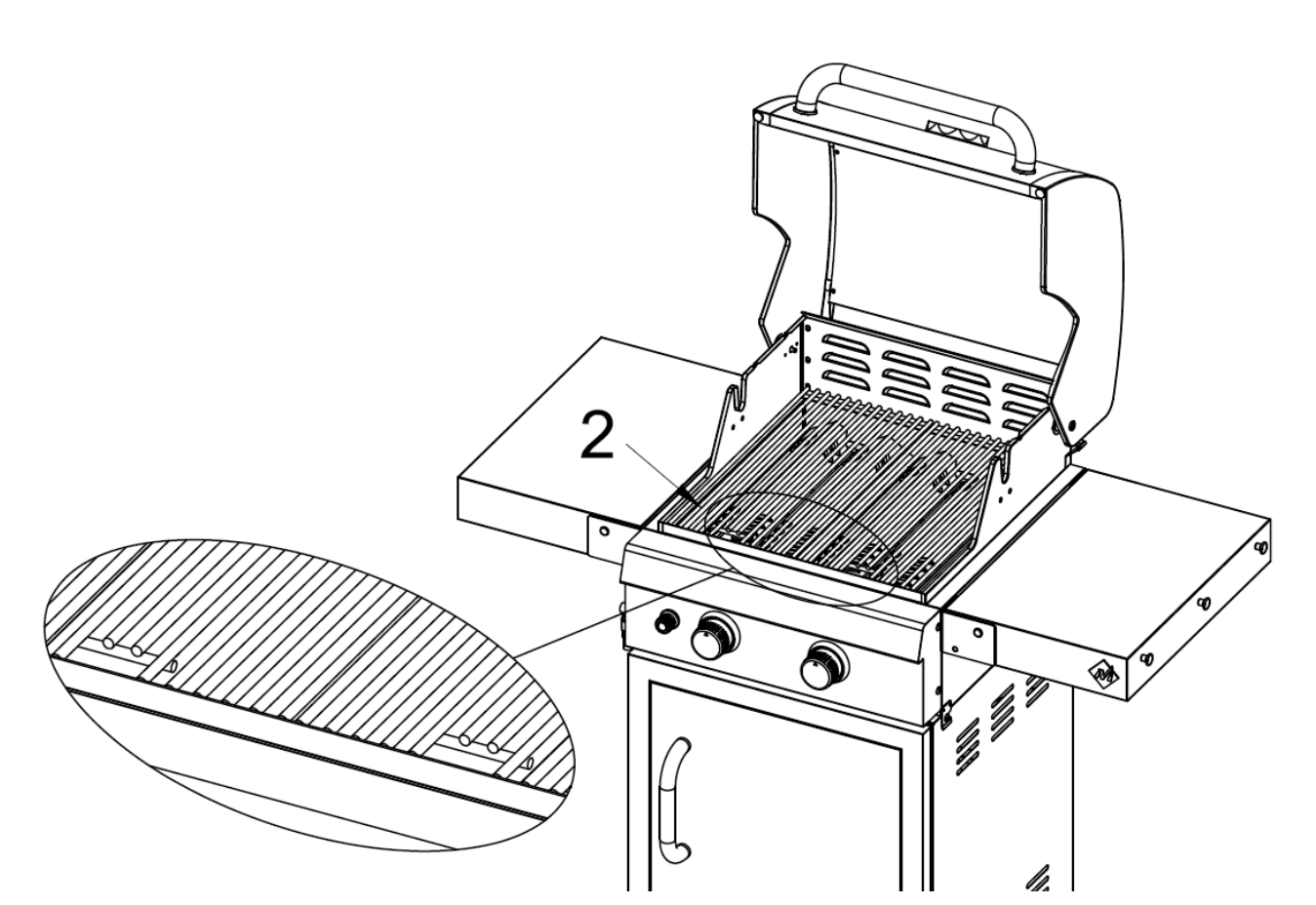

Step 17: Place the **Warming Rack (1)** on the grill as shown.

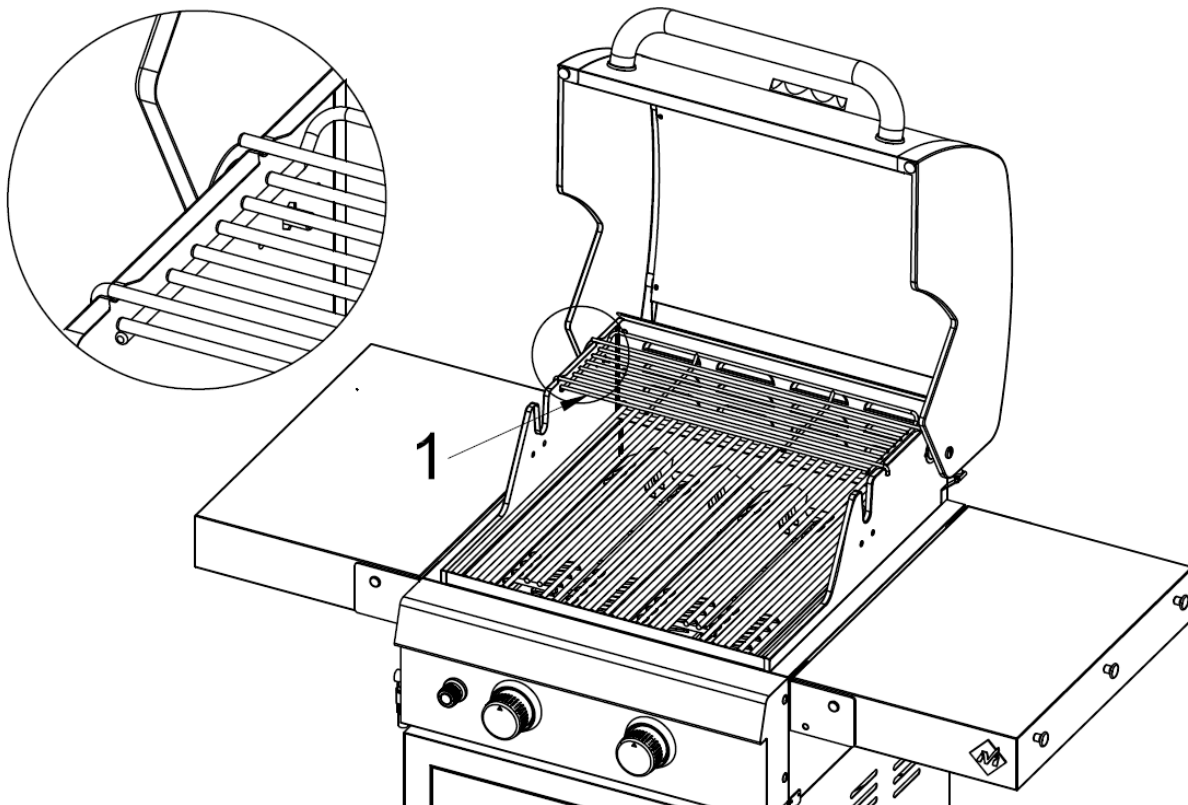

Step 18. Install a **LR6/AA Battery (H)** into the igniter. Please ensure the polarity of the battery positioned correctly.

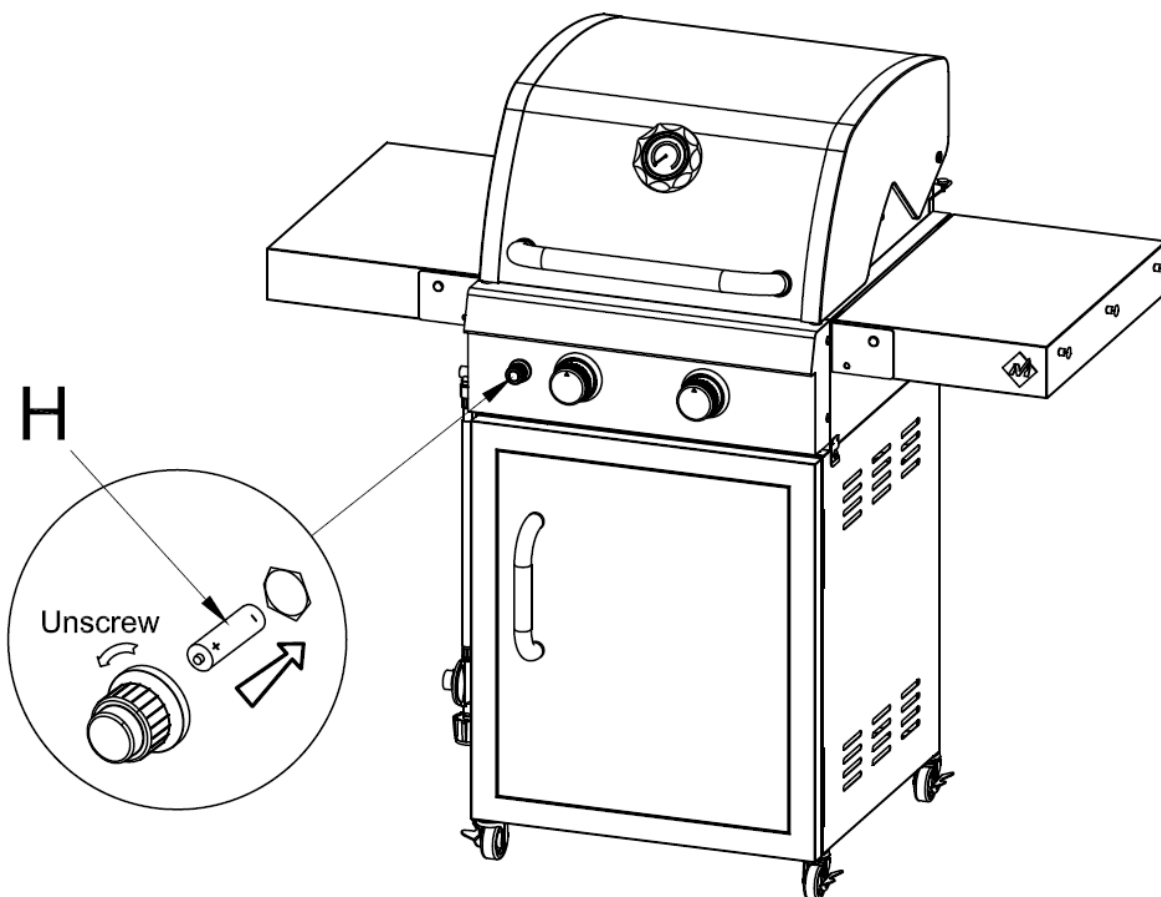

Step 19. Your unit is fully assembled! Make sure to read and follow the Instruction Manual before using this appliance.

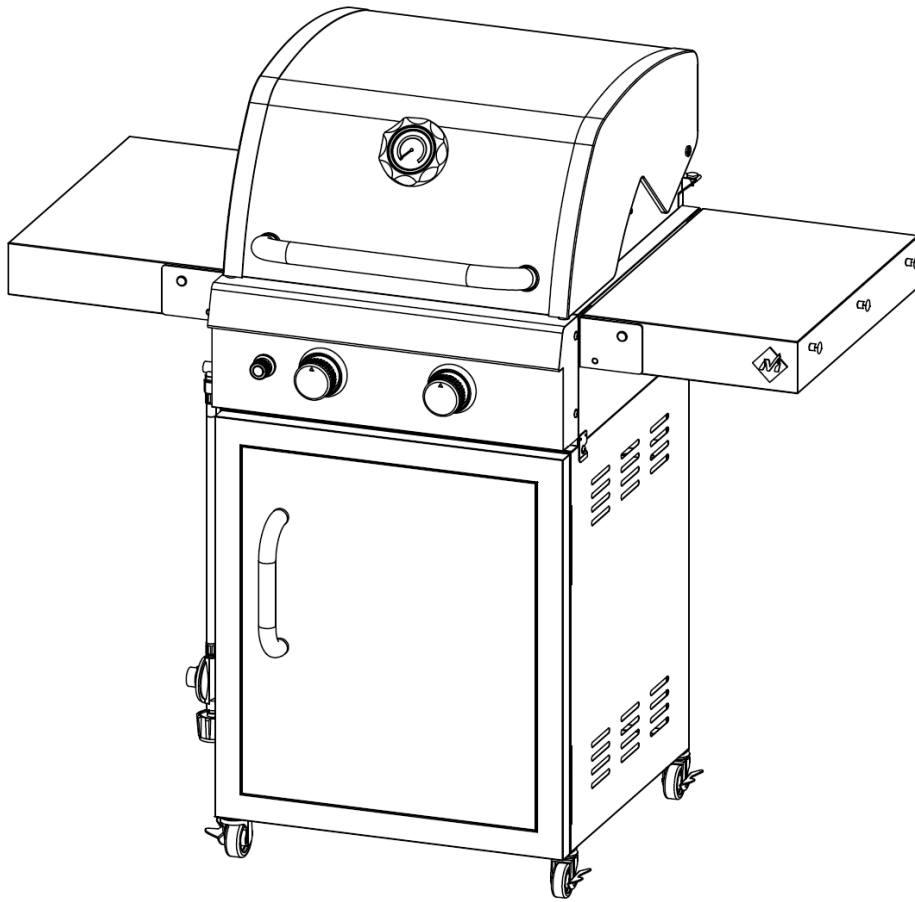

LEAK TEST

GENERAL

Although all gas connections on the grill are leak tested at the factory prior to shipment, a complete gas tightness check must be performed at the installation site due to possible mishandling in shipment, or excessive pressure unknowingly being applied to the unit.

Periodically check the entire system for leaks following the procedures listed below. Before using your grill you must check for leaks.

BEFORE TESTING

Make sure that all packing material is removed from the grill including the burner tie-down straps.

Make a soap solution of one part liquid detergent and one part water. You will need a spray bottle, brush, or rag to apply the solution to the fittings. For the initial leak test, make sure the LP cylinder is full.



WARNING



- DO NOT SMOKE WHILE CONDUCTING LEAK TEST.
- NEVER PERFORM LEAK TEST WITH AN OPEN FLAME.
- If it is evident that there is excessive abrasion, wear or the hose is cut, it must be replaced prior to the appliance being put into operation. The replacement hose must be specified by the manufacturer.

TO TEST

1. Make sure the control valves are in the **OFF** position then turn on the gas supply.

2. Check all connections from the gas cylinder, LP gas regulator and supply valve up to and including all connections to the pipe that go to the burners. The following are the points where the soap-water mixture is to be applied. Soap bubbles will appear if a leak is present.

- A Supply tank (cylinder) weld.
- B Connection nut to tank valve.
- C Back side of connection nut to brass nipple.
- D Brass nipple connections to gas supply hoses.
- E Regulator connections to gas supply hose.
- F The full length of gas supply hose.
- G Tank valve to cylinder.
- H Control knob and control valve pin.
- I Connections of hose and manifold.

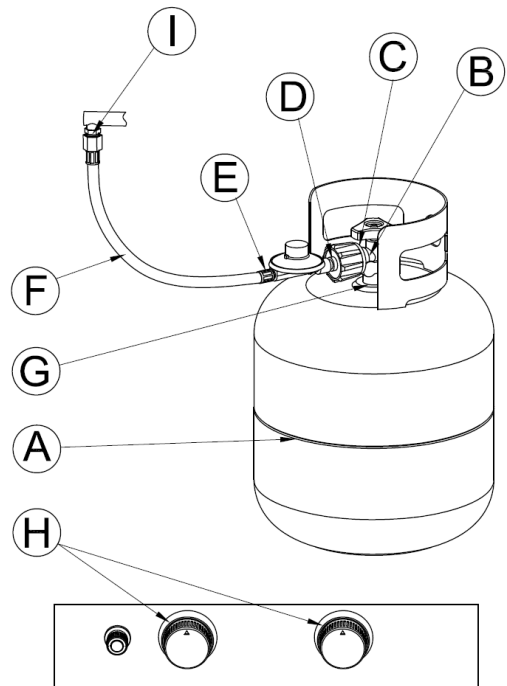

Watch For Bubbles



3. If a leak is present, immediately turn off the gas supply and tighten the leaky fittings.

4. Turn the gas back on and recheck.

5. Should gas continue to leak from any of the fittings, turn off the gas supply and contact customer service department at (888) 837-1380, 8 a.m. - 5 p.m., Pacific Standard Time, Monday - Friday.

LIGHTING INSTRUCTIONS

BEFORE LIGHTING



WARNING



- Inspect the gas supply hose prior to turning the gas **ON**.
- If there is evidence of cuts, wear, or abrasion, the hose must be replaced prior to use.
- Do not use the grill if the odor of gas is present.
- Only the pressure regulator and hose assembly supplied with the unit should be used.
- Perform the "**LEAK TEST**" according to the instructions before operating the grill
- **ALWAYS** keep your face and body away from the burner while lighting.

LIGHTING THE MAIN BURNER OF THE GRILL

1. Read instructions before lighting;
2. Open lid before lighting burner.
3. Make sure all control knobs are in the "**OFF**" position.

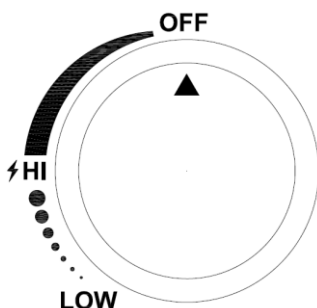

4. Turn ON gas valve from source or tank.
5. Push and turn any main burner control knob to "**HI**" and immediately press and hold the electronic ignition button.

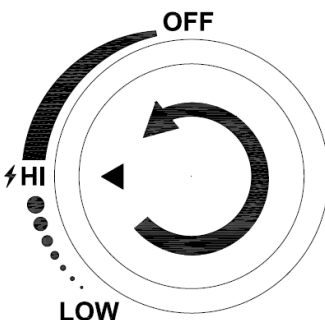

6. If ignition does NOT occur in 5 seconds, turn the burner control knob off, wait 5 minutes to allow gas to dissipate. Repeat the lighting procedure.
7. Repeat above steps to light each burner individually.

8. To turn burners off, turn the control knobs clockwise until they lock in the **OFF** position.

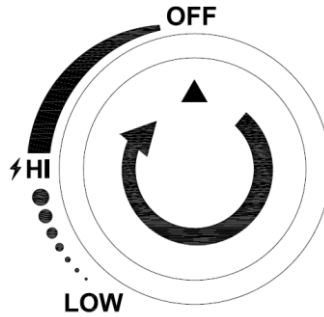

USING MATCH HOLDER TO LIGHT BURNER

1. Turn **OFF** all burner valves.
2. Make sure the lid is open.
3. Take the match holder from the cart rear panel.
4. Place a lighted match on the match holder and hold next to the burner.
5. Turn the control knob(s) to the "HI" position. Burner should light immediately.
6. If the burner does not light in 5 seconds, turn the knob off and wait for 5 minutes then repeat above procedures.

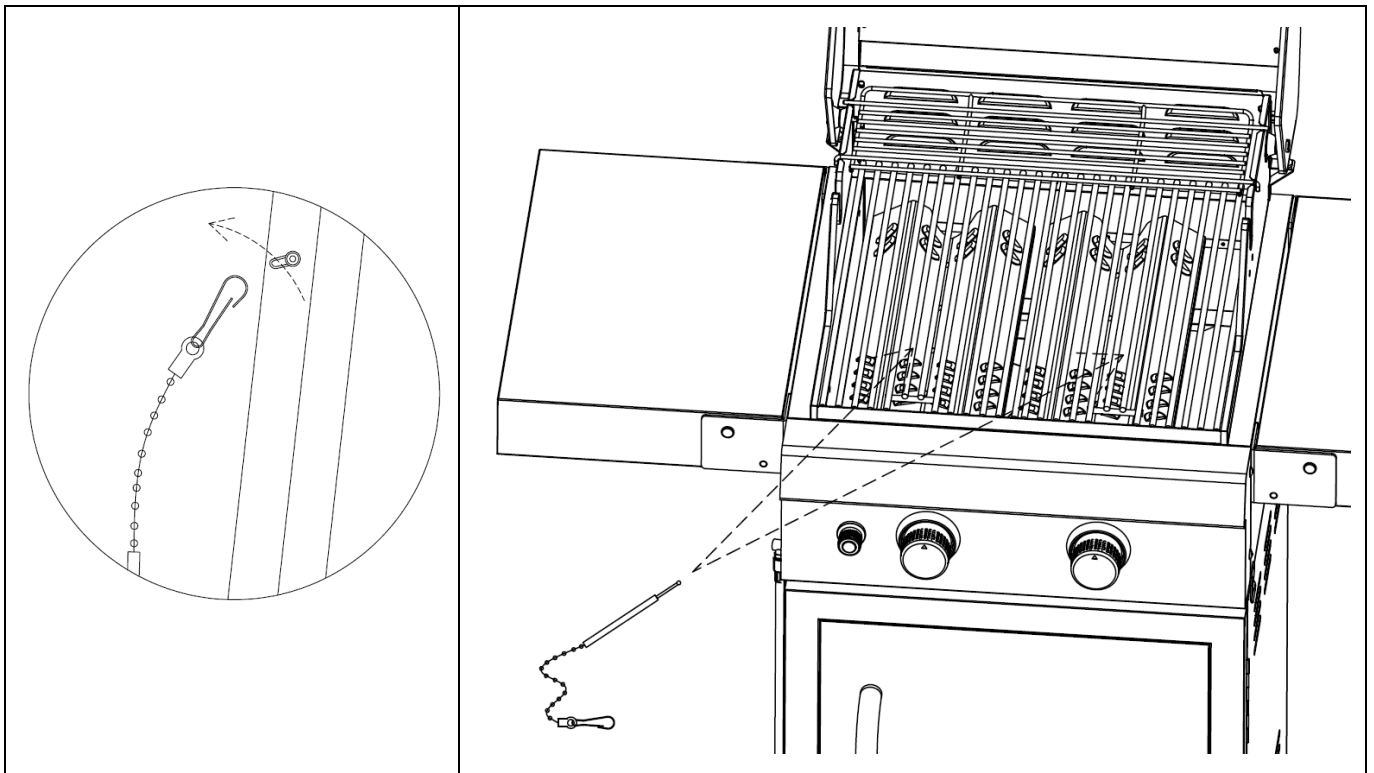

DANGER



- Keep your face and hands as far away from the grill as possible when lighting it.

FLAME CHARACTERISTICS

This procedure outlines how to check for proper burner flame characteristics.

Burner flames should be blue and stable with little yellow tips, with no excessive noise, or lifting. If the flame is yellow, it indicates insufficient air. If the flame is noisy and tends to lift away from the burner, it indicates too much air. If any of these conditions exist, call our customer service line. Visually check the burner flames prior to each use. The flames should look like this picture. If not, refer to the burner maintenance part of this manual.

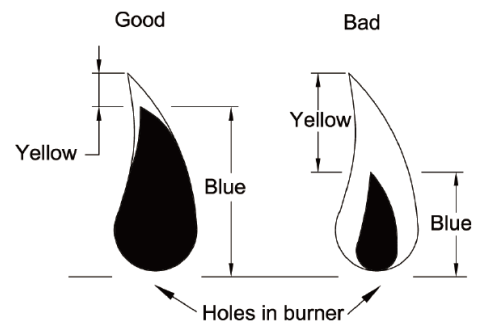

MAINTENANCE & CLEANING INSTRUCTIONS



CAUTION



- Keep outdoor cooking gas appliance area clear and free from combustible materials, gasoline and other flammable vapors and liquids.
- Do not obstruct the flow of combustible and ventilation air.
- Keep the ventilation openings of the cylinder enclosure free and clear of debris.
- Check and clean burner/venturi tubes for insects and insect nests. A clogged tube can lead to a fire beneath the grill.

STEEL SURFACES

There are different stainless steel cleaners available. Always use the mildest one for cleaning first and scrubbing in the direction of the grain. To touch up noticeable scratches in the stainless steel, sand very lightly with dry 100 grit emery paper in the direction of the grain. Specks of grease can gather on the surfaces of the stainless steel and bake on to the surface, giving the appearance of rust. To remove, use a soft abrasive pad in conjunction with a stainless steel cleaner.

GREASE CUP

The grease cup should be emptied, wiped down periodically, then washed with a mild detergent and warm water solution. Check the grease cup frequently. Don't allow excess grease to accumulate and overflow the grease cup.

GRILL BURNERS

Extreme care should be taken when removing a burner, as it must be correctly centered on the orifice before an attempt is made to relight the grill. Frequency of cleaning will depend on how often you use the grill.

Spiders and small insects occasionally spin webs or make nests in the grill burner tubes during transit and warehousing. These webs can lead to gas flow obstruction that could result in a fire in and around burner tubes. This type of fire is known as flashback and can cause serious damage to your grill and create an unsafe operating condition for the user.

Although an obstructed burner tube is not the only cause of flashback, it is the most common cause. To reduce the chance of flashback, you must clean the burner tubes before assembling your grill, and at least once a month in late summer or early fall when spiders are most active. Also, perform this burner tube cleaning procedure if your grill has not been used for an extended period of time.

You should inspect the burners at least once a year or immediately after any of the following conditions occur:

1. **The smell of gas in conjunction with the burner flames appearing yellow.**
2. **The grill does not reach temperature.**
3. **The grill heats unevenly.**
4. **The burners make popping noises.**

	<h1>WARNING</h1>	
<ul style="list-style-type: none">● ENSURE that the gas supply and the knobs are in the OFF position BEFORE cleaning the burners.		

BURNER CLEANING:

1. Turn off the gas supply, and make sure all the knobs are in the **OFF** position.
2. Wait for the grill to cool.
3. Open the lid and remove the cooking grate and heat distribution plate.
4. Remove the cotter pin and lift the burner out of the firebox.
5. Clean the exterior of the burner with a brass brush. Use a metal scraper to remove stubborn stains.
6. Clear clogged ports with a straightened paper clip. Never use a wooden toothpick as it may break off and clog the port.
7. If insects or other obstructions are blocking the flow of gas through the burner, call customer service at (888) 837-1380. Make sure to center the burner over the orifice.

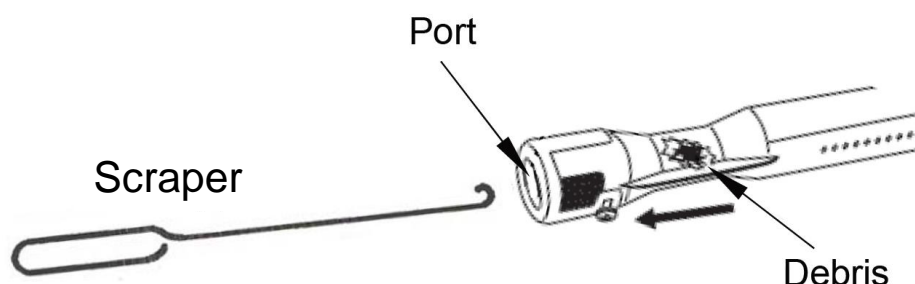

MAIN BURNER REPLACEMENT

1. Remove the warming rack, cooking grate and flame tamer.
2. Take out the burner cotter pin as shown.
3. Remove the burner fixing pin.
4. Unscrew the fixing bolt of the ignition electrode & wire.
5. Remove the burner from the grill body.

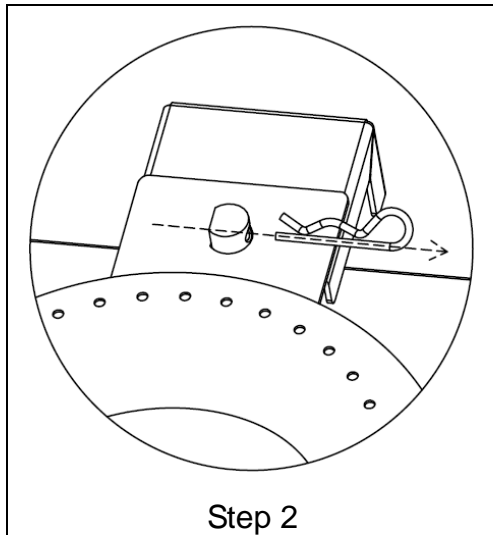

Step 2

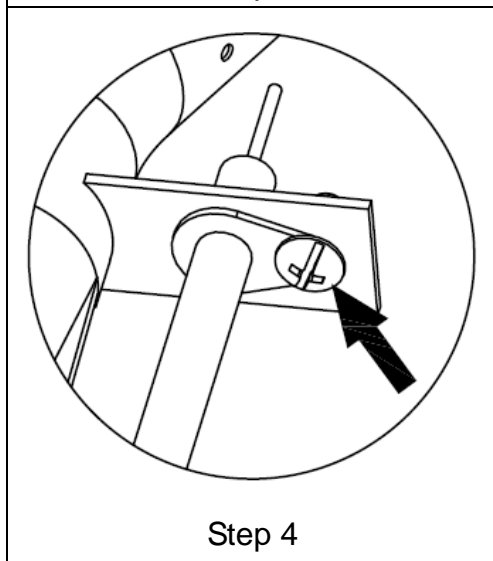

Step 4

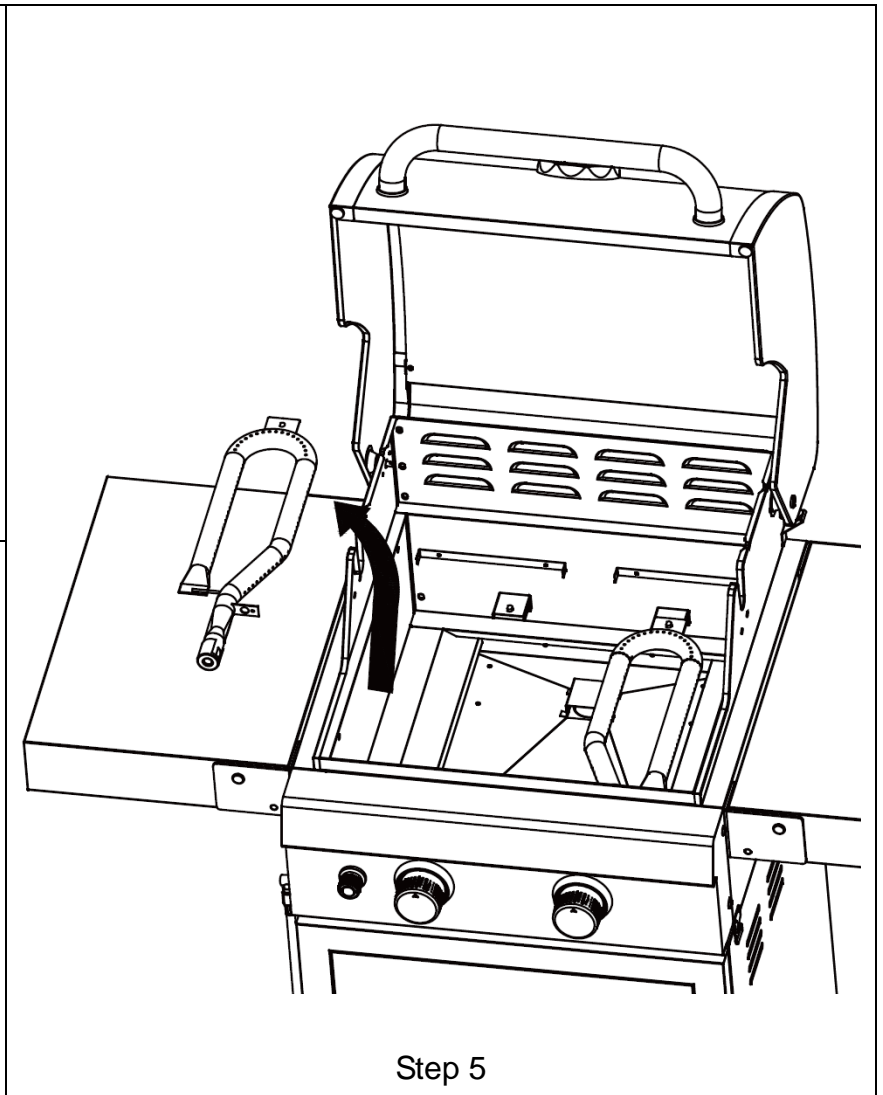

Step 5

TO REINSTALL THE MAIN BURNERS:

1. Reinstall the ignition electrode & wire to the burner.
2. Insert the burner into the burner valve.
3. Firmly seat the valve orifice into the burner tube. Make sure the valve orifice is inserted **STRAIGHTLY** into the burner tube as per below diagram.
4. Position the main burner onto the burner support at the firebox then align all the holes together. Insert the burner fixing pin through the holes and plug the cotter pin into the hole of the burner fixing pin.

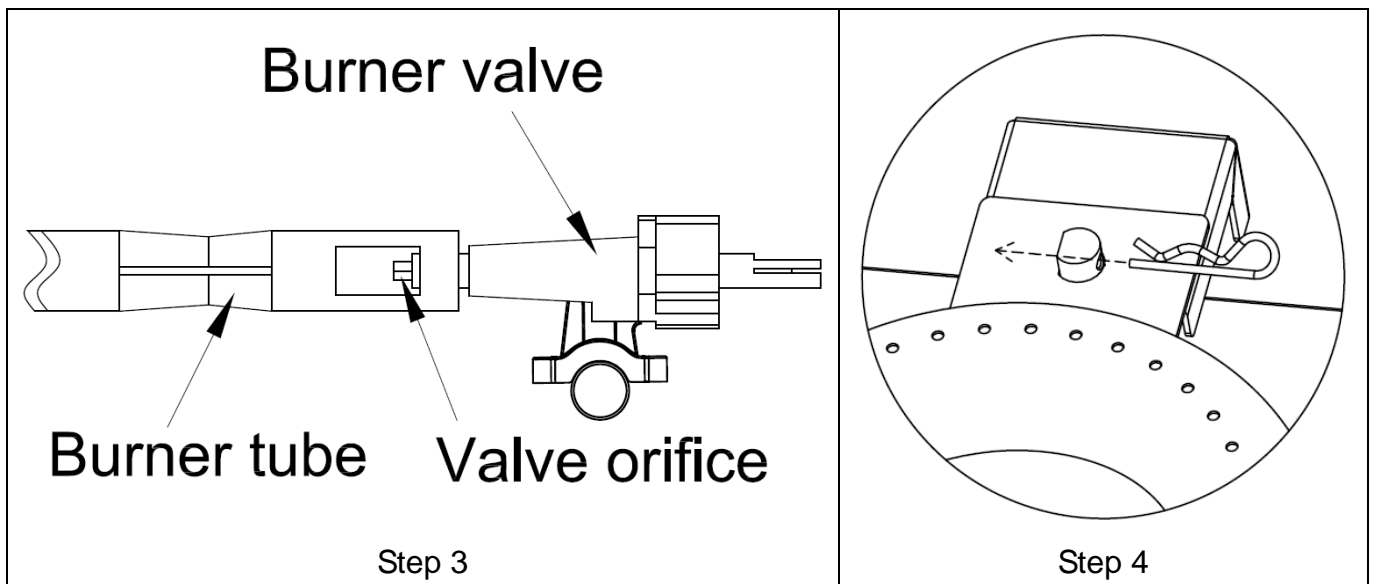

We would like to hear from you with any comments or suggestions. In the continental U.S or Canada, you can call us toll-free at 1.888.301.0332 from 8 a.m. to 5 p.m. CST Monday – Friday. You can also send us an email using the feedback icon at [SamsClub.com](mailto:Feedback@SamsClub.com). Call center for missing parts 1.888.837.1380

TROUBLE SHOOTING

Problem:	Possible Causes:	Corrective Actions:
Burner will not light	<ol style="list-style-type: none"> 1. LP cylinder fuel is used up. 2. Electrode tip not in proper position. 3. Burner may not be properly seated. 4. Burner may be obstructed. 5. Cylinder valve may be closed. 6. Regulator is not properly seated on cylinder valve. 	<ol style="list-style-type: none"> 1. Change a new full LP cylinder. 2. Tip of electrode should be pointing toward gas port opening on burner. The distance should be 1/8" to 1/4". Adjust if necessary. 3. Refer to the section of "To Reinstall The Main Burners" at P.30 to reinstall the burner properly. 4. Refer to the section of "Burner Cleaning" at P.28-29 to clean the burner. 5. Check then open the cylinder valve. 6. Refer to the section of "Connection Procedures" at P.6 to reinstall the regulator properly.
Fire at control knob	<ol style="list-style-type: none"> 1. Burner is improperly seated on control valve. 2. Gas connections may be loose. 3. Burner holes may be obstructed. 	<ol style="list-style-type: none"> 1. Refer to the section of "To Reinstall The Main Burners" at P.28 to reinstall burner properly. 2. Refer to the section of "Leak Check" at P.24-25 to check and tighten all connections. 3. Refer to the section of "Burner Cleaning" at P.28-29 to clean the burner.
Yellow flame at burner	<ol style="list-style-type: none"> 1. Burner is obstructed. 	<ol style="list-style-type: none"> 1. Refer to the section of "Burner Cleaning" at P.28-29 to clean the burner.
Flame blows out on "LOW"	<ol style="list-style-type: none"> 1. Burner holes may be obstructed. 2. Grill is not sufficiently preheated. 3. Burner is improperly seated on control valve. 	<ol style="list-style-type: none"> 1. Refer to the section of "Burner Cleaning" at P.28-29 to clean the burner. 2. Preheat the grill for sufficient time. 3. Refer to the section of "To Reinstall The Main Burners" at P.30 to reinstall burner properly.
Burner does not get hot enough	<ol style="list-style-type: none"> 1. Flow control device has been activated in regulator. 	<ol style="list-style-type: none"> 1. Reset the regulator. Turn off all burners and close the LP tank valve. Disconnect the regulator from the LP tank and wait for one minute. Reconnect the regulator to the LP tank and slowly open the LP tank valve until the valve is fully open. Light all burners and observe the temperature.
Grill is too hot	<ol style="list-style-type: none"> 1. Excess grease build-up causing grease fires. 2. Damaged or faulty regulator. 	<ol style="list-style-type: none"> 1. Refer to the section of "Maintenance and Cleaning instructions" at P.27-30 to clean the grill properly. 2. Replace the damaged parts with factory authorized component.

LIMITED WARRANTY

1. Manufacturer warrants this Product to be free from defects in workmanship and materials for a period of Ninety (90) days from the date of purchase, PROVIDED claims are submitted, in writing, with proof of purchase.
2. If any part of this item fails because of a manufacturing defect within the Limited Warranty Period, Manufacturer offers to replace such part(s) provide that such parts have not been improperly repaired, altered, or tampered with or subject to misuse, abuse or exposed to corrosive conditions. This Limited Warranty is, however, subject to certain limitations, exclusions, time limits and exceptions (Hereinafter "Conditions") as listed below. Read these Conditions carefully.
3. This Limited Warranty shall be limited to the replacement or repair of any part(s) which Manufacturer determines, after reasonable examination, to have been defective at the time of manufacturing and manufacturer's obligation(s) shall be limited to replacement, if any, of defective part(s) which shall be shipped at Original Purchaser's expense to Original Purchaser's designated shipping address.
4. This Limited Warranty is given to and covers the **ORIGINAL PURCHASER ONLY** and such coverage terminates Ninety (90) days from the date of purchase.
5. **DAMAGE LIMITATION WARNING:** IN NO EVENT SHALL MANUFACTURER BE LIABLE FOR ANY INCIDENTAL OR CONSEQUENTIAL DAMAGES, INCLUDING (BUT NOT LIMITED TO) LOSS OF USE OF THE PRODUCT, LOSS OF TIME, LOSS OF FOOD, INCONVENIENCE, EXPENSES FOR TRAVEL, TRANSPORTATION LODGING EXPENSES, LOSS BY DAMAGE TO PERSONAL PROPERTY OR LOSS OF INCOME, PROFITS OR REVENUE.
6. **MANUFACTURER'S OBLIGATION:** Manufacturer's liability shall be limited to the delivery of a good, merchantable Product and, if necessary, the repair or replacement, at manufacturer's option, of any defective part or unit.
7. **TRANSFER LIMITATIONS:** This Limited Warranty is not assignable or transferable. It covers only the original purchaser.
8. **RESERVED RIGHT TO CHANGE:** Manufacturer reserves the right to make changes or improvements to products it produces in the future without imposing on itself any obligations to install the same improvements in the products it has previously manufactured.
9. This Limited Warranty gives the Original Purchaser specific legal rights but there may be other rights which vary by jurisdiction.
10. This warranty does not cover the following items:
 - Chips or scratches on porcelain or painted surfaces.
 - Rust or corrosion is not deemed a manufacturing or materials defect.
 - Discoloration or loss of paint due to handling during assembly, heat or cleaning products. Paint may require touch up.
 - Stainless steel discoloration or corrosion.
 - Consumables such as batteries.

IF CUSTOMER SERVICE BECOME NECESSARY:

1. The Original Purchaser is responsible for shipping and handling charges of the returned item(s) and replacement parts, if any.
2. All parts to be replaced will need to be shipped before replacement items will be sent.
3. Follow the Customer Service Representative's instructions exactly. If a return is necessary, it must be packed carefully and shipped prepaid.

Should you encounter any problem,
CALL US FIRST.

Do not return product to the store.
WE CAN HELP.

For assistance, contact customer service at customerservice@rankam.com
or at (888) 837-1380, Mon to Fri, 8:00am – 5:00pm Pacific Standard time

Manufacturer information

Rankam (China) Manufacturing Company Limited

Address: 18/F., New Lee Wah Centre, 88 Tokwawan Road, Kowloon, Hong Kong.