

DREXEL

Push Back Recliner

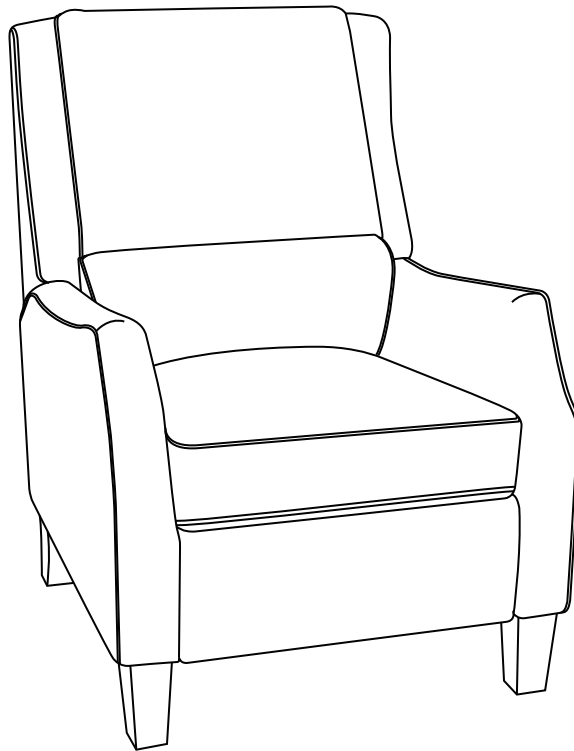

Assembly and Care Instructions

IMPORTANT, RETAIN FOR FUTURE REFERENCE: READ CAREFULLY.

M# 1761S-8524S-96

THIS CHAIR CAN SUPPORT UP TO:
CE CHAISE PEUT SUPPORTER JUSQU'À:
ESTE SILLA PUEDE SOPORTAR HASTA:
113.4 kg / 250 lb
PER SEAT / PAR PLACE / POR ASIENTO

Important Safety Information

- *Please read all instructions carefully before assembling this furniture.*
- *For your safety, assembly by two or more adults is strongly recommended.*
- *Use only vendor-supplied hardware to assemble this item. Using unauthorized hardware could jeopardize the structural integrity of the item.*
- *Hardware may loosen overtime. Periodically check that all connections are tight.*

Before Assembly

- *Remove all parts and hardware from the box. Place all items on a carpeted or scratch-free work surface, as this will avoid damaging parts during assembly.*
- *The shipping box provides an ideal work surface.*
- *To avoid accidentally discarding small parts or hardware, do not dispose of any packaging or contents of the shipping carton until assembly is complete.*
- *Use the parts and hardware lists below to identify and separate each of the pieces included.*
- *The use of power tools for assembly is not recommended. Power tools can damage the hardware and/or split the wood.*

Care and Cleaning

- *Dust often and use a vacuum cleaner crevice tool to clean seams. To maintain the appearance, gently clean soiled areas with a soft cloth dampened with a mild, water based detergent. Remove all lather and wipe with a clean damp cloth. Dry with another soft cloth by blotting the damp surface (do not rub).*
 - *Do not place furniture in direct sunlight and keep furniture at least 60 cm / 2 ft from heat sources to avoid fading.*
-

PARTS/PIÈCES/PIEZAS

A

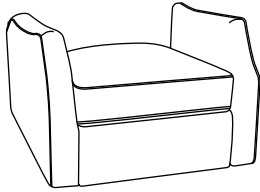

Seat Cushion x 1

B

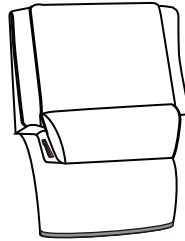

Back Cushion x 1

C

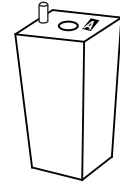

Front Wood Legs x 2

D

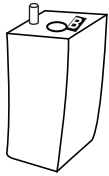

Back Wood Legs x 2

E

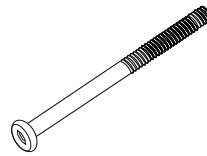

5/16"x5.25" L Screw
(for front wood legs) x 2

F



5/16"x3" L Screw
(for back wood legs) x 2

G



Spring Washer x 4

H



Flat Washer x 4

I

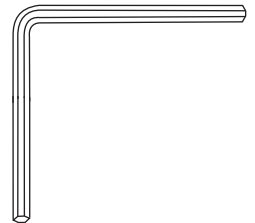

Hex Wrench x 1

Attention:

1. Do not stand on the seat cushion.
2. For indoor use only.
3. Please do not expose to direct sunlight.
4. Please do not place this product near sources of excessive heat.
5. Please avoid use of sharp objects on or near this product.
6. Use Fabric Cleaner on spills and marks, as general household cleaners can damage fibers and discolor fabrics.
7. Clean spills / marks immediately, as stains are harder to remove when they are left unattended.
8. For persistent stains and overall cleaning, contact a professional upholstery cleaning company.

Step 1

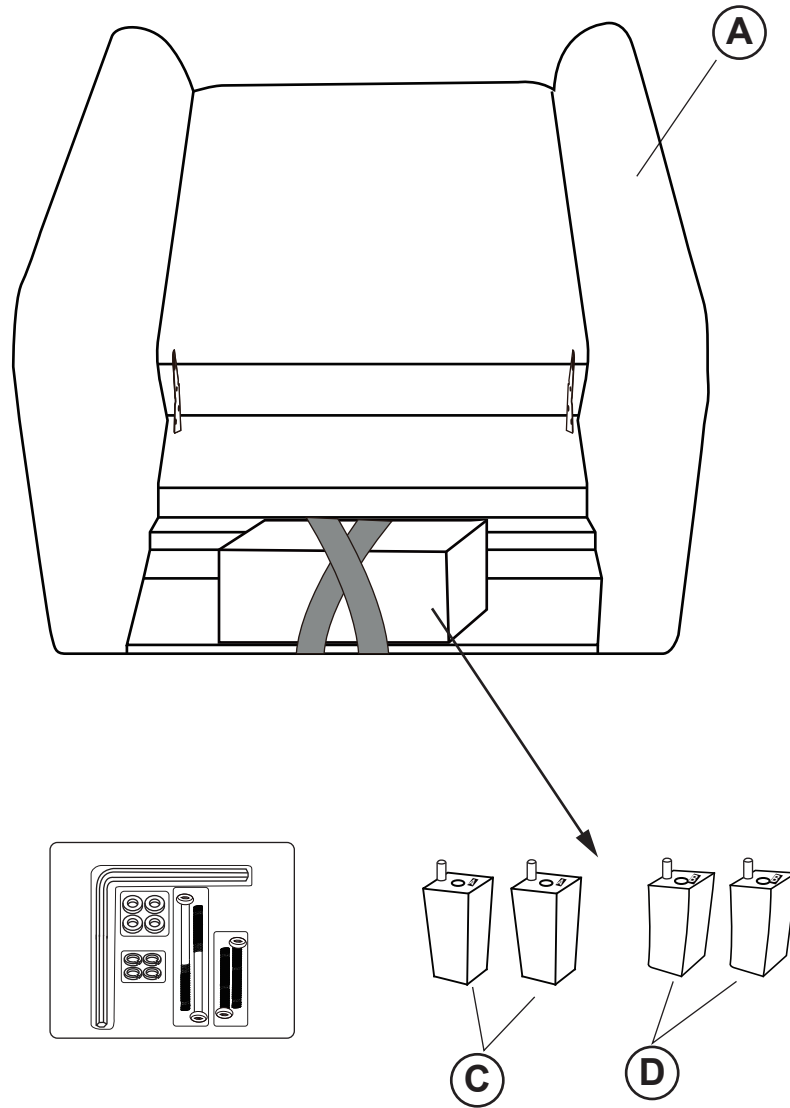

1

Remove all parts from the carton and place them on a protected surface or carpet. Take out the Wood Legs (C & D) and Hardware package from box at the back of the Seat Cushion (A).

Step 2

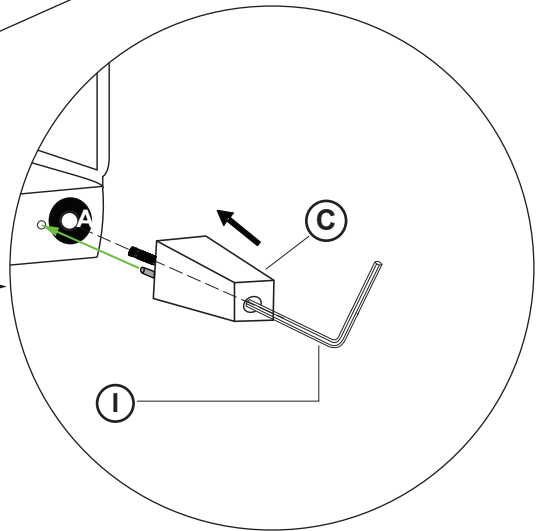
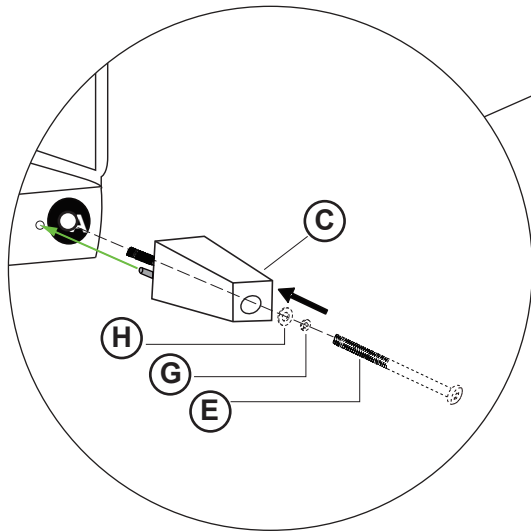
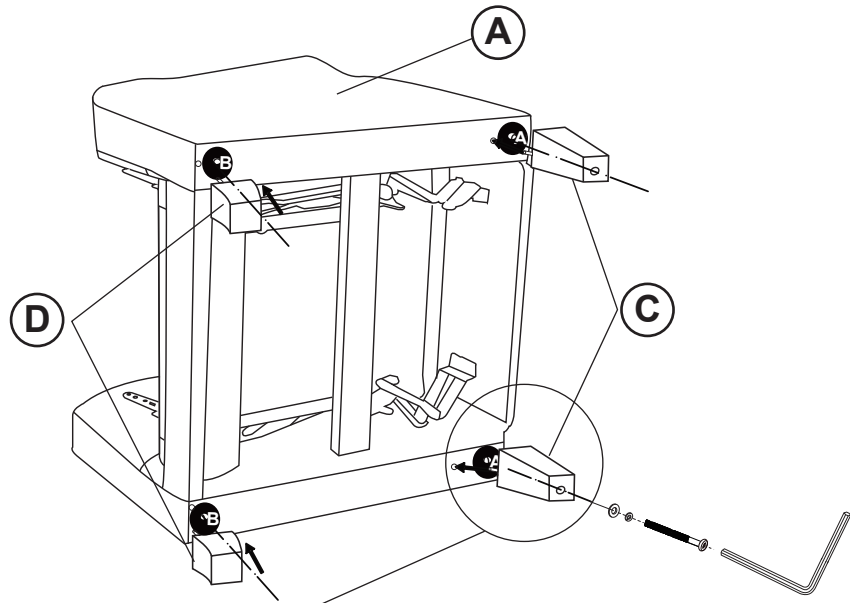
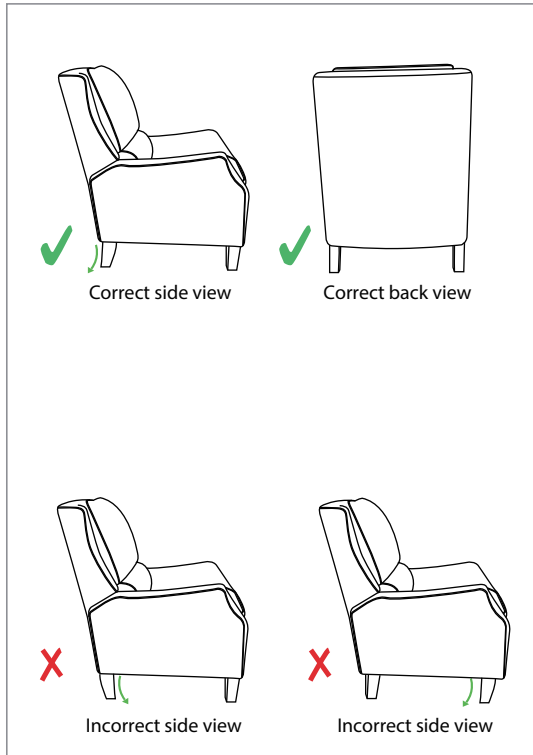

2

When assembling the Front and Back Wood legs (C&D), align the hole at the bottom of the Seat Cushion (A) with the wood dowel onto the wood legs, screw and washers first, then attach Front and Back Wood Legs (C&D) to the bottom of the Seat Cushion (A) using 5/16" × 5.25" L Screws (for front wood legs) (E) and 5/16" × 3" L Screws (for back wood legs) (F) , Spring Washer (G) and Flat Washer (H) with Hex Wrench (I) as shown.

Step 3

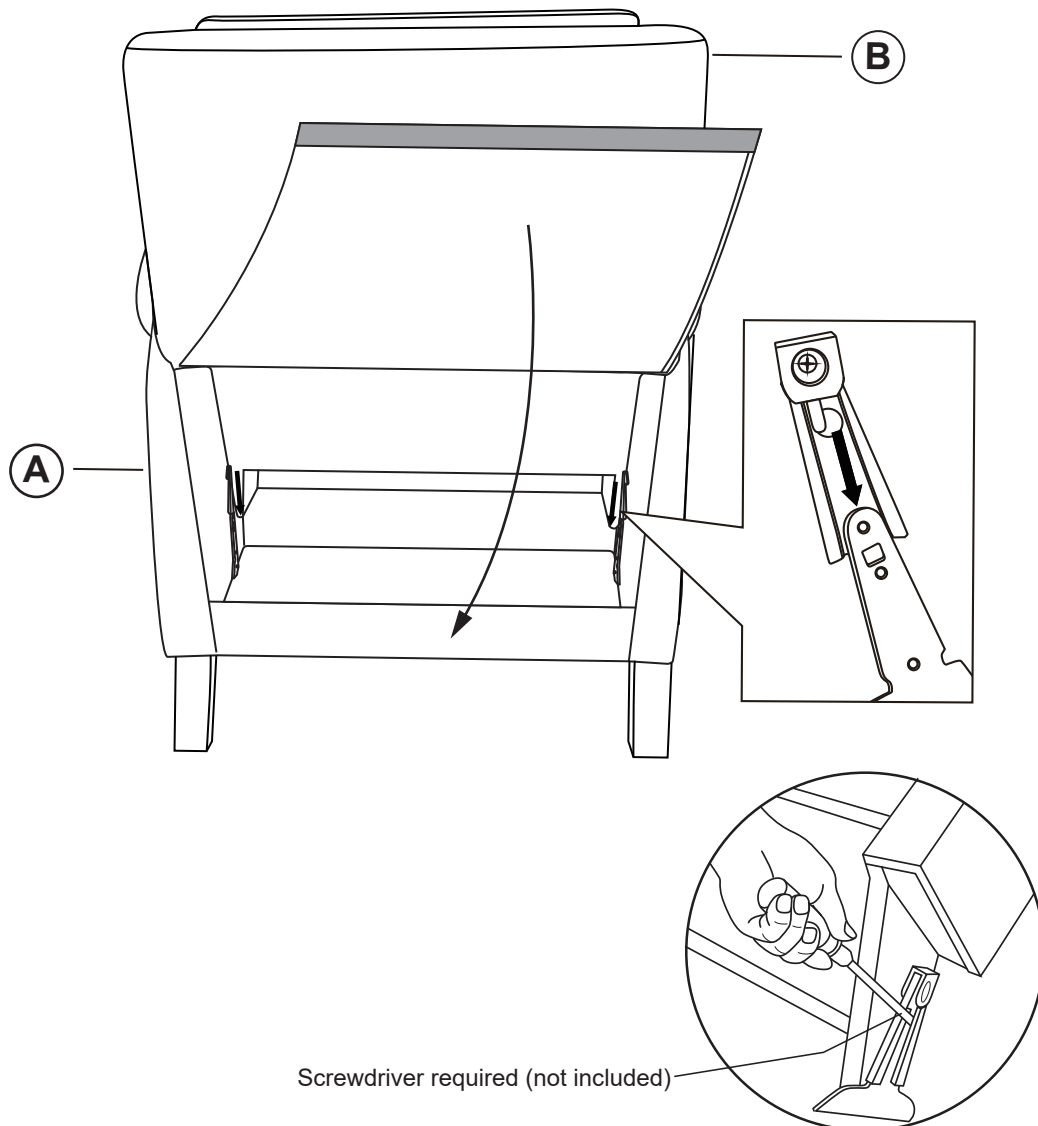

3

Attach the Back Cushion (B) to the Seat Cushion (A) by sliding the receivers into the mechanism posts located on the Seat Cushion (A). From the front of the recliner, press down on both sides of the Back Cushion (B) to firmly secure. The Back Cushion (B) and Seat Cushion (A) will automatically lock into place. Then pull the back flap down tightly and attach the back flap to the bottom of the Seat Cushion (A). To remove the back, use a screwdriver pressing outward on the black tab in the receiver on both sides and lift the back from the base.

Step 4

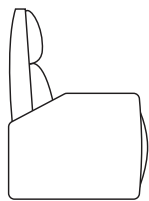
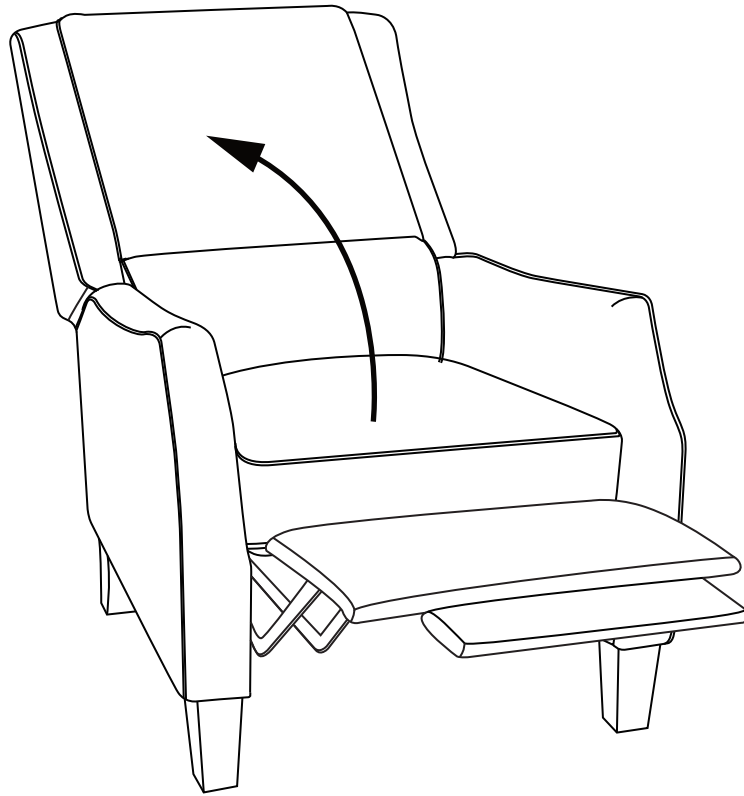

SIT

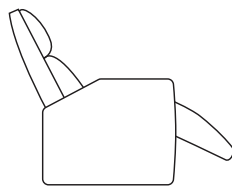

TV POSITION

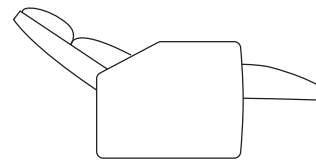

FULL RECLINE

4

While seated, push onto the back cushion to recline. It will move backwards raising the footrest at the same time. To return the footrest to the closed position, apply more weight onto the footrest.

Limited Warranty

True Innovations seating products are warranted against defects in material and workmanship while owned by the “Original Purchaser”. The term “Original Purchaser” is defined as that party or entity which purchases True Innovations furniture from an authorized True Innovations retailer as shown by the original sales receipt. This warranty does not apply to “as is” or previously owned seating products.

True Innovations warrants its products to be free from defects in materials and workmanship (normal wear and tear, fading and stretching excepted), for one year from the date of purchase, except as provided below under the limited warranty.

The exceptions or exclusions to this warranty are as follows:

1. Any warranty claim that is submitted after the limited warranty period, or without proper proof of purchase will not include the cost of parts, labor, or delivery.
2. This warranty shall not apply to the True Innovations products which have been subjected to misuse, neglect, alteration, modification, or attachments, either caused by the original purchaser, shipping, storage, accident, fire, flood, or acts of God.

In the event of a defect in material or workmanship covered by this warranty, True Innovations will repair or replace, at their discretion, without charge the warranted furniture within a reasonable amount of time. We reserve the right to require damaged parts to be returned to us upon request. Natural markings such as scars, brands, grain variations, wrinkles, color variations, etc., will be considered normal characteristics and not construed as defects. We cannot warrant leather against scratching or scuffing, as all leather is subject to blemishes with use.

For claims or questions concerning this warranty, please contact True Innovations Customer Service department on the web at www.trueinnovations.com. Be prepared to provide your name, address, daytime phone number, the model and purchase order number of the product, date of purchase, and the store where it was purchased. True Innovations requires that the original sales receipt be submitted with all requests to confirm that you are the original purchaser according to our written warranty.

All warranties are limited to the original purchaser for normal use by a person weighing less than 113.4 kg / 250lb.

AUSTRALIA: Our goods come with guarantees that cannot be excluded under the Australian Consumer Law. You are entitled to a replacement or refund for a major failure and for compensation for any other reasonably foreseeable loss or damage. You are also entitled to have the goods repaired or replaced if the goods fail to be of acceptable quality and the failure does not amount to a major failure.