



Assembly Instructions & User's Manual

Member's Mark™ 35inch Barrel Grill With Offset Smoker

Item Number: 990363435

Model Number: SXQ884S

Customer Assistance (spare/replacement parts): 1-866-273-2284
or Email: customerservice@sumxing.com

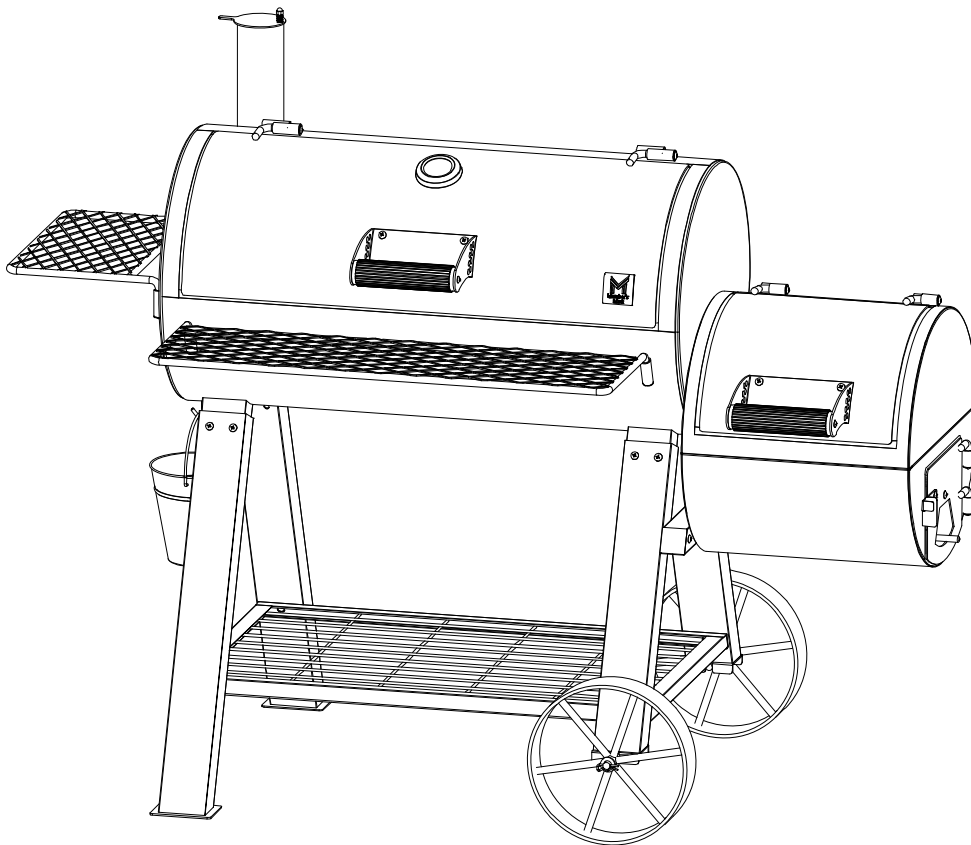

**THIS ASSEMBLY MANUAL CONTAINS IMPORTANT SAFETY INFORMATION.
PLEASE READ AND KEEP FOR FUTURE REFERENCE.**



Assembly Instructions & User's Manual

Table of Contents

Quality Statement	3
Important Safety Information	3
Before Assembly.....	3
Preparation For Use and Charcoal Lighting Safety	4
Package Contents	6
Product Information.....	7
Components.....	7
Hardware.....	8
Tools	9
Step 1 – Step 11	10
Grill Use Safety	17
After Use Safety	18
Troubleshooting.....	18
Care & Use Instructions	19
Limited Warranty Information	22

 **WARNING**

OUTDOOR USE ONLY! NEVER USE INDOORS!



Assembly Instructions & User's Manual

Quality Statement

Question or Comments? We would love to hear about your Member's Mark experience!

Visit us at: [Samsclub.com/membersmarkhelp](https://samsclub.com/membersmarkhelp)

Important Safety Information

- Please read all instructions carefully before assembling this product.
- Where applicable, and for your safety, assembly by an adult is strongly recommended.
- Use only vendor-supplied hardware to assemble this item. Using unauthorized hardware could jeopardize the structural integrity of the item.
- Hardware may loosen overtime. Periodically check that all connections are tight.

WARNING

CALIFORNIA PROPOSITION 65

 **WARNING:** This product can expose you to carbon monoxide, which is known to the State of California to cause birth defects or other reproductive harm.
For more information go to www.P65Warnings.ca.gov.

Before Assembly

- Remove all parts and hardware from the box. Place all items on a carpeted or scratch-free work surface, as this will avoid damaging parts during assembly.
- The shipping box can provide an ideal work surface if none is available.
- Use the components and hardware lists below to identify, inventory and separate each of the hardware and components included.
- To avoid accidentally discarding small components or hardware, do not dispose of any packaging or contents of the shipping carton until assembly is complete.
- DO NOT USE power tools unless it is explicitly identified in this manual as required for use during assembly. Power tools can damage the fasteners, hardware and/or components.
- Do not fully tighten all fasteners / screws until all parts are in place. Failure to follow these instructions may cause the fasteners / screws to misalign during assembly.
- DO NOT use this grill without the ash catcher / ash pan / or ash tray in place.
- DO NOT use this grill unless all parts are in working condition and properly installed.
- We recommend two people for assembly of this grill.
- Use caution during assembly and while operating your grill to avoid scrapes or cuts from sharp edges of metal parts. Use care when reaching into or under grill.



Assembly Instructions & User's Manual

Preparation For Use and Charcoal Lighting Safety

First Use Instructions

- Ensure all labels and packaging materials have been removed from the grill.
- Before cooking, burn off any manufacturing oils by operating the charcoal grill for at least 10 minutes with the lid closed. This "heat cleaning" process will clean the internal parts and eliminate any odors before you start grilling.

Charcoal lighting instruction

Lightly coat all interior surfaces of the grill with vegetable oil or vegetable oil spray. Do not coat charcoal grate, or charcoal ash tray.

Follow the instructions below carefully to build a fire. You may use charcoal and/or wood as fuel in the grill (see 'Adding Charcoal/Wood During Cooking' section in this manual)

NOTE: To extend the life of the grill, make sure that hot coals and wood do not touch the walls of grill.

IMPORTANT: Never use charcoal that has been pre-treated with lighting fluid. Use only a high-grade plain charcoal or charcoal/wood mixture.

Do not use gasoline, kerosene or alcohol for lighting charcoal. Use of any of these or similar products could cause an explosion possibly leading to severe bodily injury.

We recommend a charcoal chimney starter to avoid the dangers of charcoal starter fluid.

ALWAYS read and follow the chimney starter manufacturer's instructions and warnings regarding the use of their product. Start with 5 pounds (2.3 kgs) of charcoal, which should be enough to cook with once the curing process has been completed. When the charcoal is burning strong and exhibits graying around the edges, carefully place hot coals on charcoal grate.

If using charcoal starter fluid, **ONLY** use starter fluid approved for lighting charcoal. NEVER use gasoline, alcohol, kerosene, or any other highly flammable liquid. Use of any of these or similar products could cause an explosion, possibly leading to severe bodily injury. Carefully read the charcoal and starter fluid manufacturer's warnings and instructions before using this grill. Start with 8 to 10 pounds (3.6 to 4.5 kgs) of charcoal. Once the curing process has been completed, place the charcoal in the center of charcoal grate.

Saturate charcoal with lighting fluid. With lid open and charcoal grate completely placed inside the grill, wait for 2 to 3 minutes to allow lighting fluid to soak into charcoal. Store charcoal lighting fluid at a safe distance from the grill.

NOTE: ALWAYS clean up any starter fluid spills before lighting charcoal!

With grill lid open, stand back and carefully light charcoal and allow it to burn until covered with light ash (approximately 20 minutes).



Assembly Instructions & User's Manual

ALWAYS allow charcoal starter fluid to completely burn off prior to closing the grill lid. Failure to do so could trap fumes in the grill and might result in a flash fire or explosion when the lid is opened. Maximum charcoal weight 10 pounds (4.5 kgs)

⚠ Danger

- NEVER add charcoal starter fluid to hot or warm coals. Flare-ups could occur and cause burns.
- ALWAYS store charcoal starter fluid safely away from grill. DO NOT store starter fluid or other flammable liquids or materials under the grill.

IMPORTANT:

Make sure the grill is not scraped or rubbed during the curing process.



Assembly Instructions & User's Manual

Package Contents

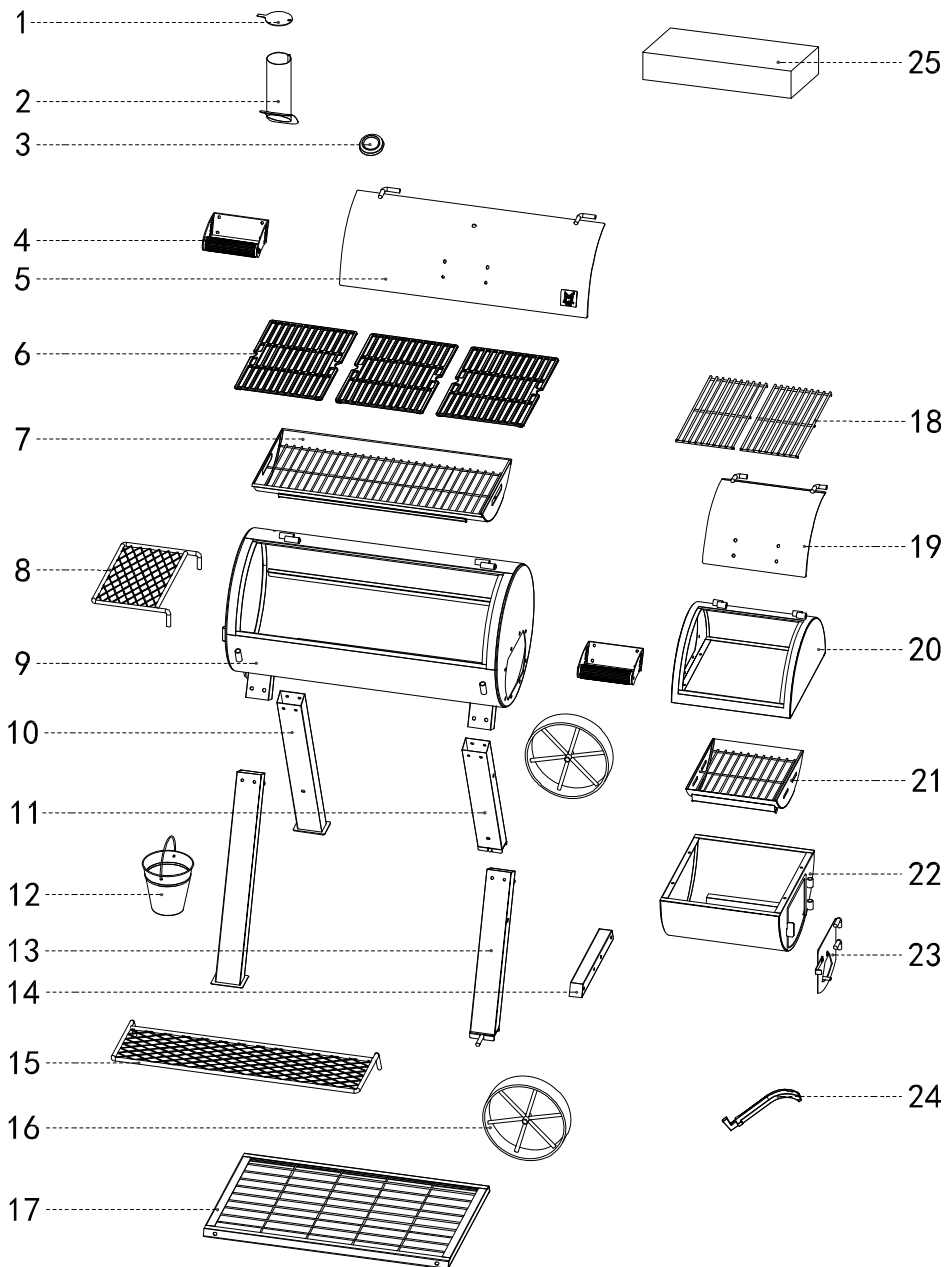



Assembly Instructions & User's Manual

Product Information

Product Dimensions –63inx35.43inx48.82in (160cmx90cmx124cm)

Components

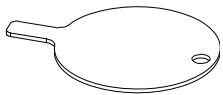
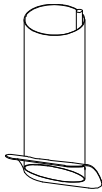
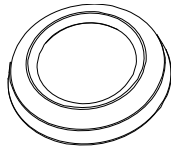
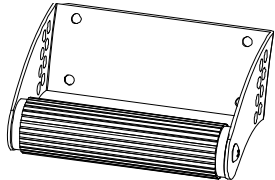
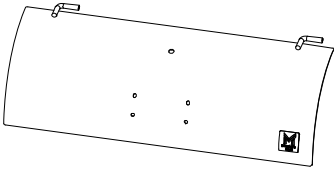
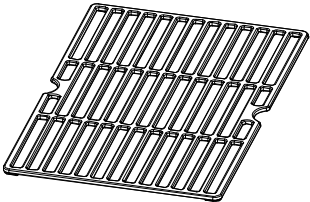
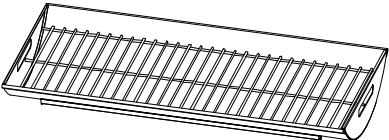
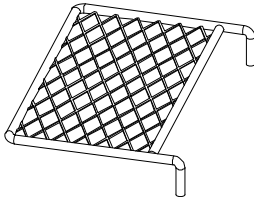
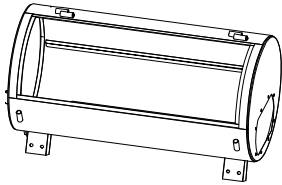
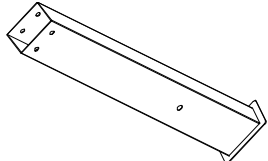
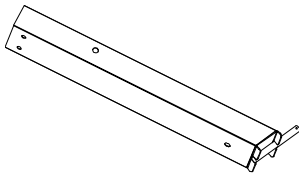
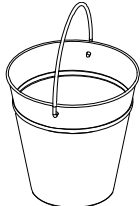
<p>1. Chimney cover QTY:1</p> 	<p>2. Chimney QTY:1</p> 	<p>3. Temperature gauge Qty: 1</p> 
<p>4. Lid handle Qty: 2</p> 	<p>5. Main grill lid Qty:1</p> 	<p>6. Main cooking grate Qty: 3</p> 
<p>7. Main charcoal brazier Qty:1</p> 	<p>8.Side shelf Qty: 1</p> 	<p>9. Main grill body Qty: 1</p> 
<p>10.Left support leg Qty: 2</p> 	<p>11.Right back support leg Qty: 1</p> 	<p>12. Grease bucket Qty:1</p> 



Assembly Instructions & User's Manual

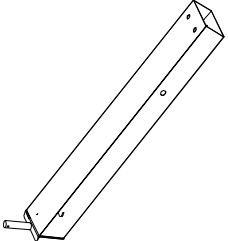
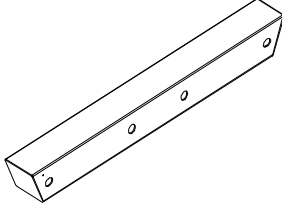
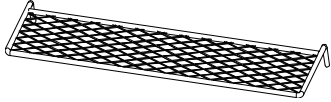
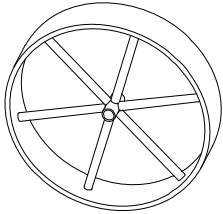
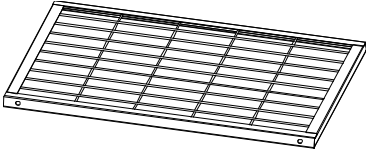
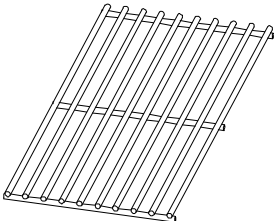
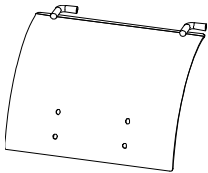
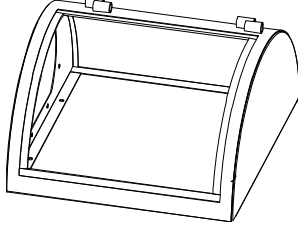
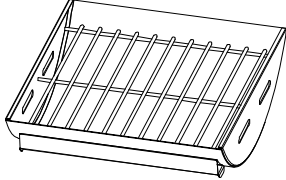
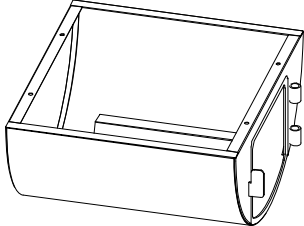
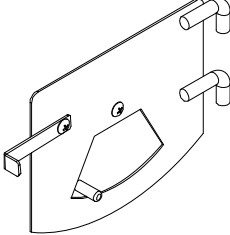
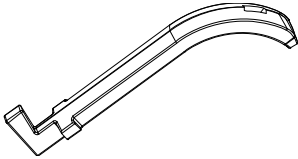
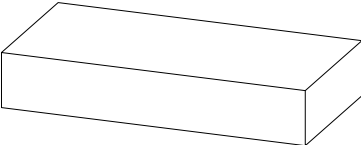







<p>13. Right front support leg Qty:1</p> 	<p>14. Side grill support bar Qty:1</p> 	<p>15. Front shelf Qty:1</p> 
<p>16. Wheel Qty:2</p> 	<p>17. Bottom rack Qty:1</p> 	<p>18. Side cooking grate Qty: 2</p> 
<p>19. Side grill lid Qty:1</p> 	<p>20. Side grill upper body Qty:1</p> 	<p>21. Side charcoal brazier Qty:1</p> 
<p>22. Side grill bottom body Qty:1</p> 	<p>23. Side charcoal door Qty:1</p> 	<p>24. Main cooking grate lifter Qty:1</p> 
<p>25. Grill cover Qty:1</p> 		

Need Assistance? Visit us at: samsclub.com/membersmarkhelp

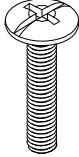



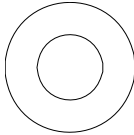

Assembly Instructions & User's Manual

Hardware

<p>A: M8*12 Bolt Qty: 20</p> 	<p>B: M6*15 Bolt Qty: 34</p> 	<p>C: M6*50 Bolt Qty: 2</p> 
<p>D: M6 Washer Qty: 20</p> 	<p>E: M6 Nut Qty: 22</p> 	<p>F: Damper Spring Qty: 1</p> 
<p>G: M6 Cap Nut Qty: 1</p> 	<p>H: Washer for Wheel Qty: 2</p> 	<p>I: Cotter Pin Qty: 2</p> 

Spare Hardware

<p>A: M8*12 Bolt Qty: 2</p> 	<p>B: M6*15 Bolt Qty: 2</p> 	<p>D: M6 Washer Qty: 2</p> 
<p>E: M6 Nut Qty: 2</p> 		

Tools

Phillips Screwdriver (Not Included)





Assembly Instructions & User's Manual

Step 1

1. Place the Main Grill Body (9) on a soft, non-scratch surface, such as a carpet or protective mat.
2. Remove the Main Grill Lid (5) from the Grill Body by unscrewing the two M6 x 15 Bolts (B) with a screwdriver, then remove the two M6 Washers (D).
3. Carefully take out all parts stored inside the Main Grill Body.

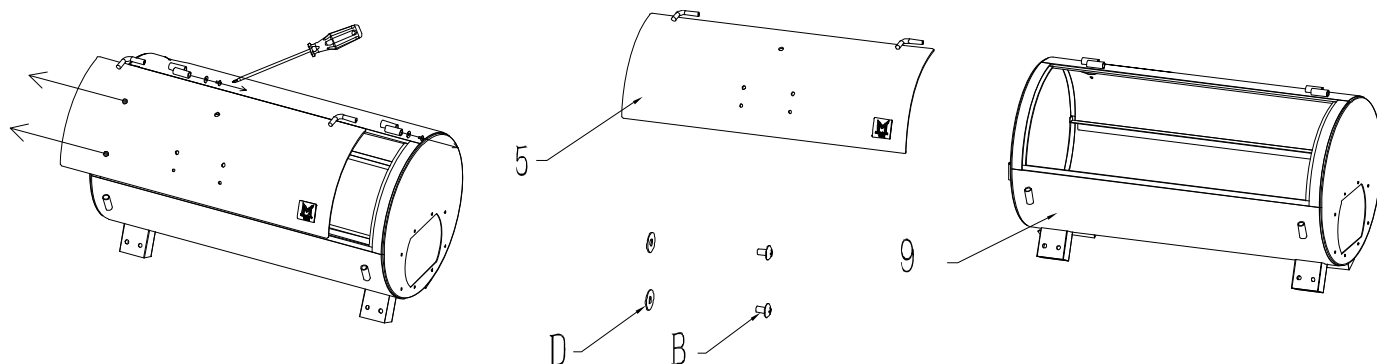

Step 2

1. Assemble the Support Legs (10), (11), and (13) to the Main Grill Body (9) using 16 M8 x 12 Bolts (A).
2. Make sure the legs align with the correct holes as shown in the diagram below.

Tip: Double-check the orientation of the legs to ensure proper alignment before tightening the bolts.

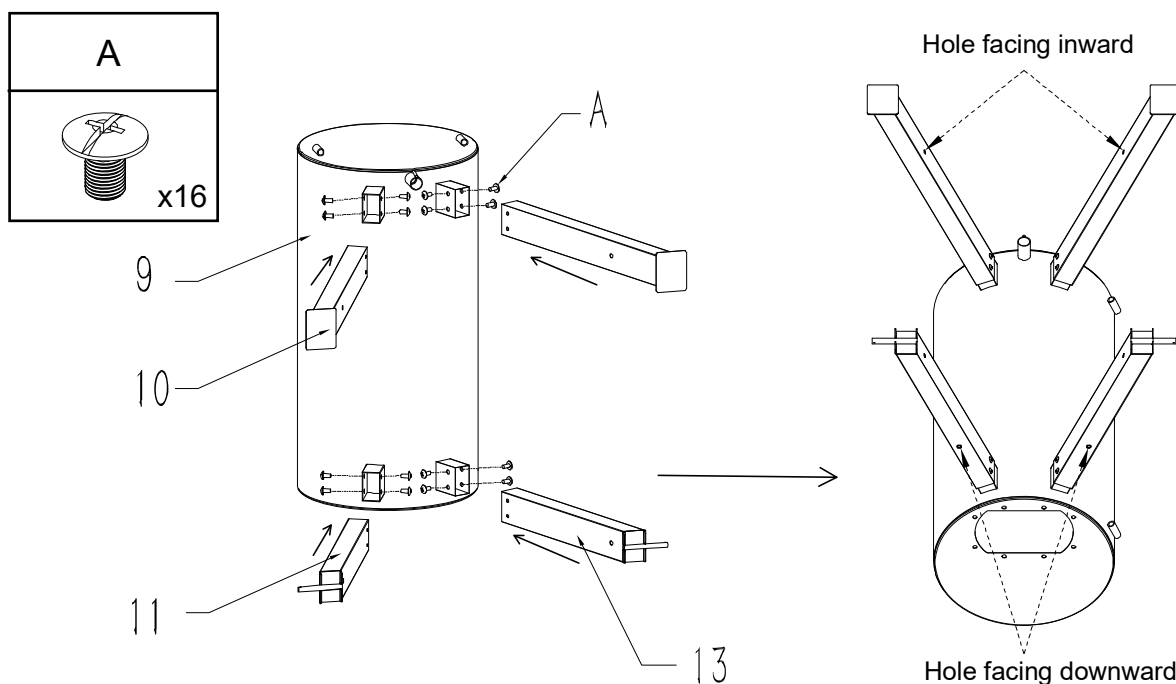



Assembly Instructions & User's Manual

Step 3

1. Attach the Bottom Rack (17) to the Support Legs using 4 M8 x 12 Bolts (A).
2. Assemble the Wheels (16) onto the Support Legs by securing them with 2 Washers (H) and 2 Cotter Pins (I).

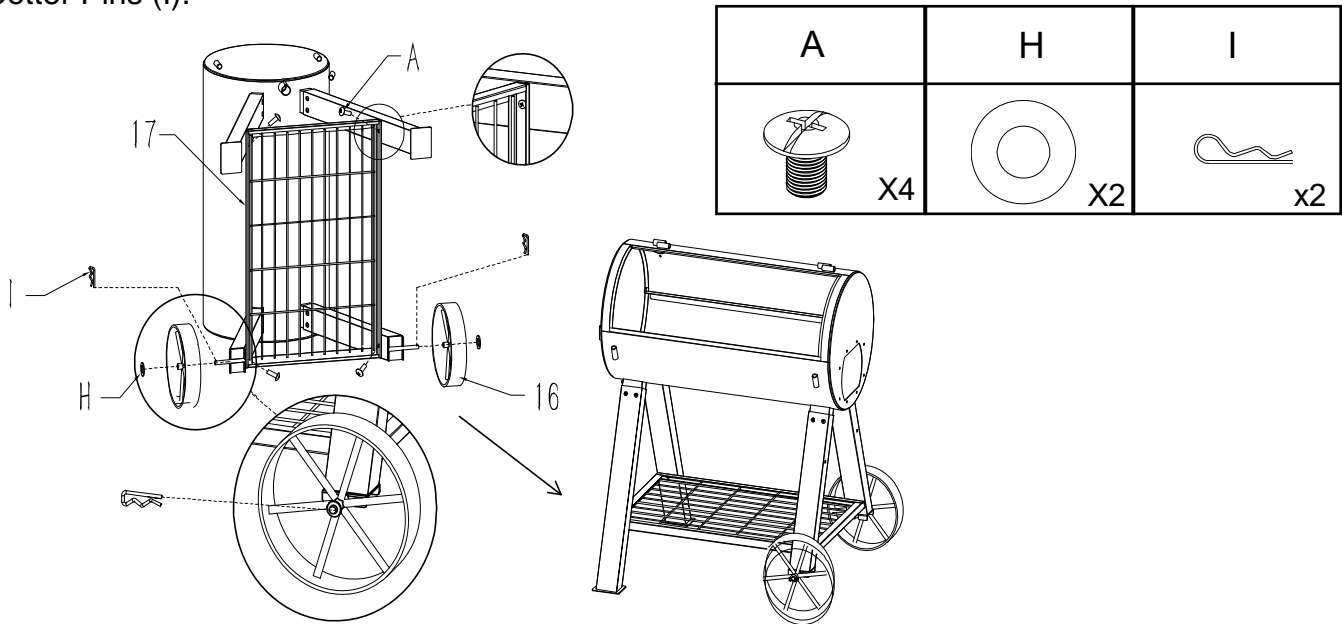

Step 4

1. Attach the Chimney (2) to the Grill Body using 2 M6 x 15 Bolts (B), 2 M6 Washers (D), and 2 M6 Nuts (E).
2. Secure the Chimney Cover (1) by attaching it with 1 Damper Spring (F) and fastening it with 1 M6 Cap Nut (G).
3. Fasten the Side Grill Support Bar (14) to the Support Legs using 2 M6 x 50 Bolts (C).

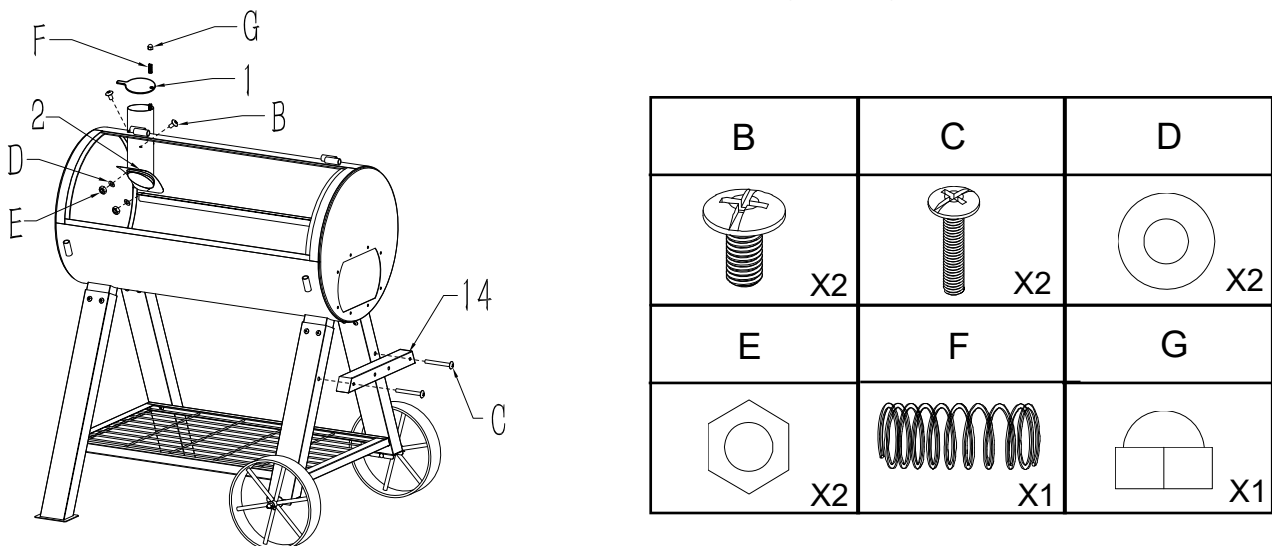





Assembly Instructions & User's Manual

Step 5

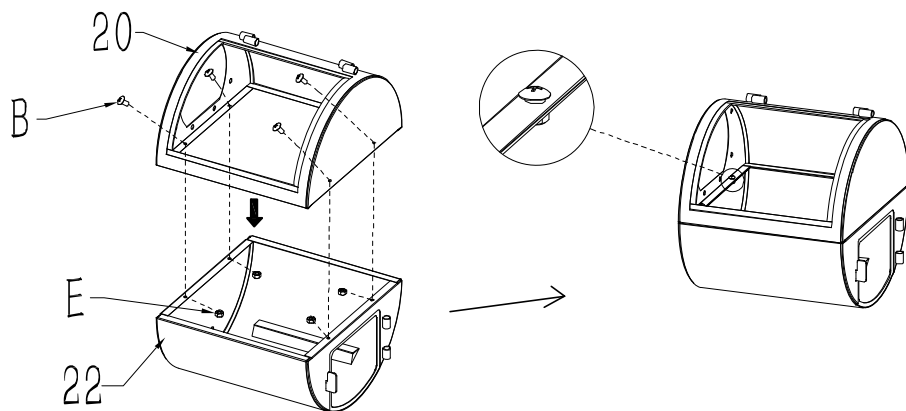
Connect the Side Grill Upper Body (20) to the Side Grill Bottom Body (22) using 4 M6 x 15 Bolts (B) and 4 M6 Nuts (E).

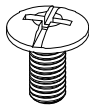



B	E
 X4	 X4

Step 6

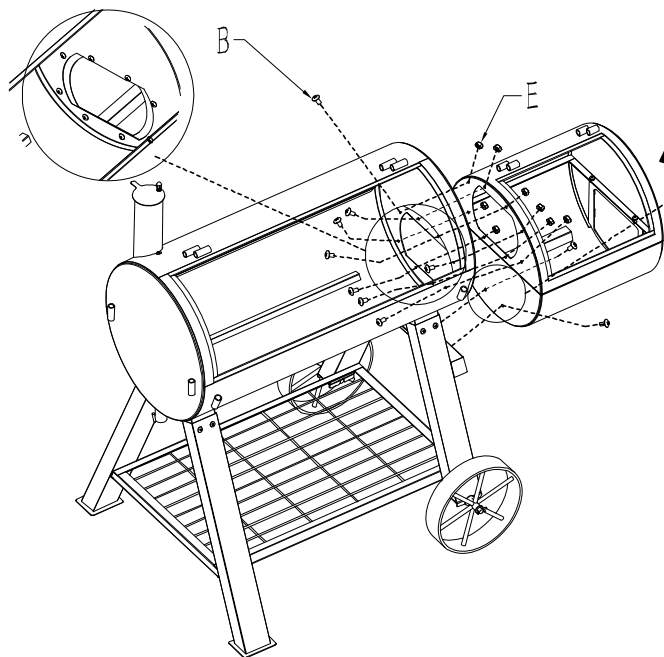
1. Align the Side Grill Body with the Main Grill Body.
2. Secure the Side Grill Body to the Main Grill Body using 10 M6 x 15 Bolts (B) and 8 M6 Nuts (E).



B	E
 X10	 X8

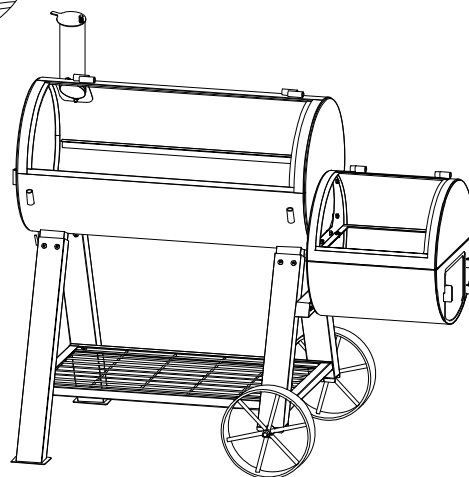



Assembly Instructions & User's Manual

Step 7

1. Attach the two Lid Handles (4) to the Main Grill Lid (5) and the Side Grill Lid (19) using 8 M6 x 15 Bolts (B), 8 M6 Washers (D), and 8 M6 Nuts (E).
2. Remove the pre-installed nut from the Temperature Gauge (3), then attach the Temperature Gauge to the Main Grill Lid (5) using the provided nut.

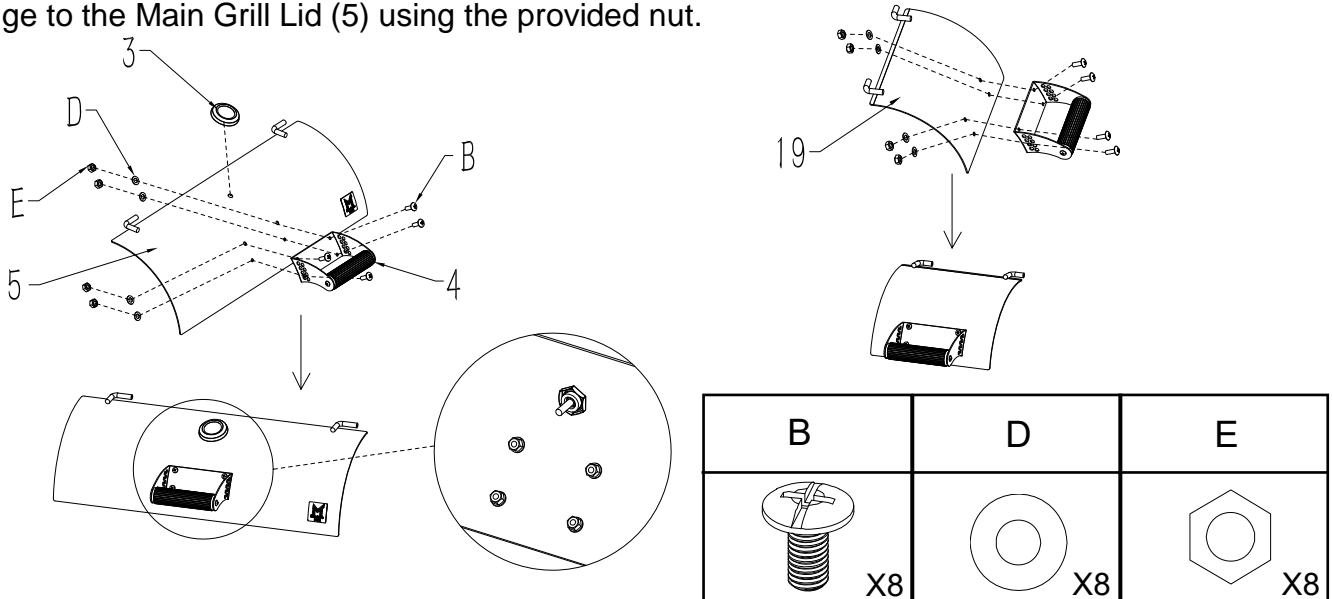

Step 8

1. Attach the two Grill Lids to the corresponding plugs on the Main Grill Body and Side Grill Body using 4 M6 x 15 Bolts (B) and 4 M6 Washers (D).
2. Attach the Side Charcoal Door (23) to the plugs on the Side Grill using 2 M6 x 15 Bolts (B) and 2 M6 Washers (D).

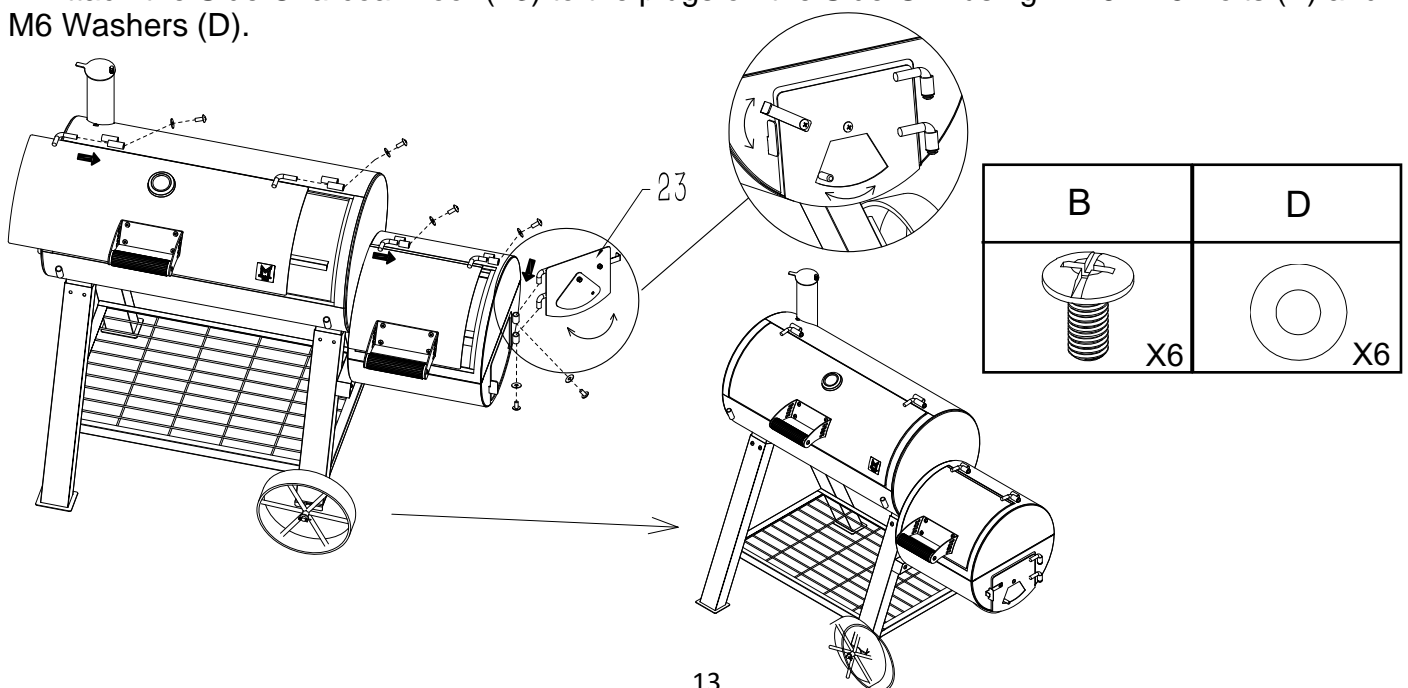



Assembly Instructions & User's Manual

Step 9

1. Attach the Side Shelf (8) and Front Shelf (15) using 4 M6 x 15 Bolts (B) and 4 M6 Washers (D).
2. Hang the Grease Bucket (12) in the position shown in the illustration.

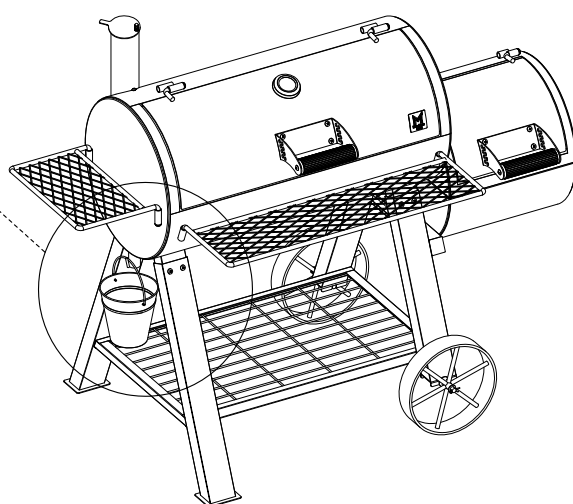
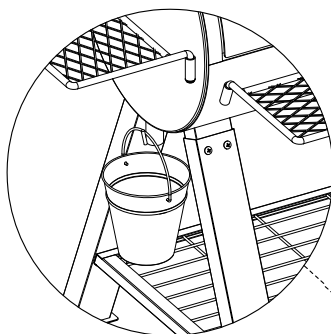
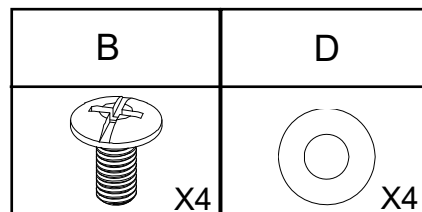
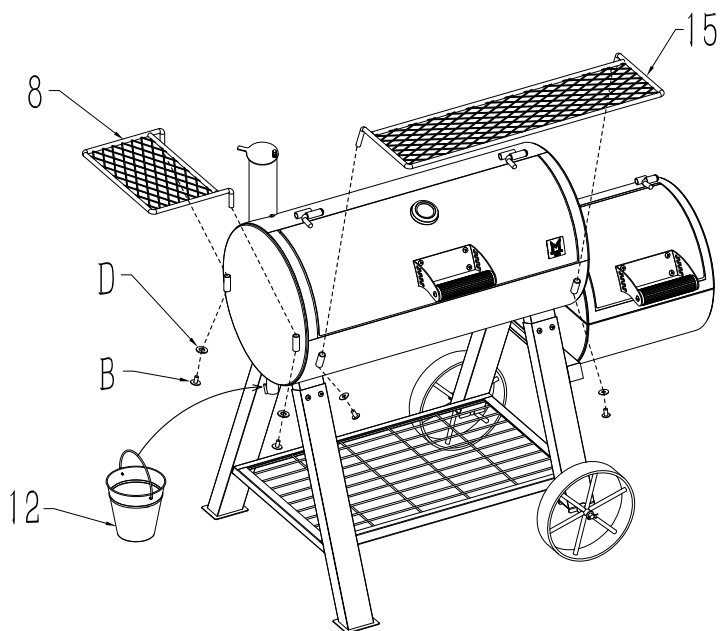



Assembly Instructions & User's Manual

Step 10

1. Place the Main Charcoal Brazier (7) and Main Cooking Grates (6) into the Main Grill Body.
2. Place the Side Charcoal Brazier (21) and Side Cooking Grates (18) into the Side Grill Body.
3. To use the Main Cooking Grate Lifter (24), position as shown in the illustration.

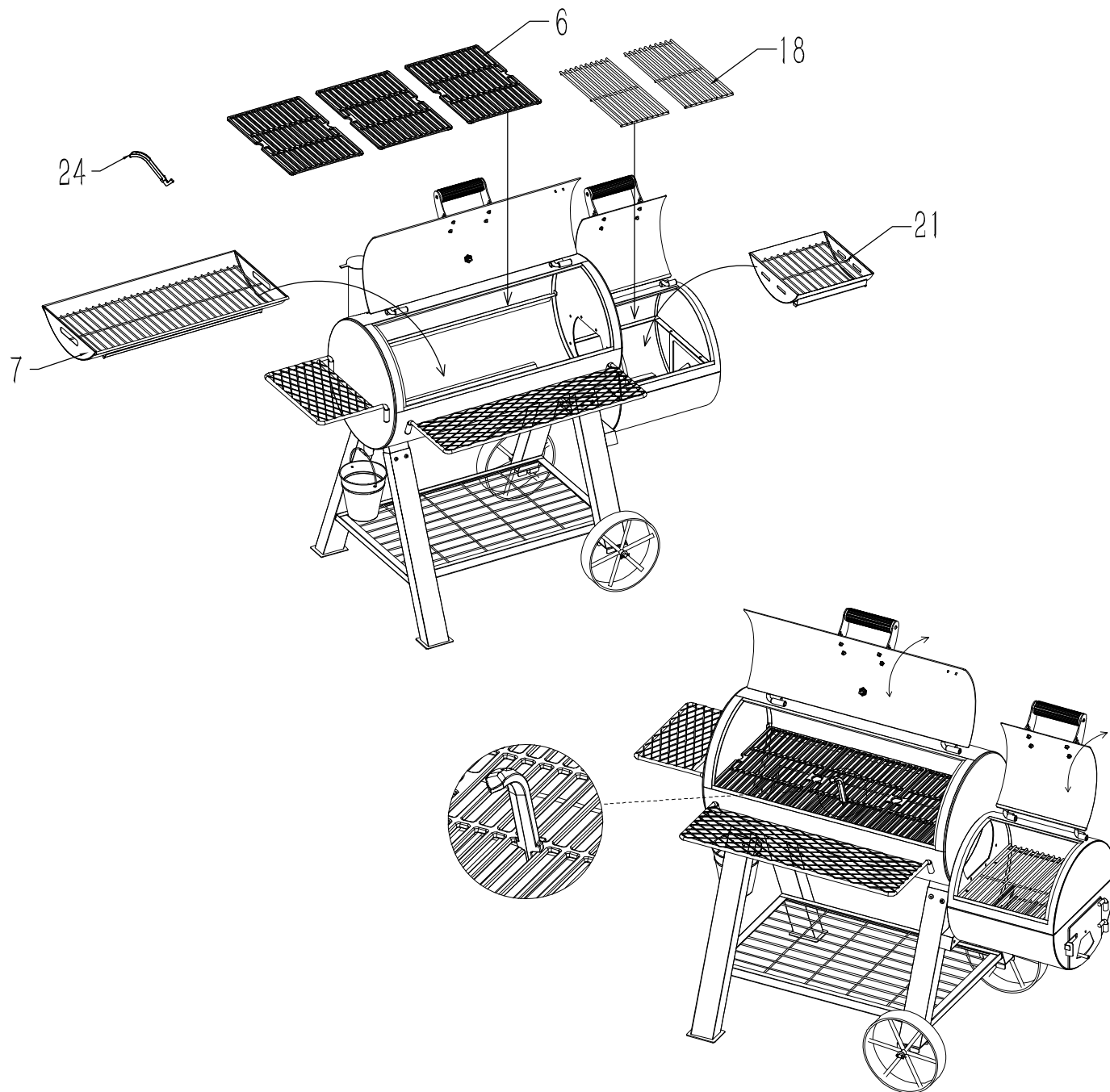



Assembly Instructions & User's Manual

Step 11

1. Once the grill has completely cooled down, cover it with the Grill Cover (25).
2. Adjust the Velcro tabs at the bottom of the cover to tighten it and ensure a secure fit.

IMPORTANT: Always allow the grill to cool completely before covering it to avoid any risk of damage or safety hazards.

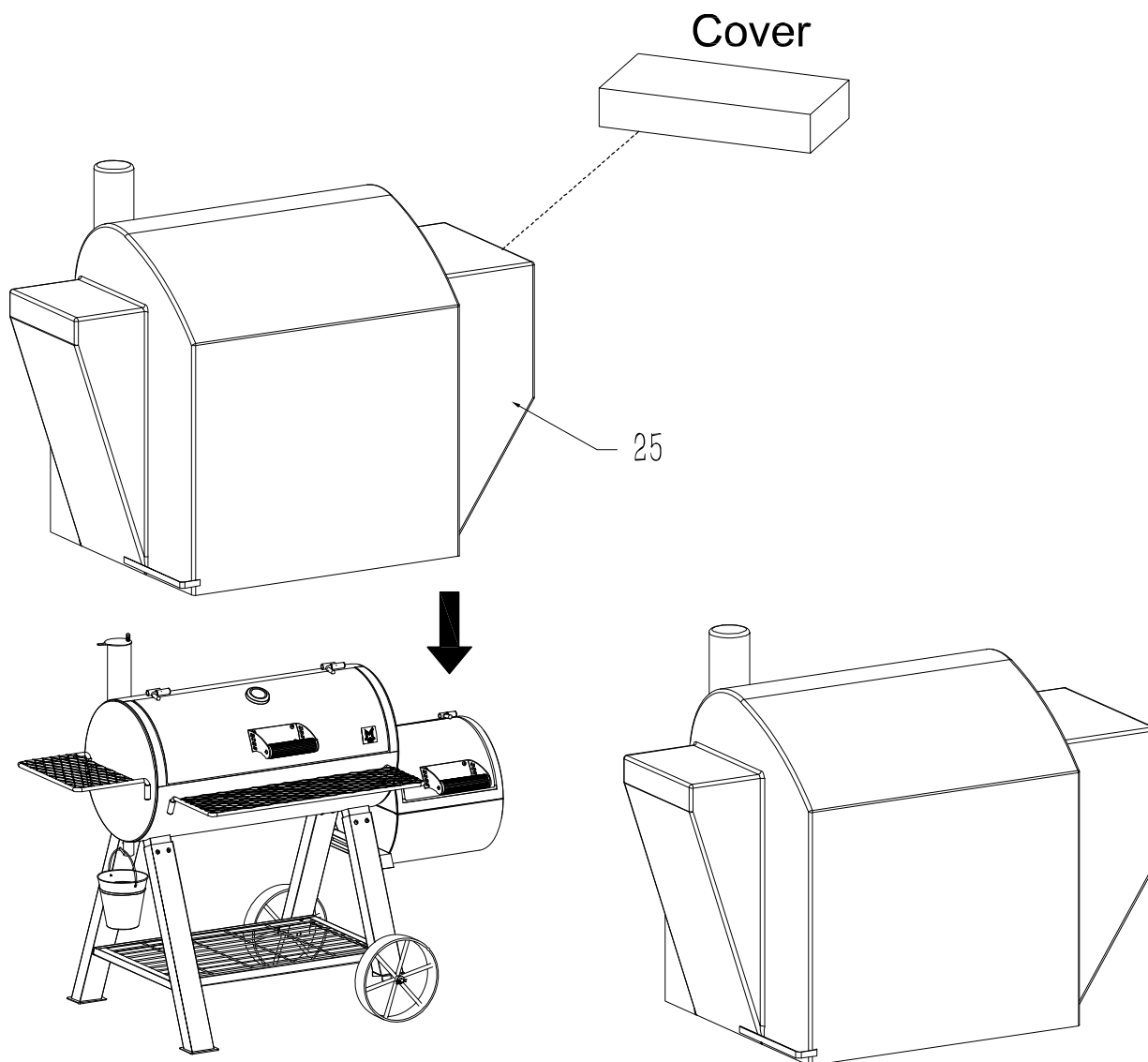

Need Assistance? Visit us at: samsclub.com/membersmarkhelp



Assembly Instructions & User's Manual

Grill Use Safety

⚠ Warning

Please only use the grill outdoors, on a hard, level, non-combustible, stable surface (concrete, ground, etc.), capable of supporting the weight of the grill. Keep away from roof overhang or any combustible material. Never use on wooden or other surfaces that could burn. Place the grill away from open windows or doors to prevent smoke from entering the house. In windy weather, place the grill in an outdoor area that is protected from the wind.

- Do not use grill without charcoal ash tray in place. Do not attempt to remove charcoal ash tray when coals are hot.
- When grill is in use, keep clearance of 36" between the hot grill and any combustible materials, such as bushes, trees, wooden decks, wooden fences, buildings, etc.
- For outdoor use only. Do not operate grill indoors or in an enclosed area.
- For household use only. Do not use this grill for other than its intended purpose.
- Place grill in an area where children and pets cannot come into contact with the unit. Close supervision is necessary when grill is in use.
- NEVER leave a hot grill unattended.
- Grill is hot when in use. DO NOT attempt to move the grill while lit or still hot. DO NOT TOUCH any hot grill surfaces. ALWAYS wear protective gloves or oven mitts.
- DO NOT wear loose clothing or allow hair to come into contact with grill.
- NEVER add pre-soaked charcoal to hot or warm coals or ashes. Dangerous or explosive flare ups could occur and result in bodily harm.
- USE EXTREME CAUTION when adding charcoal and/or wood to the grill while cooking, as charcoal is still hot and can cause burns.
- AVOID INJURY! ALWAYS wear oven mitts or grilling gloves when lifting the lid, adjusting the grates, or in any other way touching the grill while it is hot.
- Lids are heavy, and will be very hot during and after use.
- When opening lid, be sure lid is fully opened and secure to prevent lid from closing unexpectedly.
- Close lid to suffocate flame.
- NEVER place more than 8 lb (3.6 kg) on any shelf. DO NOT lean on any shelf.
- NEVER raise or lower the charcoal grate when smoking with water as hot water may splash onto the coals creating a burst of steam and hot ash.
- When grilling, grease from food may drip onto the charcoal and cause a grease fire. If this happens close the lid and dampers to suffocate the flame. NEVER use water to extinguish a grease fire.
- Keep hands, face, and body a safe distance from the grill when opening the lid. Flare-ups may occur when flames or hot coals encounter increased airflow.



Assembly Instructions & User's Manual

After Use Safety

- We advise that a fire extinguisher be on hand. Refer to your local authority to determine proper size and type of fire extinguisher.
- ALWAYS allow grill and all components to cool completely before handling.
- DO NOT remove ashes or used coals from the grill until they are fully extinguished.
- To extinguish charcoal, close all vents and place lid on grill until coals are completely out.
- NEVER leave coals and ash unattended in the grill. All extinguished coals and ash must be removed and carefully placed in a non-combustible metal container. Saturate coals and ash with water and allow them to remain in the metal container for 24 hours before disposing.
- Keep extinguished coals and ash safely away from combustible structures and materials.
- Spray or douse the surfaces under and around the grill with water until completely wet to extinguish any ashes, coals, or embers that may have fallen during grilling or cleaning.
- After each use, clean the grill thoroughly and apply a light coat of vegetable oil to prevent rusting. Cover the grill to protect it from excessive rusting.
- Use caution when lifting or moving grill to prevent strains and back injuries.
- Store the grill in a dry location out of reach of children and pets when not in use.
- Do not attempt to service grill other than normal maintenance as explained in 'After Use Safety' and proper 'Care & Use Instructions' sections in this manual.
- Properly dispose of all packaging material.

Failure to adhere to safety warning and guidelines in this manual could result in bodily injury or property damage. Save this manual for future reference.

Troubleshooting

Problem	Possible Cause	Prevention / Solution
Cooking temperature not even	Charcoal placement is not even	Spread the charcoal evenly over the charcoal grid.
Temperature too low for cooking	Insufficient charcoal quantity may not be enough / not enough air for burning charcoal	Add more charcoal/ open the damper.
Flame too strong	Too much charcoal	Close the dampers and close the lid for 15-30 minutes OR until the flame gets smaller.
Flare-up during cooking	Too much grease falls on the burning charcoal	Remove the greasy food and close the lid.
Cast iron cooking grates get rusted	The cast iron cooking grate surface was not sufficiently coated with vegetable oil.	Use grill brush to clean the rusted area, wash it thoroughly with water. Then lightly coat the grates with vegetable oil or vegetable oil spray.



Assembly Instructions & User's Manual

Care & Use Instructions

Care

- Use a soft, clean cloth that will not scratch the surface when cleaning.
- Wash cooking grids and charcoal grates with hot, soapy water. Rinse well and dry completely with a towel. NEVER allow grates to drip dry, or dry in a dishwasher, as rusting may occur.
- After washing and drying, lightly coat grates and grids with vegetable oil or vegetable oil spray.
- Clean the inside and outside of the grill by wiping it with a damp cloth. Apply a light coat of vegetable oil or vegetable oil spray to the interior surfaces to prevent rusting.
- If rust appears on the outside of your grill, clean and buff the affected area with steel wool or a fine grit emery cloth. Touch up spots with a good quality high-temperature, rust resistant paint.
- NEVER APPLY PAINT TO THE INTERIOR SURFACE. Doing so could cause a fire resulting in serious bodily harm or property damage.
- If rust appears on the interior surface of you grill, clean and buff the affected area with steel wool or a fine-grit emery cloth. Coat the interior lightly with vegetable oil or vegetable oil spray.
- To protect your grill from excessive rust, the unit must be properly cured and covered at all times when not in use.

Operating Instructions

Only use high grade charcoal briquettes, lump charcoal, cooking wood or charcoal/wood mixtures. Wood chips and wood chunks may be used for a more robust flavor. Wood chips are available in a variety of flavors

Adding Charcoal / Wood During Cooking

Step1: Stand back and carefully open grill lid. Use caution since flames can flare up when fresh air suddenly comes in contact with fire.

Step2: Wearing oven mitts/gloves, lift up the cooking grid an place it on a clean and non-combustible surface. DO NOT touch the grate or grid by hand.

Step3: Stand back a safe distance and use long cooking tongs to lightly brush aside ashes on hot coals. Use cooking tongs to add charcoal and/or wood to charcoal grid. Be careful not to stir up ashes and sparks. If necessary, use your charcoal chimney stater to light additional charcoal and/or wood and add them to existing fire.

Never add charcoal lighting fluid to hot or even warm coals as flashback may occur causing server burns.

Step4. When charcoal is burning strong again, wear oven mitts/gloves and carefully return charcoal grates into the grill. Extinguish any hot ashes, coals or embers which may have fallen off from the grill to beneath and around the grill.

Direct Grilling



Assembly Instructions & User's Manual

Grilling directly over hot coals is ideal for searing in juices and grilling food requiring less than 25 minutes of grilling time, such as steaks, hamburgers, hot dogs, chicken parts, vegetables and fruit.

- Open lid and remove cooking grates.
- Load and light charcoal per 'Charcoal Lighting Instructions' section. Leave lid open.
- While wearing hand protection, carefully spread hot coals evenly across charcoal grid with a long handle tool.
- While wearing hand protection, replace the cooking grates, close the lid and allow the charcoal grill to preheat.
- While wearing hand protection, open the lid and place food onto cooking grates above the hot coals with a long handle tool.
- With lid open or closed, cook until desired internal food temperatures are achieved.
- NOTE: If additional briquettes are needed, remove food from cooking grates and while wearing hand protection remove the cooking grates and place additional briquettes without disturbing the hot coals. Carefully replace the cooking grates and food.
- Allow charcoal to burn out by closing lid and all vents.

For more tips on direct grilling please see 'Tips for Better Cookouts and Longer Grill Life' section.

Indirect Grilling

Not cooking directly over hot coals is ideal for slow cooking and grilling foods requiring more than 25 minutes such as most roasts, loins, chops, whole chickens, turkey, fish and baked goods.

- Open lid and remove cooking grates.
- Load and light charcoal per "Charcoal Lighting Instructions" section. Leave lid open.
- While wearing hand protection, carefully spread hot coals to the outside of charcoal grid with a long handle tool.
- While wearing hand protection, replace cooking grates, close lid and allow charcoal grill to preheat.
- While wearing hand protection open the lid. Use a long-handled tool to place the food onto the cooking grates above the area without hot coals.
- With lid closed, cook until desired internal food temperatures are achieved.
- NOTE: If additional briquettes are needed, remove food from cooking grates, and while wearing hand protection, remove the cooking grates and place additional briquettes without disturbing the hot coals.

Tips for Better Cookouts and Longer Grill Life

- To reduce flare-ups, keep the charcoal grill clean, use lean cuts of meat (or trim fat) and avoid cooking at very high temperatures.
- Place delicate foods like fish and vegetables in aluminum foil pouches and indirect-grill or place on upper cooking levels (warming rack), if available.
- To avoid losing natural juices, use long-handled tongs or spatulas instead of forks and turn foods over just once during cooking.



Assembly Instructions & User's Manual

- When indirect-grilling roasts and larger cuts of meat, place meat onto a roasting rack inside a heavy gauge metal pan.
- Try water pans to reduce flare-ups and cook juicier meats. Before starting coals remove cooking grates and place a heavy-duty shallow pan directly on charcoal grid. Fill half way with water, fruit juices or other flavored liquids. Place coals around grid per "Charcoal Lighting Instructions", replace cooking grates and position food over the loaded pan.
- Enhance food flavors by using wood chips in smoker boxes or aluminum foil pouches. Follow the wood manufacturer's instructions.
- Rotisseries, charcoal grill baskets, vertical poultry holders and other accessories can enhance your experiences, reduce cooking times and aid in clean-up.
- Clean cooking grates and racks after every use with a quality charcoal grill brush designed for your grid material. Wear protective hand gear and gently remove the build-up while grids are hot.
- Allow charcoal grill to fully cool after every use. Then protect clean cooking grates with a light coat of vegetable oil or vegetable spray, clean out all ashes, wipe outside surfaces with a suitable kitchen cleaner and protect surfaces with a quality cover that properly fits your grill.

Controlling Flare-ups

Flare-ups are a part of cooking meats on a charcoal grill and adds to the unique flavor of grilling. Excessive flare-ups can over cook your food and cause a dangerous situation for you and your charcoal grill. Excessive flare-ups are result from the build-up of grease in the bottom of your charcoal grill.

If grease fire occurs, close the lid until the grease burns out. Use caution when opening the lid as sudden flare-ups may occur.

If excessive flare-ups occur, DO NOT pour water onto the flames.

Minimize Flare-ups

- Trim excess fat from meats prior to cooking.
- Cook high fat content meats indirectly.
- Ensure that your charcoal grill is on a hard, level, non-combustible surface.

Need Assistance? Visit us at: samsclub.com/membersmarkhelp



Assembly Instructions & User's Manual

Limited Warranty Information

Limited Warranty

This product is covered by the Sam's Club Member Satisfaction Guarantee. Please visit samsclub.com for more information.

Manufacturer warrants this product to be free from defects in workmanship and materials for period of 1 year from the date of purchase, PROVIDED claims are submitted, in writing, with proof of purchase. If any part of this item fails because of a manufacturing defect within the Limited Warranty Period, manufacturer offers to replace such part(s) provided that such part(s) have not been improperly repaired, altered, or tampered with or subject to misuse, abuse or exposed to corrosive conditions. This Limited Warranty is, however, subject to certain limitations, exclusions, time limits and exceptions (Hereinafter 'Conditions') as listed below. Read these Conditions carefully.

This Limited Warranty shall be limited to the replacement or repair of any part(s) which manufacturer determines, after reasonable examination, to have been defective at the time of manufacturing and manufacturer's obligation(s) shall be limited to replacement, if any, of defective part(s) which shall be shipped at original purchaser's expense to the original purchaser's designated shipping address.

This warranty excludes normal wear & tear such as paint loss, discoloration and rust on the product and its parts or components, and any damage arising from any of the following: negligent use or misuse of the product, use contrary to this User's Manual, or alteration by anyone other.

This Limited Warranty is given to the covers the original purchaser only and such coverage terminates 1 year from the date of purchase.

All warranty coverage is void if this grill is ever used for commercial or rental purposes.

The warranty period of 1 year shall not be extended or renewed by the repair or replacement of parts or compensation for the product.

DAMAGE LIMITATION WARNING: in no event shall manufacturer be liable for any incidental or consequential damages, including (but not limited to) loss of use of the product, loss of time, inconvenience, expenses for travel, transportation lodging expenses, loss by damage to personal property or loss of income, profits or revenue.

Manufacturer's obligation: manufacturer's liability shall be limited to the delivery of goods, merchantable product and, if necessary, the repair or replacement, at manufacturer's option, of any defective part of unit.

Transfer limitations: This Limited Warranty is not assignable or transferable. It covers only the original purchaser.

Reserved right to change: Manufacturer reserves the right to make changes or improvements to products it produces in the future without imposing on itself any obligations to install the same improvements in the products it has previously manufactured.

This Limited Warranty gives the original purchaser specific legal rights but there may be other rights which vary by jurisdiction.

If you have any questions regarding the warranty or spare / replacement parts, please call our toll-free number 1-866-273-2284, or email us: customerservice@sumxing.com

NOTE: Please consider recycling all applicable packaging material.



Assembly Instructions & User's Manual

Distributed by Sam's West Inc.
2101 SE Simple Savings Dr.
Bentonville, Arkansas 72716-0745
Made in China

Need Assistance? Visit us at: samsclub.com/membersmarkhelp