

airLIFT Electric Tempered Glass Height Adjustable Desk (Model No. OFF65991, OFF65992)



*NOTE: We recommend using TWO people to assemble the desk.



Error Code List

Code	Meaning	Action
SC0	Self-Check Fail - Standby Mode Error	Re-plug in the power cable. If the alert does not clear, please contact customer service.
SC1	Self-Check Fail - Main Power Error	Re-plug in the power cable. If the alert does not clear, please contact customer service.
SC2	Self-Check Fail - Save Memory Error	Re-plug in the power cable. If the alert does not clear, please contact customer service.
SC3	Self-Check Fail - Sensor Error	Re-plug in the power cable. If the alert does not clear, please contact customer service.
R-2	Table Tilt Alert	The desk will run in the opposite direction for about 2" automatically, then the alert will clear.
R-3	Sync Failure	Reset the desk, refer to page 10 for instructions on how to reset the desk.
HOT	Overheat Protection	Let the motors cool down for 18 minutes.
R-5	Control system malfunction	Check the connection of the power cable and LED control panel, refer to image on page 8.
R-6	Voltage irregularity	Contact customer service.
RST	Not reset completely	Reset the desk, refer to page 10 for instructions on how to reset the desk.
EX0	Driver Short-Circuit	Re-plug in the power supply. If the alert does not clear, contact customer service.
EX1	Over-Load Protection	Remove some weight from the desk, then the alert will clear after 20 seconds.
EX2	Motor Phase Failure	Check the connection of motor cable, refer to image on page 8.
EX3	Moving Direction Error	Please contact customer service.
EX4	Anti-collision	The desk will run in the opposite direction for about 2" automatically, then the alert will clear.
EX5	Motor Stalling Alarm	Contact customer service.
EX6	Motor wire not connected	Check the connection between motor cable and the LED control panel, refer to image on page 8.
EX7	Mechanical Malfunction	Contact customer service.



Get help with assembly and report damaged or missing parts.

Email: Support@SevilleClassics.com

Telephone: 1 (800) 323-5565

Hours (M-F): 8:30 AM - 4:30 PM (PST)



ASSEMBLY INSTRUCTIONS

**airLIFT Electric Tempered Glass Height Adjustable Desk
Model No. OFF65991 (Black), OFF65992 (White)**

48 in. W x 24 in. D x 28 ~ 47in. H (1.21m x 0.61 m x 0.71 ~ 1.19 m)

WARNING: Desk Maximum Loading Capacity is 176 lbs (80 kgs)

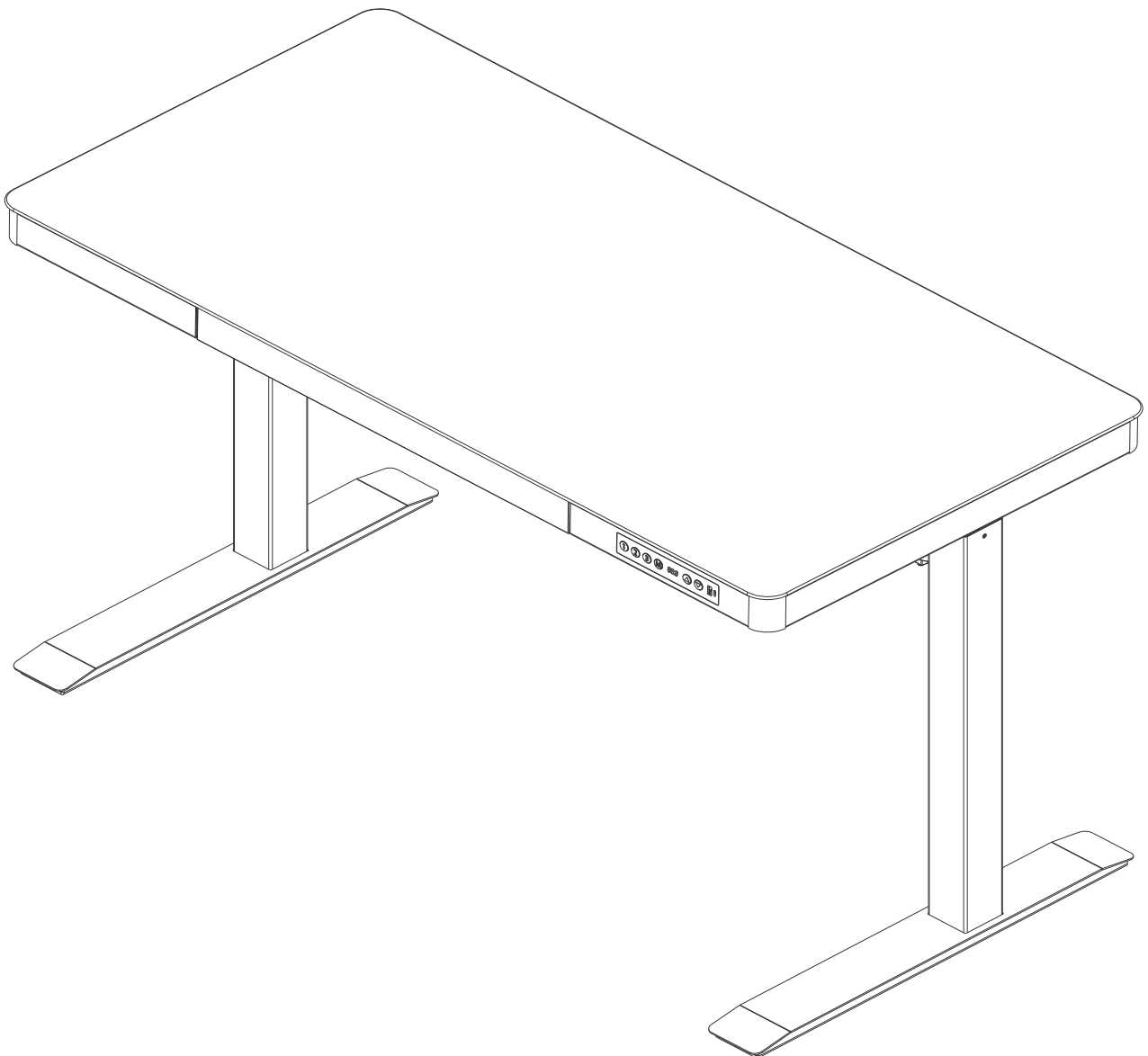

**USER MANUAL
KEEP FOR FUTURE REFERENCE.**



Safety Instructions



FAILURE TO COMPLY WITH OR OBSERVE ALL ASSEMBLY, SAFETY AND OPERATING INSTRUCTIONS AND WARNINGS REGARDING THE USE OF THIS PRODUCT MAY RESULT IN SERIOUS BODILY INJURY



- Read and understand this manual before attempting to install or operate.
- Assure that everyone who uses this product is informed of the contents of this manual. This is the responsibility of the Purchaser.
- Not intended for use by young children or for those persons who require supervision.
- Do not open any of the components – legs or LED Control Panel. There is a risk of electric shock.
- Assemble desk on a flat and level surface.

Use & Liability

Safe use of this product is possible only when the operating instructions are read completely and the instructions contained are strictly observed. Persons who do not have the necessary experience or knowledge of this product must not use the product. Persons with reduced physical or mental abilities should not use this product, unless they are under supervision or they have been thoroughly instructed in the use of the apparatus by a person who is responsible for the safety of these persons. Children should be closely supervised to ensure that they do not play with this product.

Before You Begin

Layout all components and hardware. Visually examine and make sure components are free of damage. If there is visual damage to any component, it must not be installed.

Two people are needed to turn or move the desk and some of its components. When moving or turning the assembled desk, grab the legs, not the desk top.

Make sure to assemble on a soft and non-abrasive surface to avoid scratches.

Check all connections and cables. Make sure the desk is connected to a power outlet.

If the LED Control Panel makes unusual noises or emits an odor, switch power off immediately.

The desk MUST be RESET before first use.



Read the RESET portion prior to operation (page 10).



Get help with assembly and report damaged or missing parts.

Email: Support@SevilleClassics.com

Telephone: 1 (800) 323-5565

Hours (M-F): 8:30 AM - 4:30 PM (PST)

Quick Setup Diagram

Setup should take about 15 minutes to complete. All required tools are included. Keep the top frame in the box during assembly to protect it from scratches.

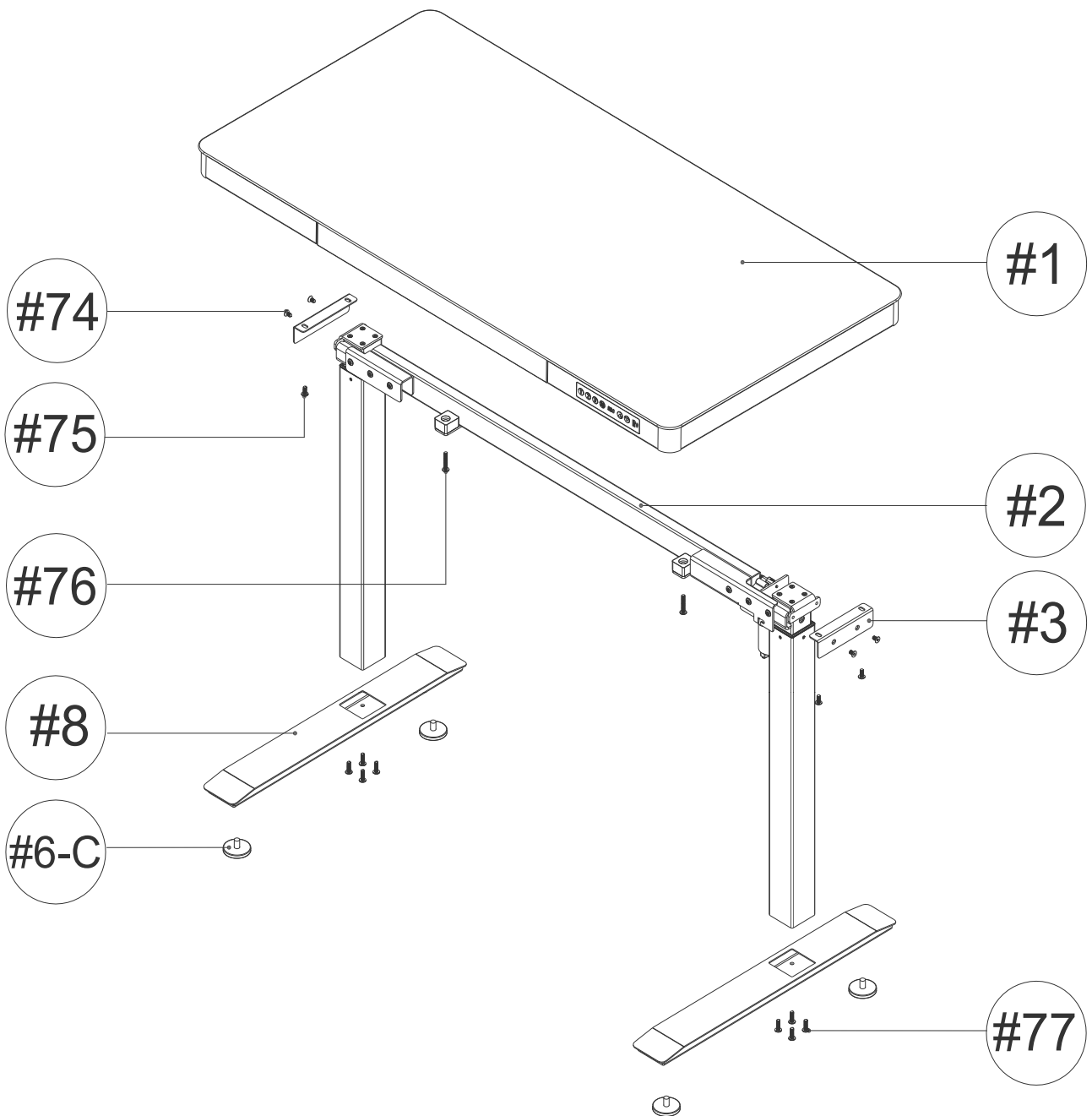

Get help with assembly and report damaged or missing parts.

Email: Support@SevilleClassics.com

Telephone: 1 (800) 323-5565

Hours (M-F): 8:30 AM - 4:30 PM (PST)

PARTS LIST

Please check the parts carefully according to the parts list. If you are missing any parts, please contact our customer service department.

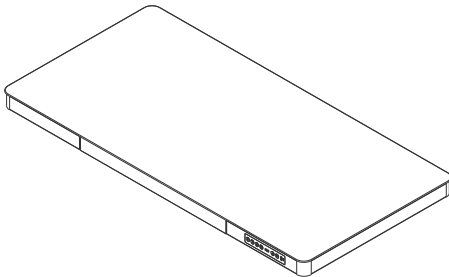
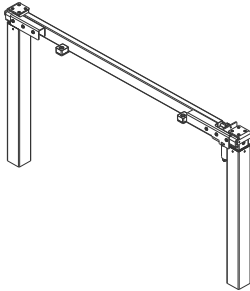
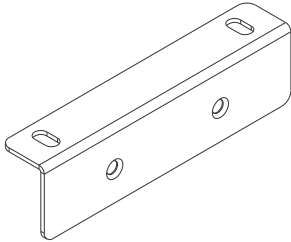
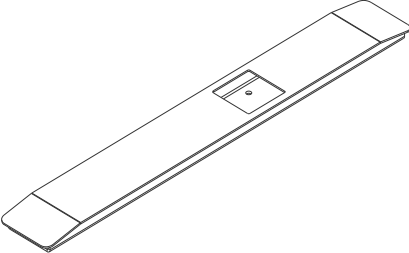
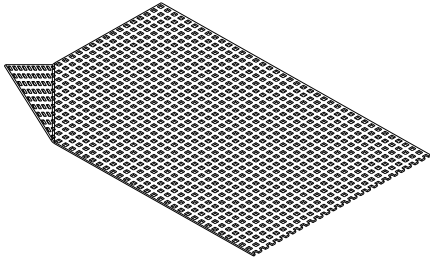
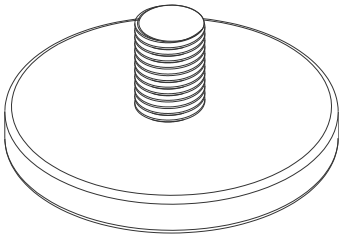
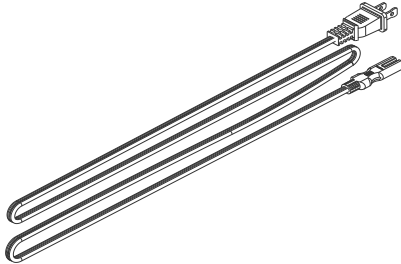
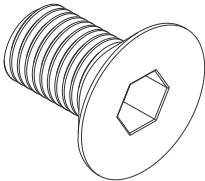
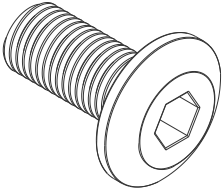
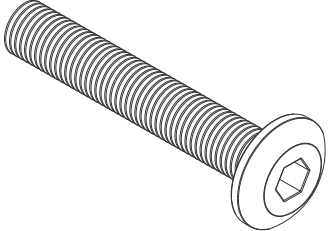
	
<p>(#1) Top Frame x 1 PC</p>	<p>(#2) Legs/Beam x 1 PC</p>
	
<p>(#3) Bracket x 2 PCS</p>	<p>(#8) Feet x 2 PCS</p>
	
<p>(#7-A) Drawer Mat x 1 PC</p>	<p>(#6-C) Leveling feet x 4 PCS</p>
	
<p>(#11) Power Cable x 1 PC</p>	<p>(#74) Screw (M6 x 10L) x 4 PCS</p>
	
<p>(#75) Screw (M6 x 14L) x 4 PCS</p>	<p>(#76) Screw (M6 x 35L) x 2 PCS</p>



Get help with assembly and report damaged or missing parts.

Email: Support@SevilleClassics.com

Telephone: 1 (800) 323-5565

Hours (M-F): 8:30 AM - 4:30 PM (PST)

PARTS LIST

Please check the parts carefully according to the parts list. If you are missing any parts, please contact our customer service department.

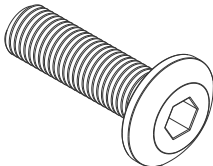
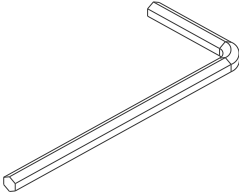
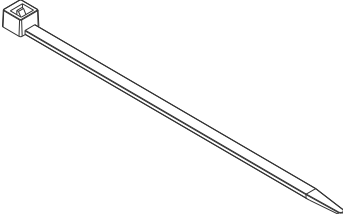
	
(#77) Screw (M6 x 20L) x 8 PCS	(#78) Hex Key x 1 PC
	
(#73) Cable Tie x 2 PCS	



Get help with assembly and report damaged or missing parts.

Email: Support@SevilleClassics.com

Telephone: 1 (800) 323-5565

Hours (M-F): 8:30 AM - 4:30 PM (PST)

airLIFT Electric Tempered Glass Height Adjustable Desk (Model No. OFF65991, OFF65992)



*NOTE: We recommend using TWO people to assemble the desk.



Step 1: Remove Legs/Beam (#2) from the box

Take out the Legs/Beam (#2) and move to a nearby worktable. Note that the center beam will be connected to the base of the Top Frame (#1) later in this guide. The side that features the motor is the right side.

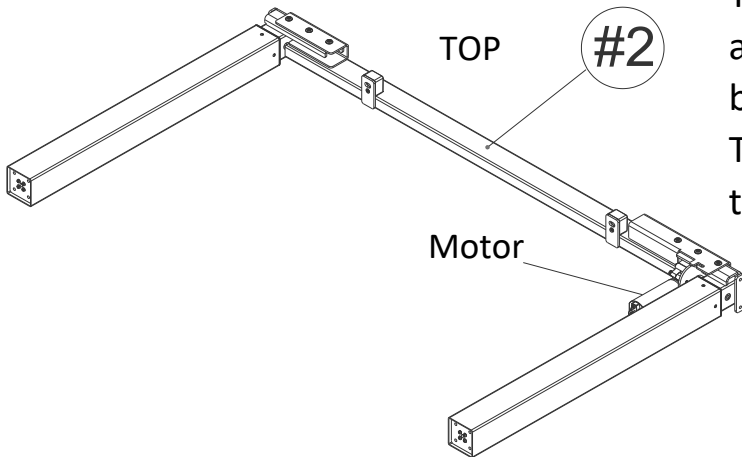

Step 2: Install Bracket (#3)

Place bracket (#3) to each end of the legs located on the Legs/Beam (#2), align the screw holes and use 4 pieces of the M6 x 10L screw (#74) using the Hex Key (#78) to tighten. As displayed in the left image.

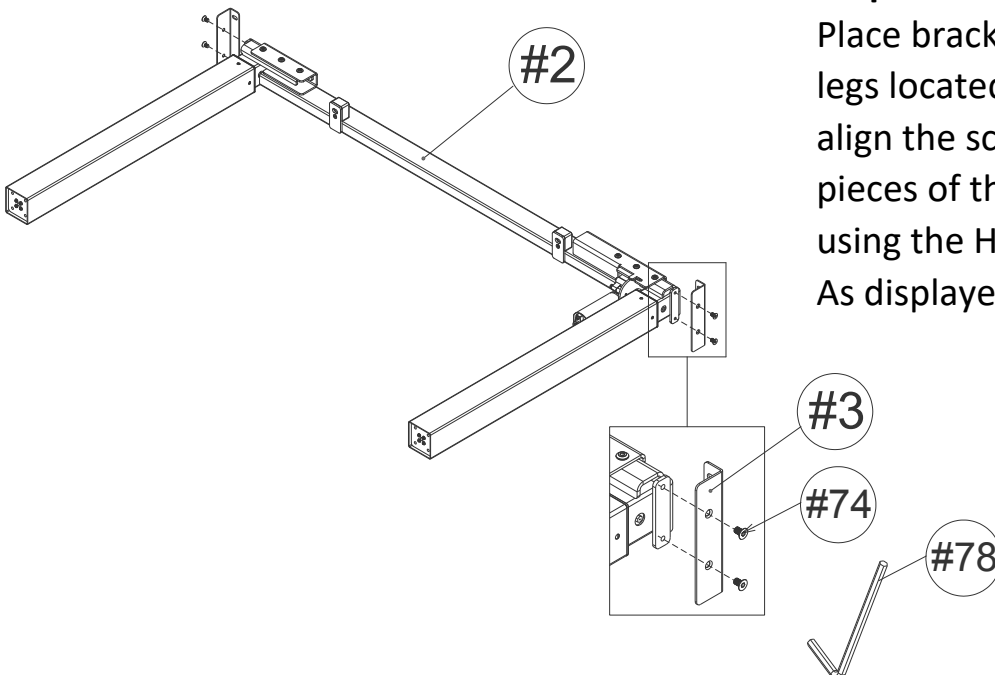

Get help with assembly and report damaged or missing parts.

Email: Support@SevilleClassics.com

Telephone: 1 (800) 323-5565

Hours (M-F): 8:30 AM - 4:30 PM (PST)

airLIFT Electric Tempered Glass Height Adjustable Desk (Model No. OFF65991, OFF65992)



*NOTE: We recommend using TWO people to assemble the desk.



Step 3: Remove Top Frame (#1) from Box

Open the package, take out the Top Frame (#1) from the box, this item is heavy so we recommend 2 people for this step. Identify the front side from the back, note the drawer will be facing the front.

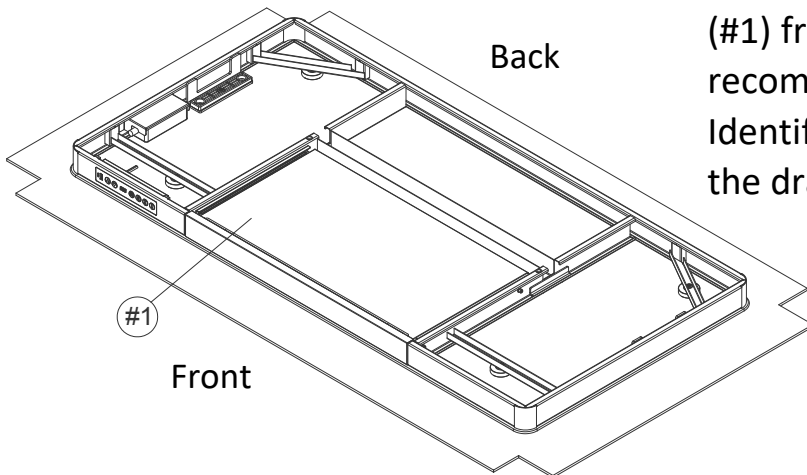

Step 4: Install Leg/Beam (#2) on the Top frame (#1).

1. Place the Leg/Beam (#2) on the Top Frame (#1), and align the screw holes of the center beam to the corresponding ones, using 2 pieces M6 x 35L screws (#76) to tighten. DO NOT fully tighten the screws yet.

2. Align the screw holes on the end of each side of the Leg/Beam (#2) with Top Frame (#1), use 4 pieces M6 x 14L screws (#75) to tighten. Tighten all screws fully. Refer to the image on the left.

Note: we recommend using 2 people for this step.

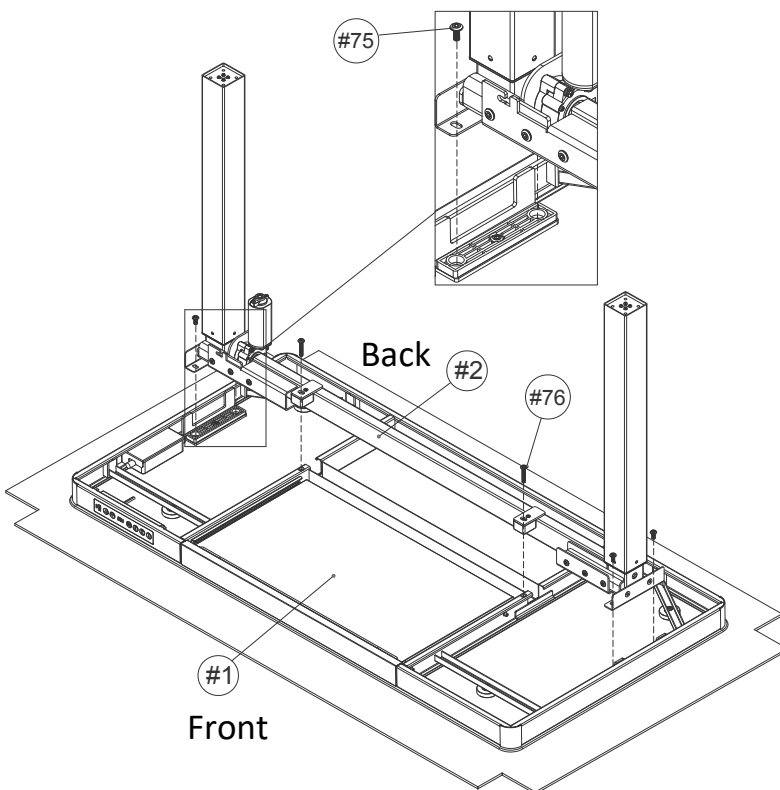

Get help with assembly and report damaged or missing parts.

Email: Support@SevilleClassics.com

Telephone: 1 (800) 323-5565

Hours (M-F): 8:30 AM - 4:30 PM (PST)

airLIFT Electric Tempered Glass Height Adjustable Desk (Model No. OFF65991, OFF65992)



*NOTE: We recommend using TWO people to assemble the desk.

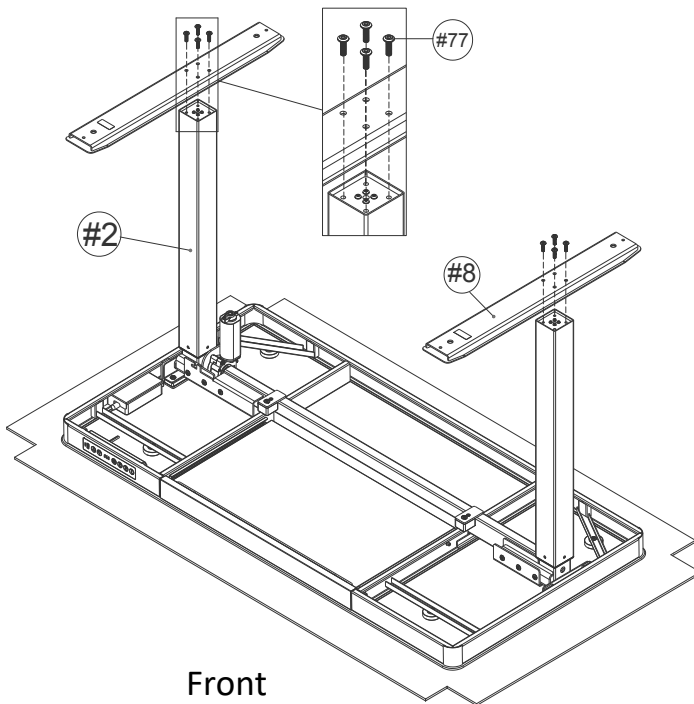

Step 5: Install the Feet (#8)

Use 8 pieces M6 x 20L screws (#77) to install the Feet (#8) on the Leg/Beam (#2).

Note: Please refer to the label on both feet to identify the front side of each foot.

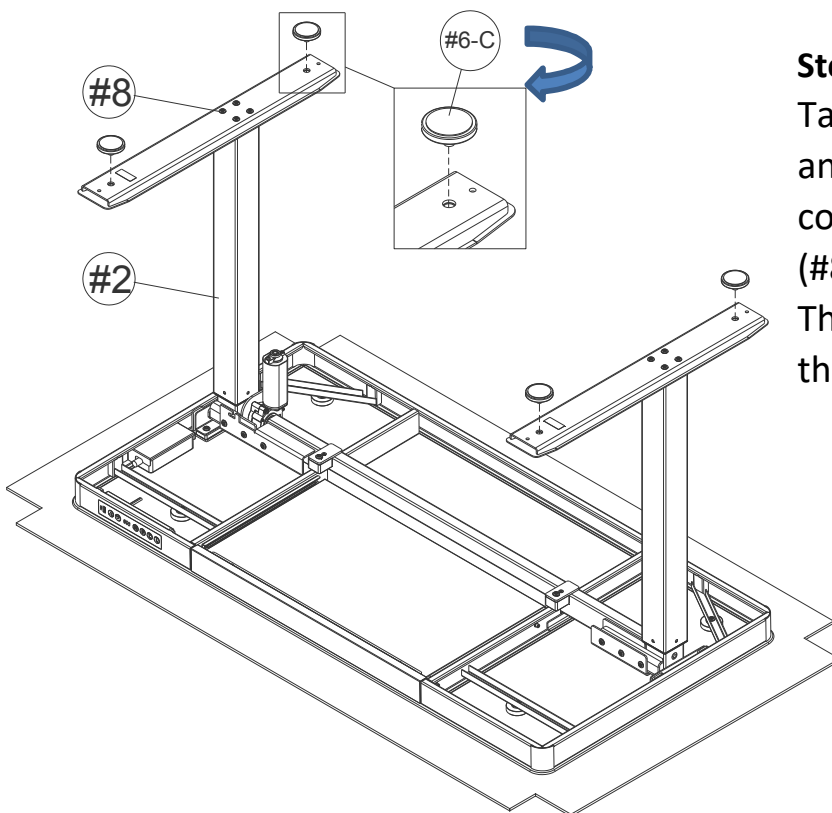

Step 6: Install the Leveling Feet (#6-C).

Take 4 pieces of Leveling Feet (#6-C) and place 2 pieces on each corresponding location on the Feet (#8).

Then fasten them in place by turning them in a clockwise rotation.



Get help with assembly and report damaged or missing parts.

Email: Support@SevilleClassics.com

Telephone: 1 (800) 323-5565

Hours (M-F): 8:30 AM - 4:30 PM (PST)

airLIFT Electric Tempered Glass Height Adjustable Desk (Model No. OFF65991, OFF65992)



*NOTE: We recommend using TWO people to assemble the desk.

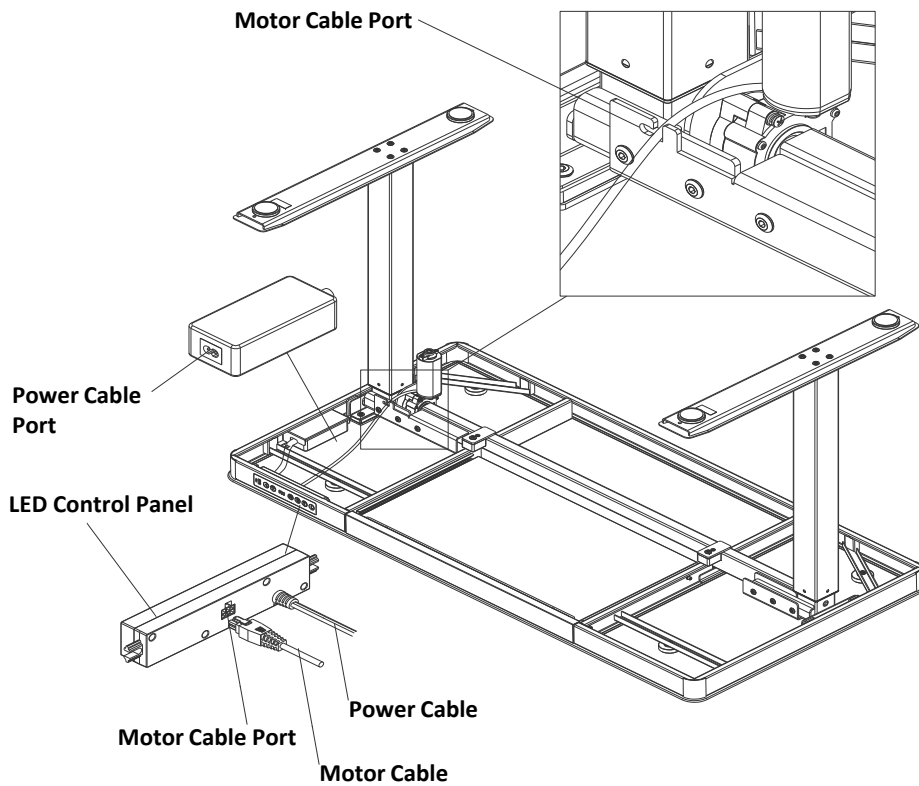

Step 7: Connect Motor Cable

Plug in the Motor Cable from leg beam to the LED Control Panel as displayed in left figure.

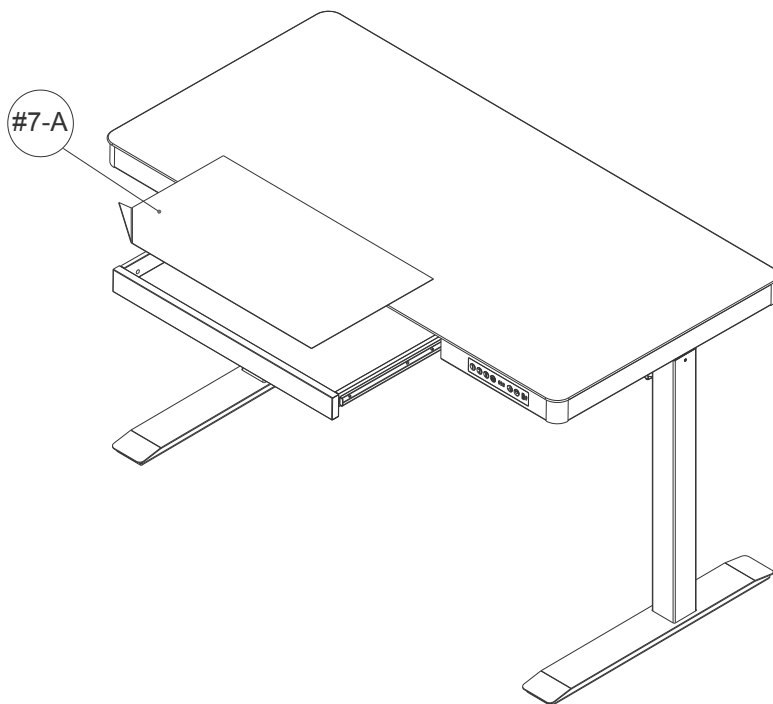

Step 8: Insert Drawer Mat (#7-A)

Using 2 people flip the desk back over on its legs.

Place the drawer mat (#7-A) inside the drawer compartment.



Get help with assembly and report damaged or missing parts.

Email: Support@SevilleClassics.com

Telephone: 1 (800) 323-5565

Hours (M-F): 8:30 AM - 4:30 PM (PST)

airLIFT Electric Tempered Glass Height Adjustable Desk (Model No. OFF65991, OFF65992)



*NOTE: We recommend using TWO people to assemble the desk.



Note: Desk must be RESET before the first use.

LED Control Panel

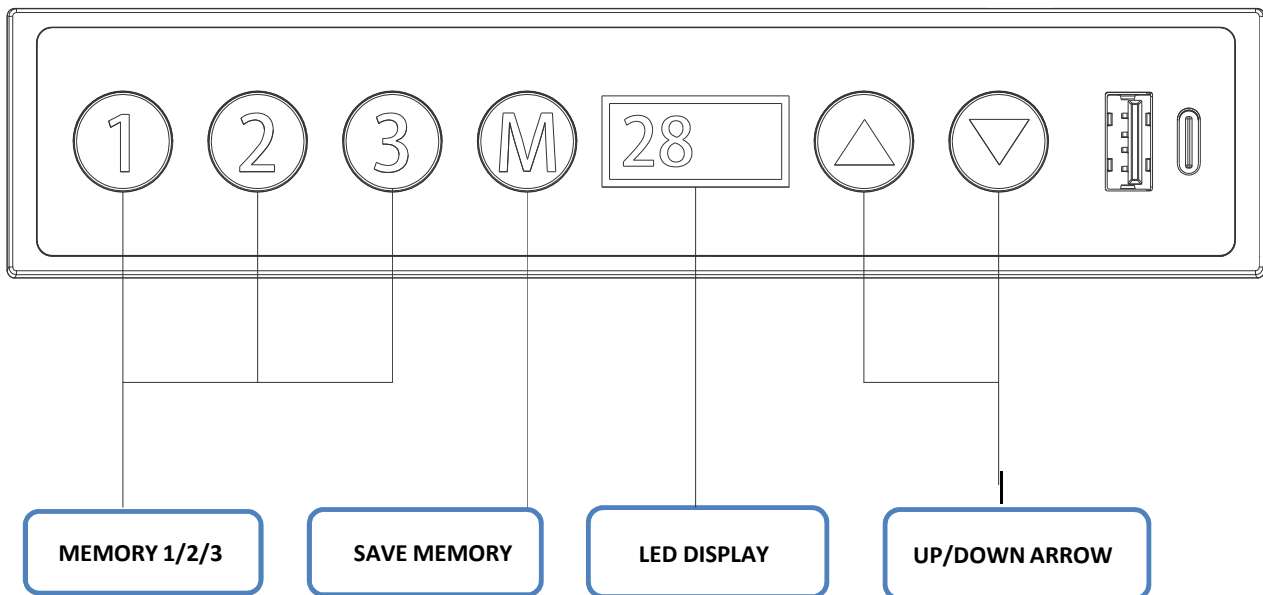

Power ON the desk:

When the desk is plugged in, you will hear a "Beep" sound, then the LED control panel will show the current height of the desk.



Get help with assembly and report damaged or missing parts.

Email: Support@SevilleClassics.com

Telephone: 1 (800) 323-5565

Hours (M-F): 8:30 AM - 4:30 PM (PST)

airLIFT Electric Tempered Glass Height Adjustable Desk (Model No. OFF65991, OFF65992)



*NOTE: We recommend using TWO people to assemble the desk.





Post Setup Quick Start Instructions

How to Reset

Press and HOLD the  button until the unit reaches the lowest height. Continue to press and HOLD for about 5 seconds until you see a number (ie. 28) on the display AFTER it shows "rst" and makes a "beep-beep" sound, then release.





How to Adjust the Height

Press and HOLD either the  or  to adjust to your desired height of the desk.

How to Save the Height in Memory

There are 3 available memory heights you can save - 1, 2 & 3. Adjust the desk to your desired height and press the "M" button to display "S-". While "S" is flashing, select any of 1, 2 or 3 number button. When a memory is saved, you will hear "beep-beep" sound. By repeating the same steps, you can save or override an old saved memory with a new height.

How to Lock/Unlock the LED Control Panel

First adjust the desk height to your desired lock height. Then press and HOLD the  and  together for about 5 seconds until "Loc" is displayed. At this moment, the LED Control Panel is locked and the desk height can't be adjusted. In order to unlock, press and HOLD the  and  buttons together for about 5 seconds until a number (previously locked height) is displayed.

USB Usage Instructions

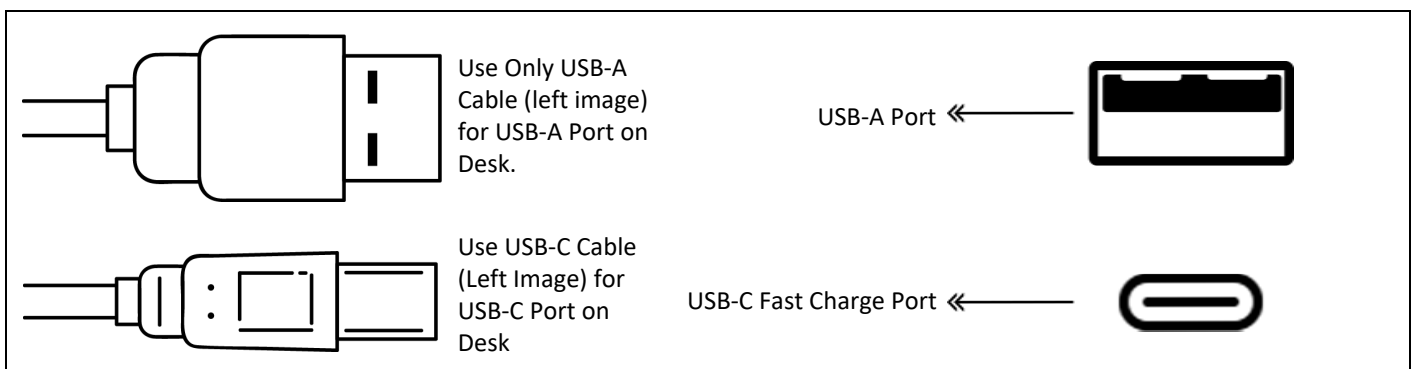

Get help with assembly and report damaged or missing parts.

Email: Support@SevilleClassics.com

Telephone: 1 (800) 323-5565

Hours (M-F): 8:30 AM - 4:30 PM (PST)

airLIFT Electric Tempered Glass Height Adjustable Desk (Model No. OFF65991, OFF65992)



*NOTE: We recommend using TWO people to assemble the desk.



Error Code List		
Code	Meaning	Action
SC0	Self-Check Fail - Standby Mode Error	Re-plug in the power cable. If the alert does not clear, please contact customer service.
SC1	Self-Check Fail - Main Power Error	Re-plug in the power cable. If the alert does not clear, please contact customer service.
SC2	Self-Check Fail - Save Memory Error	Re-plug in the power cable. If the alert does not clear, please contact customer service.
SC3	Self-Check Fail - Sensor Error	Re-plug in the power cable. If the alert does not clear, please contact customer service.
R-2	Table Tilt Alert	The desk will run in the opposite direction for about 2" automatically, then the alert will clear.
R-3	Sync Failure	Reset the desk, refer to page 10 for instructions on how to reset the desk.
HOT	Overheat Protection	Let the motors cool down for 18 minutes.
R-5	Control system malfunction	Check the connection of the power cable and LED control panel, refer to image on page 8.
R-6	Voltage irregularity	Contact customer service.
RST	Not reset completely	Reset the desk, refer to page 10 for instructions on how to reset the desk.
EX0	Driver Short-Circuit	Re-plug in the power supply. If the alert does not clear, contact customer service.
EX1	Over-Load Protection	Remove some weight from the desk, then the alert will clear after 20 seconds.
EX2	Motor Phase Failure	Check the connection of motor cable, refer to image on page 8.
EX3	Moving Direction Error	Please contact customer service.
EX4	Anti-collision	The desk will run in the opposite direction for about 2" automatically, then the alert will clear.
EX5	Motor Stalling Alarm	Contact customer service.
EX6	Motor wire not connected	Check the connection between motor cable and the LED control panel, refer to image on page 8.
EX7	Mechanical Malfunction	Contact customer service.



Get help with assembly and report damaged or missing parts.

Email: Support@SevilleClassics.com

Telephone: 1 (800) 323-5565

Hours (M-F): 8:30 AM - 4:30 PM (PST)

CONTACT INFORMATION

If you are missing any parts, have any questions, or need additional assistance in assembly, please contact our bilingual (English and Spanish) customer service department at:



Seville Classics, Inc.

19401 Harborgate Way Torrance, CA 90501 USA

Telephone: (800) 323-5565 within USA

Fax: (310) 533-3899

Hours: 9:00am - 4:30pm (Pacific Standard Time)

E-mail: support@sevilleclassics.com

Website & Online Store: www.sevilleclassics.com

NOTE: This equipment has been tested and found to comply with the limits for Class B digital device, pursuant to part 15 of the FCC Rules. These limits are designed to provide reasonable protection against harmful interference in a residential installation. This equipment generates, uses and can radiate radio frequency energy and, if not installed and used in accordance with the instructions, may cause harmful interference to radio or television reception, which can be determined by turning the equipment off and on, the user is encouraged to try to correct the interference by one or more of the following measures:

- Reorient or relocate the receiving antenna.
- Increase the separation between the equipment and the receiver.
- Connect the equipment into an outlet on a circuit different from that to which the receiver is connected.
- Consult the dealer or an experienced Radio/TV technician for help