

Model No. 18290

PNEUMATIC WORK STOOL – ASSEMBLY INSTRUCTIONS

A - 1 piece

Seat

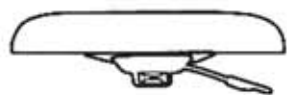

B - 1 piece

Pneumatic Cylinder



C - 1 piece

Cover



D - 1 piece

Base

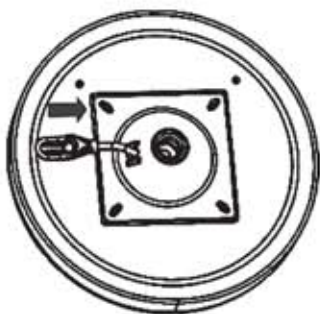
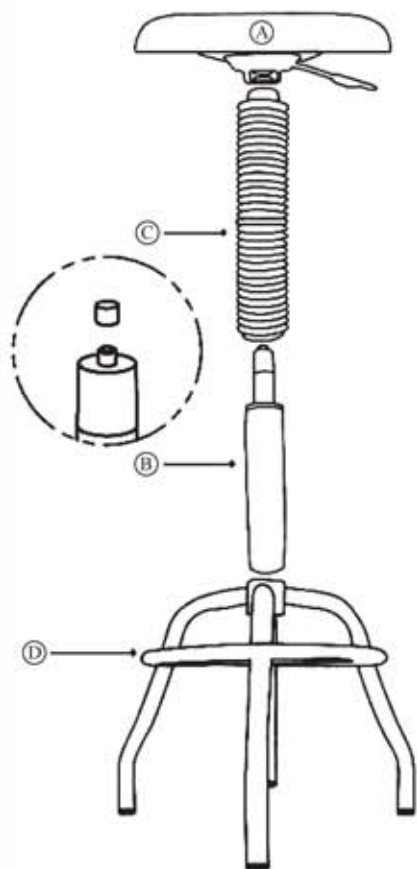

Step 1:

Insert the large end of **Pneumatic Cylinder (B)** into the collar of **Base (D)**.

Step 2:

Slide **Cover (C)** over **Pneumatic Cylinder (B)**.

Step 3:

First, remove the cylinder protection cap, then place the **Seat (A)** onto the small end of the **Pneumatic Cylinder (B)**.

WARNING: Maximum weight capacity 300 lbs (136 kg)
Periodically, tighten screws to prevent seat from coming loose.

Customer Service

support@sevilleclassics.com

Monday through Friday 8:30 am - 4:30 pm (Pacific Time)



Seville Classics, Inc.

Torrance, CA 90501 USA

www.sevilleclassics.com

Please read and save these instructions

©2016 Seville Classics, Inc.