

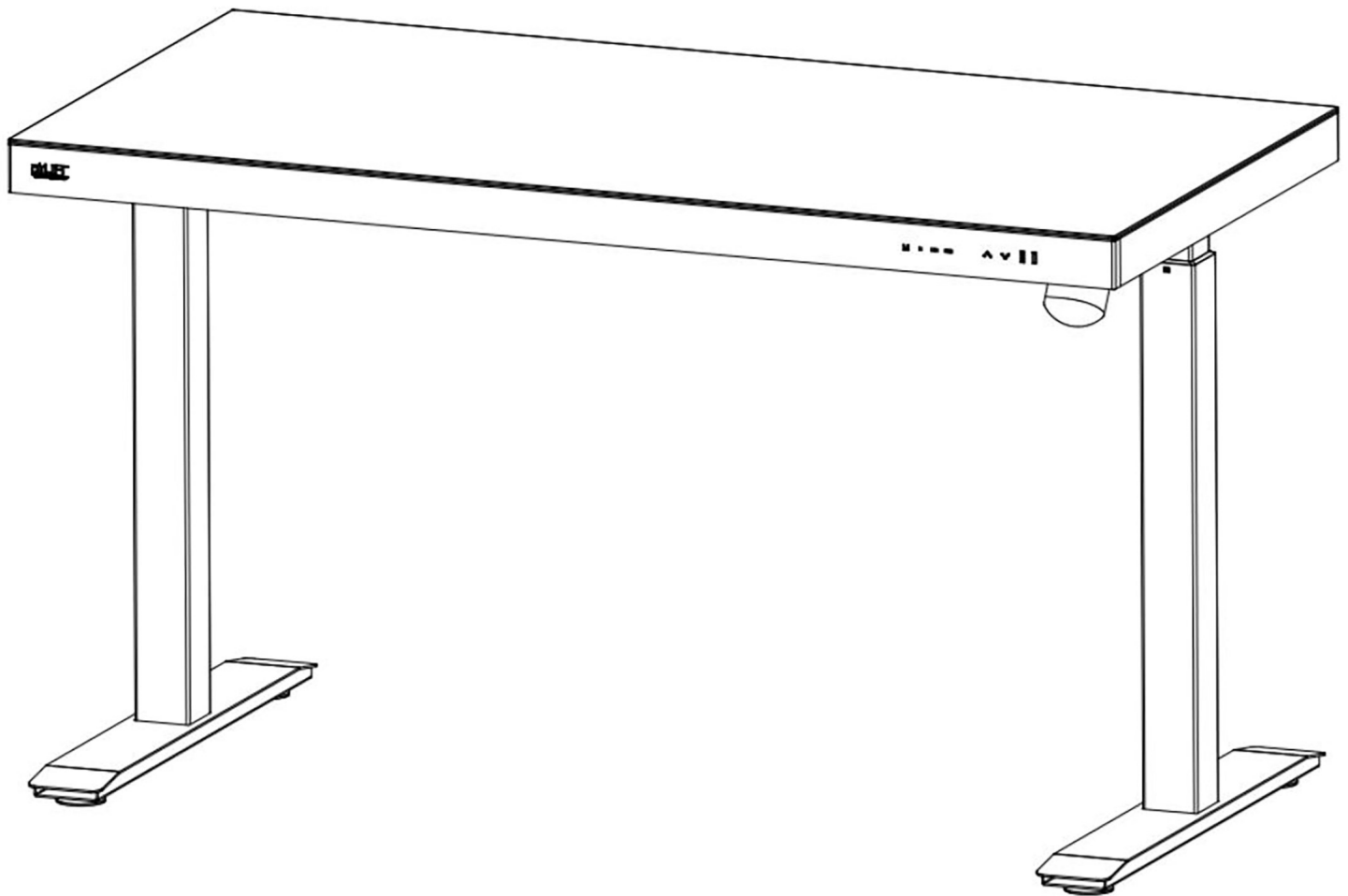

## airLIFT® 48" Tempered Glass Height Adjustable Standing Desk



Models: OFF65927

Thank you for choosing Seville Classics! We hope that you enjoy your new sit-to-stand desk. Please read through this user guide for parts list, instructions, frequently asked questions and contact information.

# Welcome!

We at Seville Classics® are thrilled that you've chosen to go airLIFT®! Our desks are some of the easiest to use, most versatile and sophisticated electronic desks on the market. With this, you can stay active throughout the day without sacrificing productivity.

Choosing a height-adjustable desk is not just a convenient upgrade—it's a healthy one! Too much sedentary behavior can present a real health risk, even for people who are already healthy. Simply getting up throughout the day and moving is a great way to fight the consequences of too much sitting. airLIFT® is here to help.

Please read through this manual for more information regarding your airLIFT® Electric Height Adjustable Standing Desk.

Thank you for choosing Seville Classics®! We hope you will enjoy this desk for many years to come.

# Table of Contents

SAFETY INSTRUCTIONS.....	3
QUICK SETUP.....	4
PARTS LIST.....	5
TOOLS & HARDWARE LIST.....	5
ASSEMBLY INSTRUCTIONS.....	6
Attach Brackets to Legs.....	6
Attach Legs to Top.....	7
Connect Motor.....	8
Installing Feet.....	9
Turn Desk Over.....	10
INITIALIZATION & USE INSTRUCTIONS.....	11
TROUBLESHOOTING.....	12
WARRANTY INFORMATION.....	13
FCC INFORMATION.....	14
CUSTOMER SERVICE INFORMATION.....	15

# Safety Instructions



FAILURE TO COMPLY WITH OR OBSERVE ALL ASSEMBLY, SAFETY AND OPERATING INSTRUCTIONS AND WARNINGS REGARDING THE USE OF THIS PRODUCT MAY RESULT IN SERIOUS BODILY INJURY



- Read and understand this manual before attempting to install or operate.
- Assure that everyone who uses this product is informed of the contents of this manual. This is the responsibility of the Purchaser.
- Not intended for use by young children or for those persons who require supervision.
- Do not open any of the components – legs, control box, or controller. There is a risk of electric shock.
- Assemble desk on a flat and level surface.

## Use & Liability

Safe use of this product is possible only when the operating instructions are read completely and the instructions contained are strictly observed. Persons who do not have the necessary experience or knowledge of this product must not use the product. Persons with reduced physical or mental abilities should not use this product, unless they are under supervision or they have been thoroughly instructed in the use of the apparatus by a person who is responsible for the safety of these persons. Children should be closely supervised to ensure that they do not play with this product.

## Before You Begin

Layout all components and hardware. Visually examine and make sure components are free of damage. If there is visual damage to any component, it must not be installed.

Two people are needed to turn or move the desk and some of its components. When moving or turning the assembled desk, grab the legs, not the desk top.

Make sure to assemble on a soft and non-abrasive surface to avoid scratches.

Check all connections and cables. Make sure control box is connected to a power outlet.

If the control box makes unusual noises or emits an odor, switch power off immediately.

** The desk MUST be INITIALIZED before first use.  Read the INITIALIZATION chapter prior to operation. **

# Quick Setup!

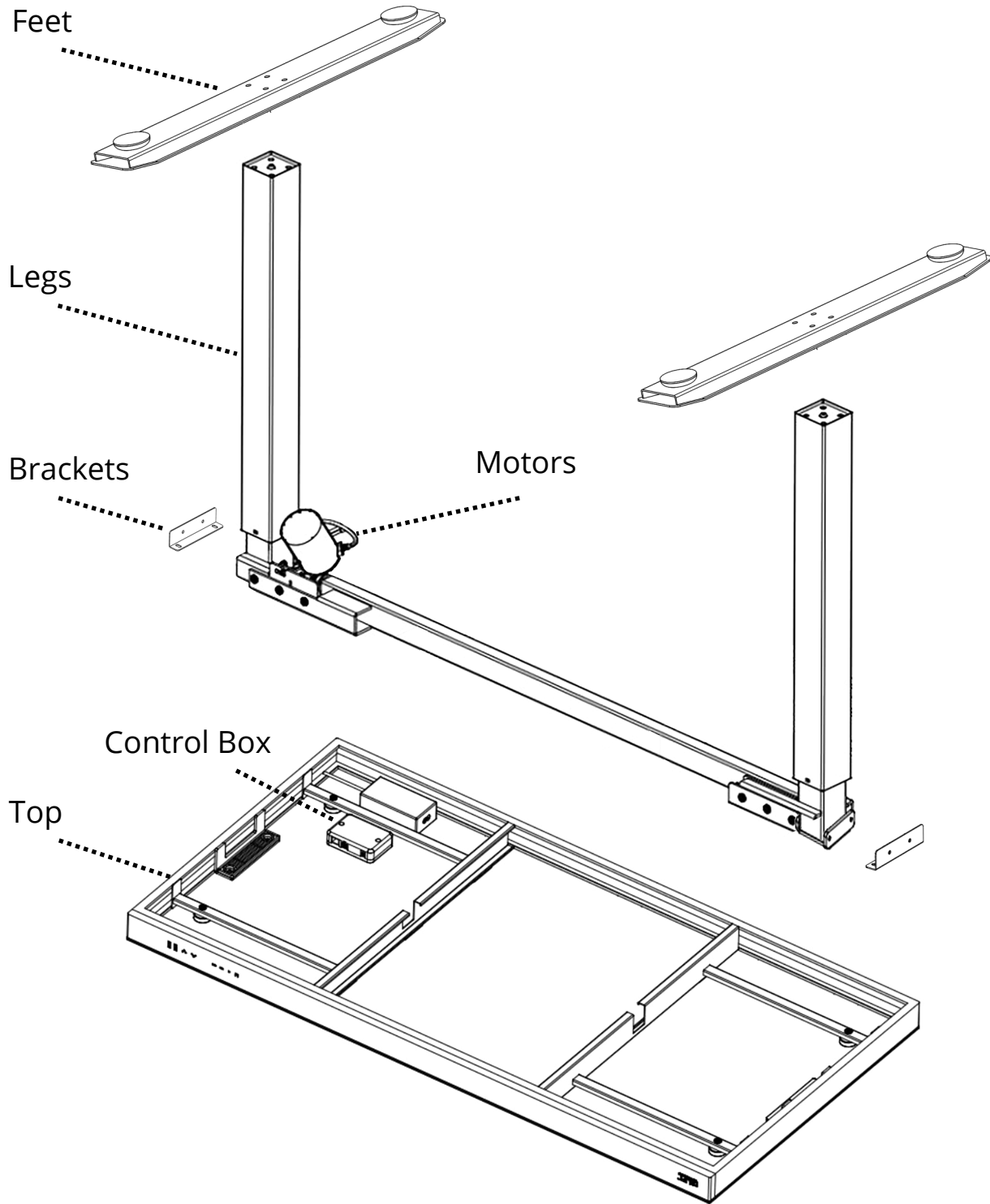

Only takes 15 minutes to complete. All required tools are included.  
Keep the top in the box during assembly to protect it from scratches.

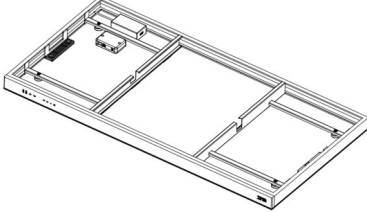
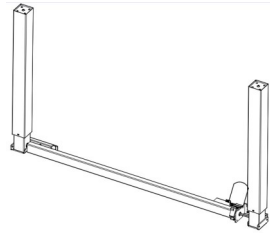
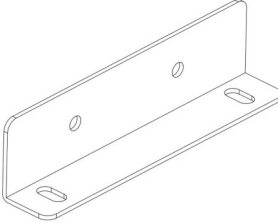
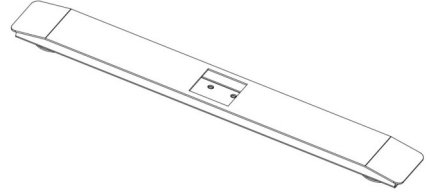

# Parts List

A. Top (1)	
B. Legs (1)	
C. Brackets (2)	
D. Feet (2)	

# Tools & Hardware List

E. M6x12 Screws (8)	
F. M8x30 Screws (8)	
G. 4 mm Hex Key	
H. 5 mm Hex Key	

**Please make sure you have all the parts on this list.  
Leave the Top in the box during assembly**

If you're missing parts, contact us for replacements at (800) 323-5565 or send an email to [Support@SevilleClassics.com](mailto:Support@SevilleClassics.com)

**STEP 1.**

Attach **BRACKETS (C)** to sides of **LEGS (B)** with **M6x12 SCREWS (E)** using **4 mm HEX KEY (G)**.

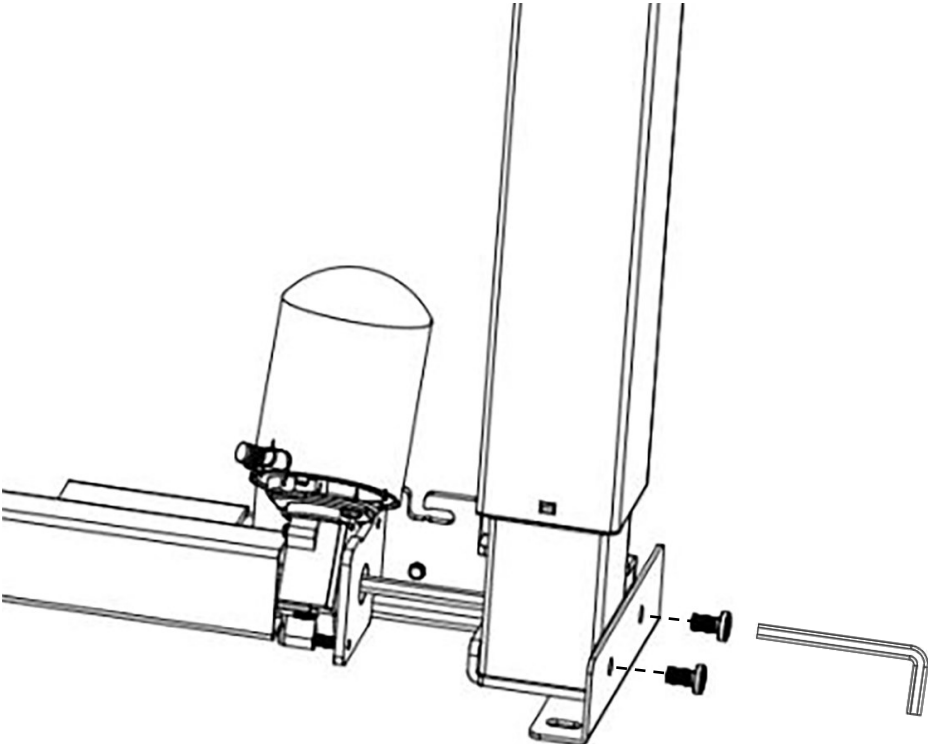
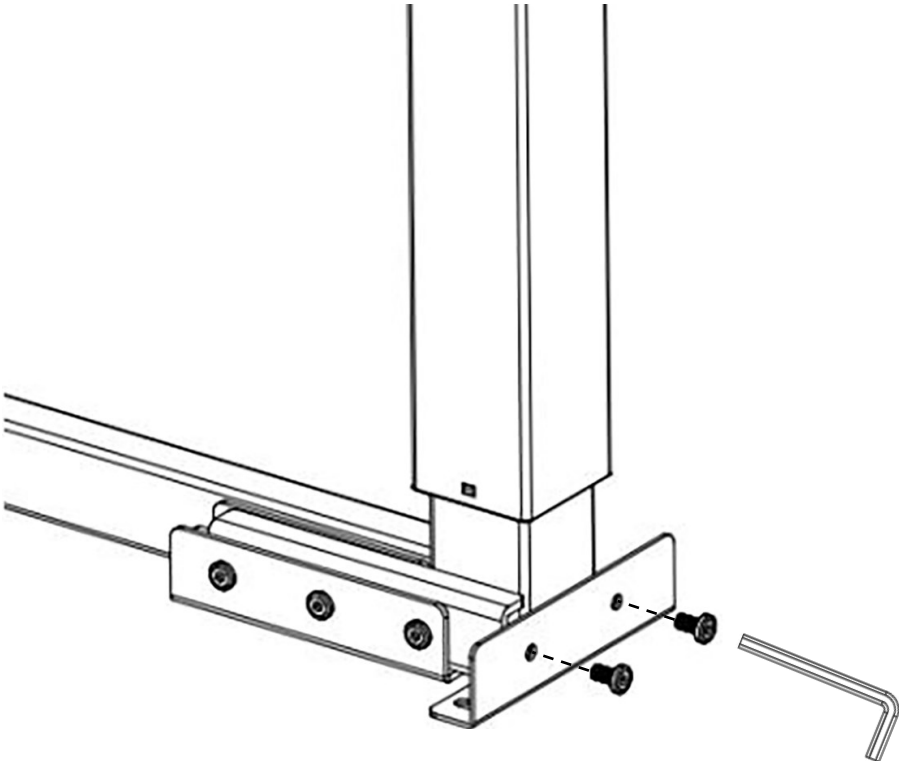

## STEP 2.

Align holes on **BRACKETS (C)** and attach with **M6x12 SCREWS (E)** using **4 mm HEX KEY (G)**. Make sure the motor is on the same side as the control box.

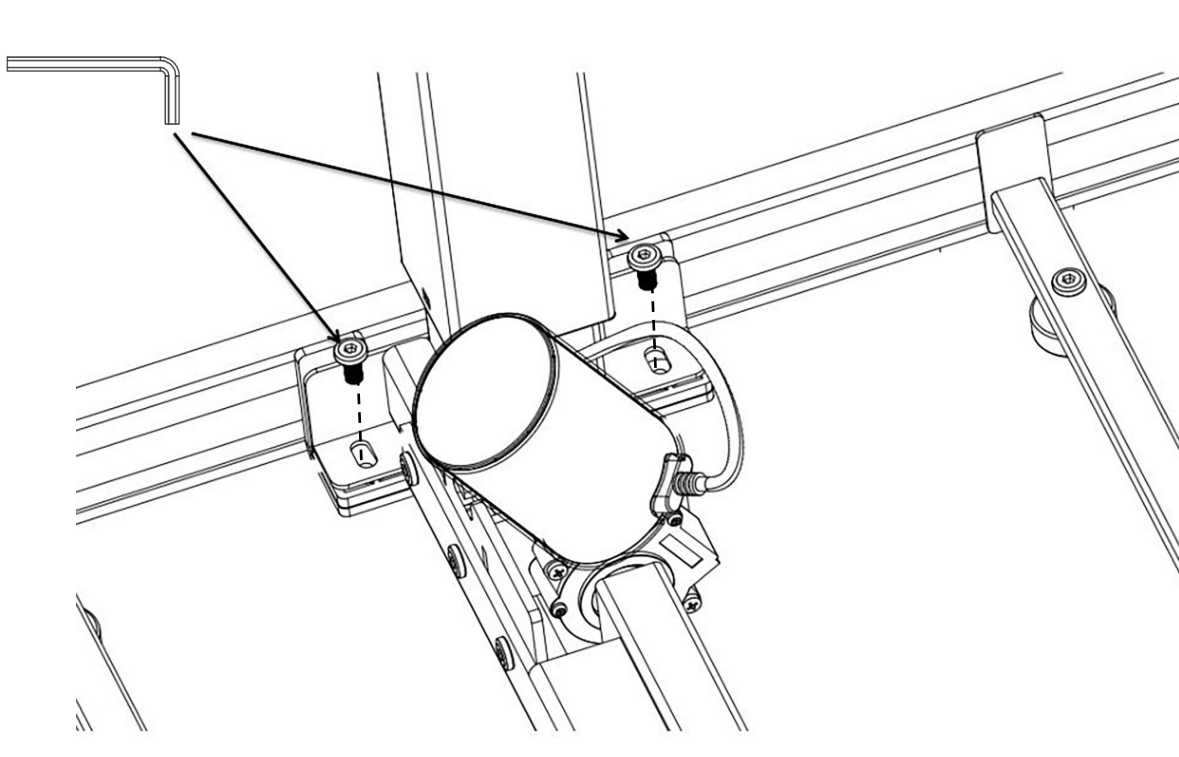
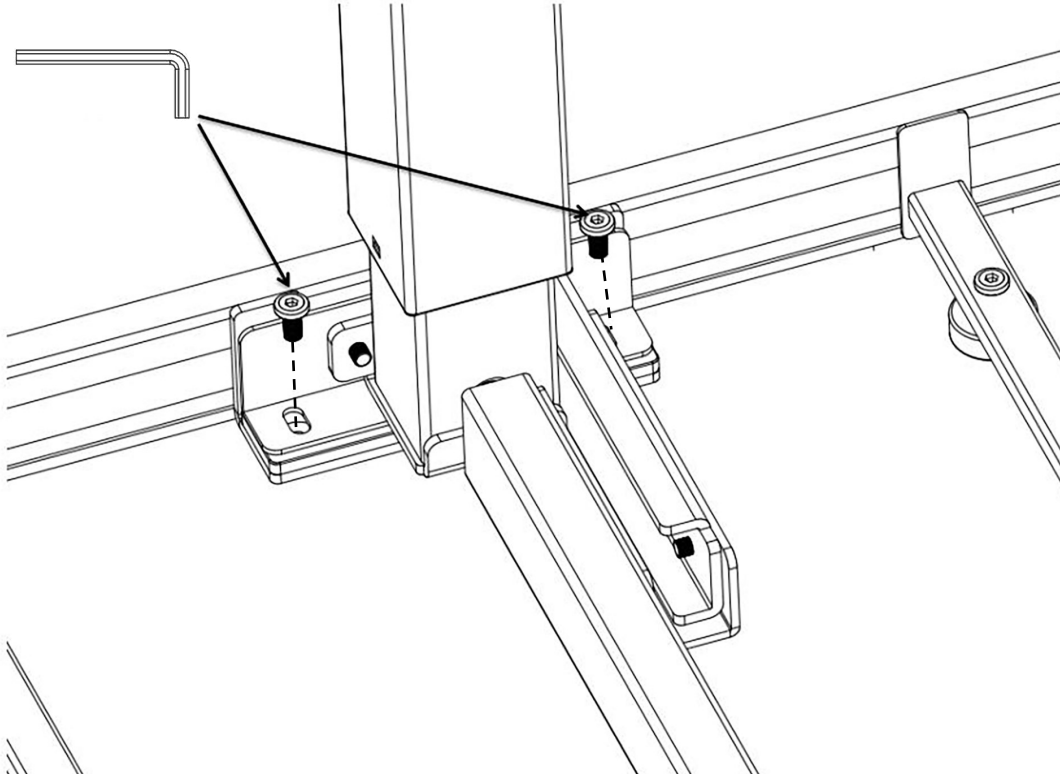

### STEP 3.

Connect the plugs from the motor to the control box.

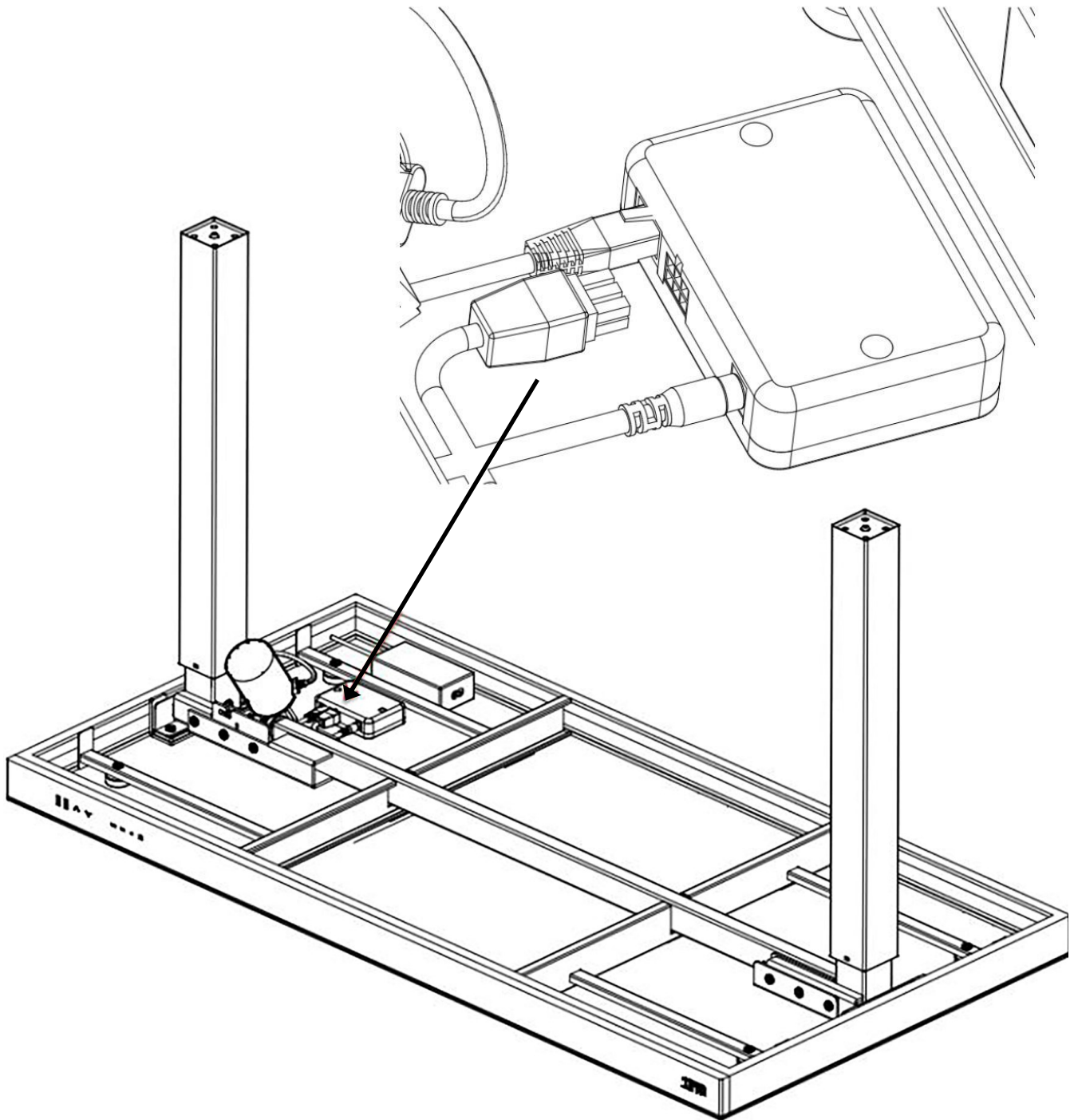

#### STEP 4.

Attach **FEET (D)** to the bottom of table legs with four **M8x30 BOLTS (F)** using **5 mm HEX KEY (H)**.

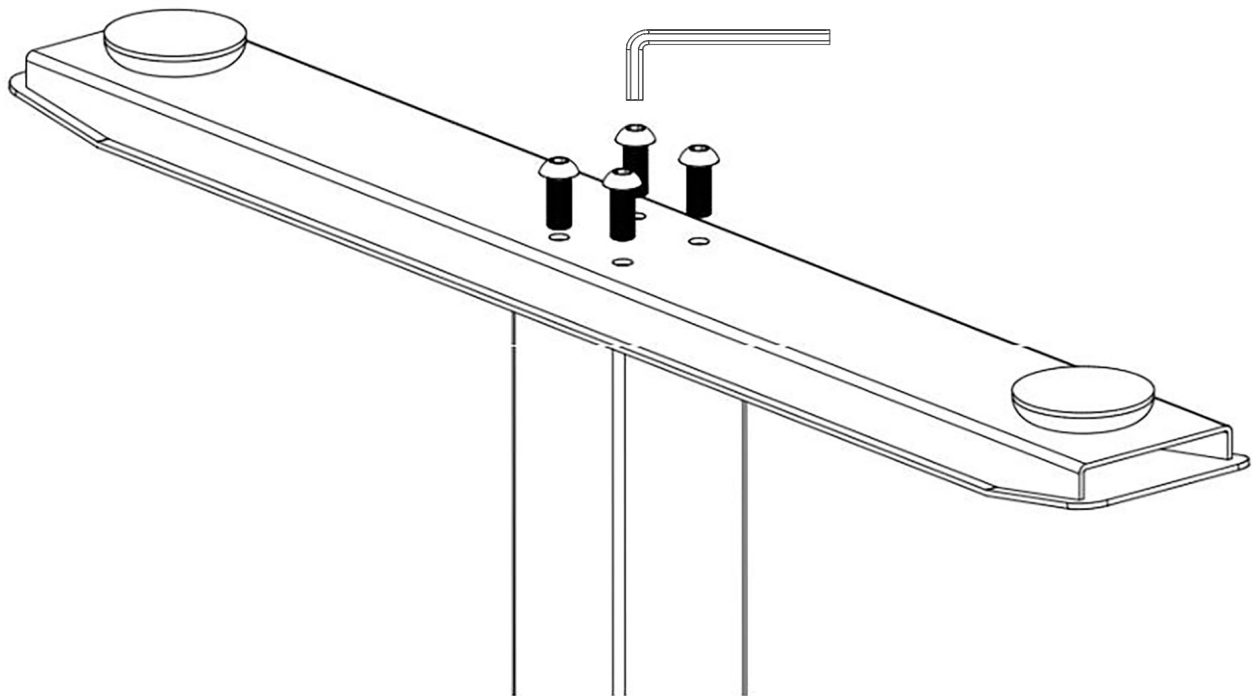

Take this time to make sure all screws, bolts, and cables have been secured tightly.





WARNING: TWO PEOPLE ARE NECESSARY TO TURN TABLE.  
DESK IS HEAVY. LIFT WITH EXTREME CAUTION.



**STEP 5.** Turn the desk onto its feet.

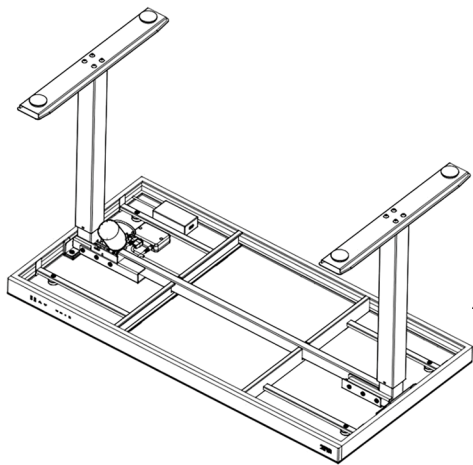

Lift with 2 people

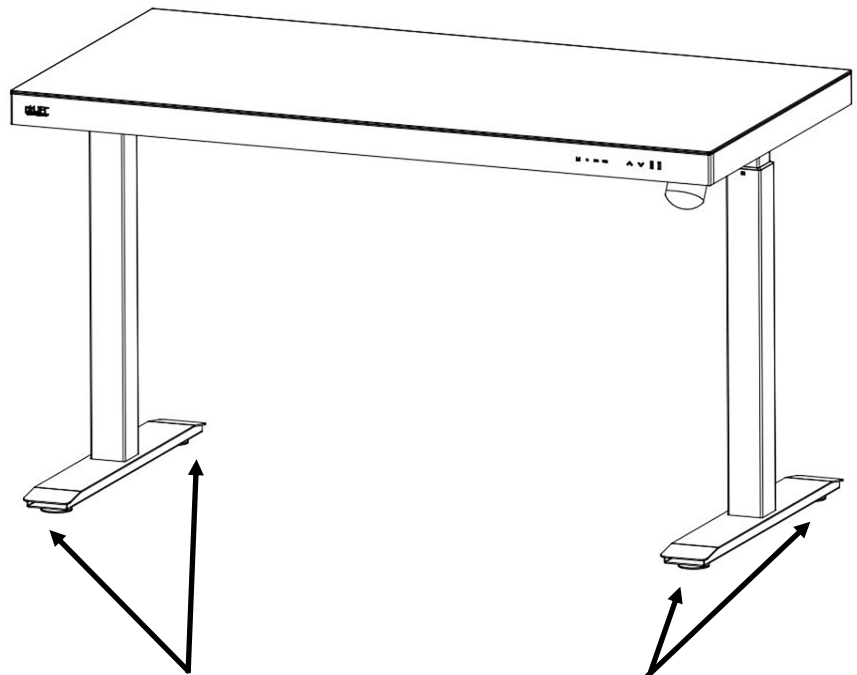
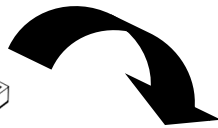

**TIP:** Screw the leveling feet in and out as necessary to ensure the desk stands level.



**DO NOT** put weight on desk yet.



# Use Instructions

## DESK MUST BE INITIALIZED BEFORE FIRST USE

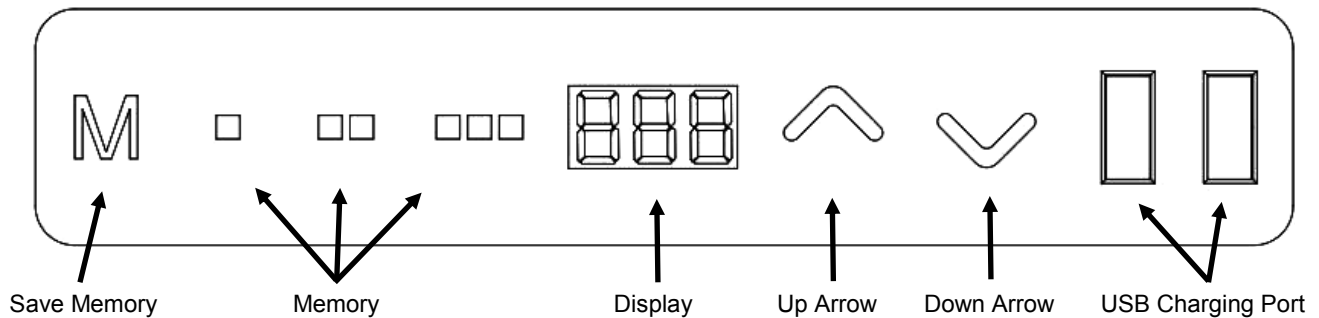

### Initialize & Reset

Press and hold the **Down Arrow** until the desk reaches its lowest point.

Initialization is complete when the desk emits a chime sound and rebounds. When **28 (+/-1)** appears on the display, the desk is ready.

When RST appears on the display, follow the above instructions to reset.

### Adjust Height

Press and hold the **Up Arrow** to lift.  
Press and hold the **Down Arrow** to lower.

### Save Height

Press **M button** until "S-" appears on the display.  
Then press a memory button to save height.

### Recall Height

Press the desired memory button. The desk will then adjust to the stored height.

### Limit Height

Press the **Up Arrow + Down Arrow** for 5 seconds until chime is heard.  
Cancel by pressing **Up Arrow + Down Arrow** for 5 seconds until buzzer is heard.

### Lock Controller

Press the **M button + Up Arrow** for 5 seconds to lock the controller. LOC will display.  
Press the **M button + Down Arrow** for 5 seconds to unlock the controller.

## Troubleshooting

Problem	Action
Desk does not go up or down and the controller <b>does not illuminate</b> when any button is pressed.	Check all connections. Make sure power cord is plugged into the control box and a power outlet. Press any button on the controller and make sure it illuminates. Reset the desk.
Desk does not go up or down and the controller <b>illuminates</b> when any button is pressed.	Unplug the power cord and re-plug after 10 seconds. Reset the desk. If the problem persists, switch motor cables from one port to another at control box and reset again.
Columns do not go up evenly.	Unplug the power cord and re-plug after 10 seconds. Reset the desk. If the problem persists, switch motor cables from one port to another at control box and reset again.
Desk wobbles excessively.	It is normal that desk moves slightly at standing height when in use. Retighten all screws and bolts, and adjust leveling feet to make sure table stands level.
Desk legs are noisy.	It is normal that desk makes noise when the stages move past each other. Apply silicon-based lubricant if it is unusually noisy.

## Error Codes

Error Code	Problem	Action
E01, E06, E07	Power fault	Unplug and re-plug the power cord. Reinitialize the desk.
E02, E08	Desktop sloping	Make sure the desk is attached to the legs correctly. Reinitialize the desk.
E04	Handset fault	Unplug and re-plug the controller cables. Reinitialize the desk.
E05	Anti-collision	Make sure nothing obstructing the desk from adjusting.
E11, E13,	Connection cable failure	Unplug and re-plug the motor and power cables. Reinitialize the desk.
E12	Controller fault	Please contact customer service.
E14 to E16	Motor fault	Unplug and re-plug the motor and power cables. Reinitialize the desk.
E17	Motor running direction fault	Unplug and re-plug the motor and power cables. Reinitialize the desk.
E18	Overloading	Remove some weight from the desk top until error clears.
HOT	HOT is displayed on the panel.	The desk motors are overheated. Stop using the desk for 20 minutes and let them cool down.

Please contact customer service for additional support.

Phone: (800) 323-5565 | Email: [Support@SevilleClassics.com](mailto:Support@SevilleClassics.com)

# Warranty Information

## 7-Year Non-Electronic Component Warranty

Seville Classics, Inc. warrants to the original retail purchaser that if this product proves to be defective in material or workmanship, we will replace the affected **non-electronic part(s)** for a period of **seven years** on Seville Classics airLIFT® Electric Height Adjustable Standing Desks from the date of original purchase.

## 2-Year Electronic Component Warranty

Seville Classics, Inc. warrants to the original retail purchaser that if this product proves to be defective in material or workmanship we will replace the affected **electronic part(s)** for a period of **two years** on Seville Classics airLIFT® Electric Height-Adjustable Standing Desks from the date of original purchase.

Except for the express warranty set forth above and except to the extent prohibited by applicable law, Seville Classics grants no other express or implied warranties with respect to the product, its fitness for any purpose, its quality, or its merchantability. The liability of Seville Classics under the warranty shall be limited to the amount paid by the customer for the product. Seville Classics shall not be liable for any loss of use of the product, or other incidental or consequential costs, expenses or damages incurred by the customer or other user.

This warranty covers only the airLIFT® Height Adjustable Standing Desk sold in the United States of America and Canada. Some states do not allow the exclusion or limitations of implied warranties or consequential damages, so the above limitations or exclusions may not apply to you. This warranty gives you specific legal rights, and you may also have other rights that vary from state to state.

During the applicable warranty period, Seville Classics, at its option, will either refund the original purchase price or replace the affected part(s) with comparable part(s) when the affected part(s) are returned, postage prepaid, to the address below:

Seville Classics Inc.  
19401 South Harborage Way  
Torrance, CA 90501 – 1322 U.S.A.

To obtain service under this warranty, you must:

1. Register your product at [www.SevilleClassics.com/warranty](http://www.SevilleClassics.com/warranty)
2. Contact our customer service at (800) 323-5565 or email [support@sevilleclassics.com](mailto:support@sevilleclassics.com);
3. Return the affected part(s) postage prepaid to Seville Classics pursuant to our customer service representative; and
4. Include in the package:
  - A. A copy of the original bill of sale, your charge or credit receipt, or other satisfactory proof of the date of the original purchase date of the product, and the price paid; and
  - B. A short detailed description of the problem, the name and phone number of the contact person.

NOTE: This equipment has been tested and found to comply with the limits for Class B digital device, pursuant to part 15 of the FCC Rules. These limits are designed to provide reasonable protection against harmful interference in a residential installation. This equipment generates, uses and can radiate radio frequency energy and, if not installed and used in accordance with the instructions, may cause harmful interference to radio or television reception, which can be determined by turning the equipment off and on, the user is encouraged to try to correct the interference by one or more of the following measures:

- Reorient or relocate the receiving antenna.
- Increase the separation between the equipment and the receiver.
- Connect the equipment into an outlet on a circuit different from that to which the receiver is connected.
- Consult the dealer or an experienced Radio/TV technician for help

# Customer Service Information

**Telephone:** (800) 323-5565

**Fax:** (310) 533-3899

**Hours:** 8:30 AM – 4:30 PM (PST)

**Email:** [Support@SevilleClassics.com](mailto:Support@SevilleClassics.com)

**Homepage:** [www.SevilleClassics.com](http://www.SevilleClassics.com)