

IMPORTANT!! PLEASE READ ENTIRE INSTRUCTION SHEET BEFORE ASSEMBLY!!
TO EXPEDITE ANY FUTURE WARRANTY CLAIMS, PLEASE KEEP INSTRUCTION SHEET, WARRANTY CARD AND RECEIPT

Step 1: Identify parts packed in the carton against the parts list. Remove all protective materials and set parts on a flat, non-abrasive surface. Place the natural stone table top upside down on a flat, non-abrasive surface. If you are missing any parts or are unsure how to proceed with assembly, please call our Customer Service Center immediately at 1-800-416-3511. **Do not attempt to assemble table if any parts are missing or damaged.**

Step 2: Attach a table leg to the leg connector bracket by using 1/4"x35 mm bolt and washer as shown in Fig.1. Guide the bolt through the hole in the leg connector bracket into the pre-drilled hole in the table leg. **Hand tighten only 2-3 revolutions.** Repeat on the other three legs.

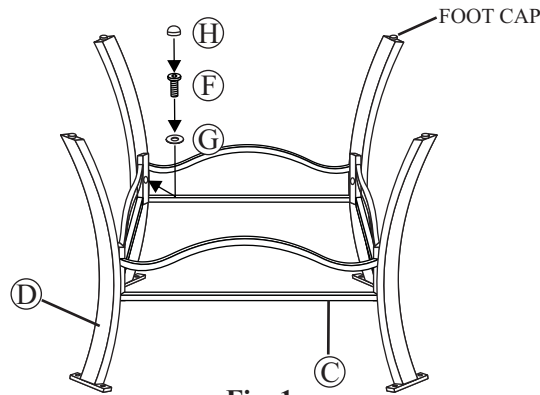

Fig. 1

Step 3: Attach the completed base to the table rim by using the 1/4"x30 mm bolts and washers, as shown in Fig.2. Guide the bolt through the hole in the table leg into the pre-drilled hole in the table rim. **Hand tighten only 2-3 revolutions.** Repeat for the other three legs.

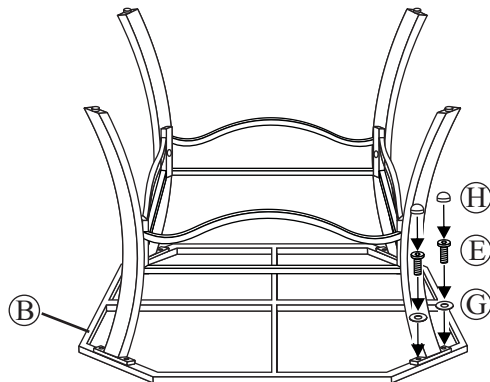

Fig. 2

Step 4: After making any necessary adjustments to the alignment of the table legs and the leg connector bracket, use the hex bolt driver and hex wrench to tighten all nuts and bolts. **Note:** each bolt and nut must be tightened a few revolutions at a time. In order to apply equal pressure to all bolt joints, we recommend working in a cross corner "X" pattern. Repeat until bolts and nuts are tight. **Do not over tighten.**

Step 5: With the help of another person, turn the table assembly in the upright position. With the help of another person, carefully place the natural stone table top onto the table base. After making any necessary adjustments to the alignment of the natural stone table top and the table rim, use the 1/4"x35 mm bolts and Ø18x1.5 mm washers as shown in Fig.3. Guide the bolt through the table rim, into the pre-drilled hole on the underside of the natural stone table top. **Do not tighten completely.** Repeat on the other three holes of the table rim. (Note: holes do not go through to the top of the table. Holes shown for illustration purposes only.)

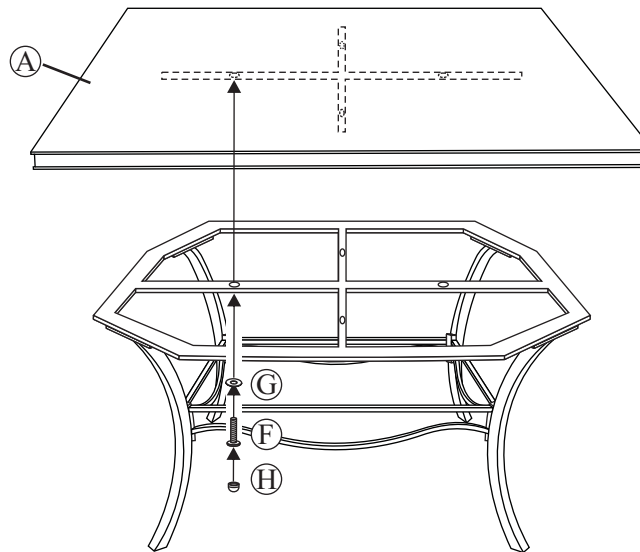

Fig. 3

Step 6: At this time, use the hex bolt driver to tighten all bolts in the table top. **Note:** each bolt must be tightened a few revolutions at a time. In order to apply equal pressure to all bolts joints, we recommend working in a cross corner "X" pattern. Repeat until all bolts are tight. **Do not over tighten.** Cover all bolts with covers. Do not roll the table on its edges or drag the table. To move the table, use the assistance of another person to lift and carry the table.

Step 7: Adjust the footcaps as necessary by turning them to a level that prevents the table from rocking. Your natural stone table is now ready for use. If you use an umbrella, please add an umbrella hole protective ring to the umbrella hole on the natural stone top table. If you have any questions, please call our Customer Service Center at 1-800-416-3511.

IMPORTANT NOTE: Damage to welds or frames resulting from over tightened bolts or improper assembly is not covered under our warranty. Please read all instructions carefully before assembly. If you have any questions regarding your assembly, call our Customer Service Center at 1-800-416-3511.

** NOTE: PARTS SHOWN ON PARTS LIST ARE NOT TO SCALE*

	PARTS LIST	DESCRIPTION	ORDER PART #	QTY
A		NATURAL STONE TABLE TOP	ST0717	1
B		TABLE RIM	ST0718	1
C		LEG CONNECTOR BRACKET	ST0719	1
D		TABLE LEG	ST0720	4
E		1/4" X 30 MM BOLT	HW0038	8
F		1/4" X 35 MM BOLT	HW0142	12
G		Ø6.5 X 1.0 MM WASHER	HW0004	16
H		BOLT COVER	HW0105	20
I		HEX BOLT DRIVER	HW0006	1
		FOOT CAP FACTORY ASSEMBLY	FC0030	

BLS05713

CARE AND MAINTENANCE

FRAMES

Cleaning - Use mild soap and warm water. Do not use abrasive materials, cleansers or bleach products. Rinse with clean water and dry thoroughly.

Maintenance Periodically clean and dry thoroughly. Be sure to drain any water accumulated inside the frames. To thoroughly drain frames, remove foot caps and tilt the frames, if necessary, to remove all water. This is critical. Water allowed to accumulate inside the frames and then exposed to sub-freezing temperatures can cause damage to the frame tubing. Such damage is not covered under warranty. Always clean, drain and dry thoroughly before storing for the winter. For best results, always store or cover your furniture when not in use. We recommend commercially available outdoor furniture covers. Any rust spots should be lightly sanded, treated with a commercially available rust inhibitor and followed by an application of touch-up paint. Any small nicks or scratches can be covered with a light application of touch-up paint.

** When cleaning or moving large or heavy items, always have two people work together. Never drag furniture.

NATURAL STONE

To ensure the lasting beauty of your stone tabletop, please refer to the special stone care label that is attached to the underside of your stone tabletop. Detailed care and maintenance instructions are also available by visiting our website at www.agio-usa.com/stonecare or by calling our Customer Service Center at 800-416-3511.

SPECIAL WARNINGS!!!

TABLETOP WARNING!

PLEASE TAKE PRECAUTIONS AND DO NOT ALLOW ANYONE TO CLIMB, STAND, CRAWL OR WALK ON THE TOP OF THE TABLE. ALWAYS TAKE PRECAUTIONS TO PROTECT YOUR TABLETOP DURING STORMS AND HIGH WINDS.

LIMITED 1 YEAR WARRANTY

- **Frames.** Frame construction is warranted against defects in materials or workmanship for one year from purchase date. Damage to frames or welds resulting from improper assembly or exposure to water and/or sub-freezing temperatures is not covered. General frame rusting is not covered.
- **Finishes.** Paint finishes are warranted against peeling, cracking or blistering for one year from purchase date provided the unit has not been scratched or abraded. Chips and scratches resulting from normal wear and tear are not covered.
- **Fabrics.** Fabric and cushions (if applicable) are warranted against separation at the seams for one year from purchase date. Fading and/or discoloration resulting from exposure to the elements, oils, spills, fluids, chemicals, or any other cause is not covered.
- **Straps and/or wicker.** Straps and/or wicker weave (if applicable) are warranted against separation and tearing for one year from purchase date. Fading and/or discoloration resulting from exposure to the elements, oils, spills, fluids, chemicals, or any other cause is not covered.
- **Umbrellas.** Umbrellas (if applicable) are warranted against manufacturer's defects only for one year from purchase date. Umbrella bases (if applicable) are not covered under any circumstances.
- **Table tops.** Natural stone tabletops only are warranted against defects in materials and workmanship only for one year from purchase date. All table tops (including without limitation glass and faux stone) are not covered under any circumstances.

Warranty limitations: This warranty is to the original purchaser only when purchased from one of our authorized dealers and is not transferable. We will pay shipping and handling charges for replacement items within the North American continent during the first year of ownership on all valid warranty claims. After the first year, shipping and handling charges are the responsibility of the claimant/owner. We shall not be responsible for charges associated with shipments outside of the North American continent at any time.

Warranty exclusions: The following are excluded from coverage under this limited warranty: any item used for commercial, contract or any other non-residential purpose; clearance items, display models or items purchased "as is"; freight damage; items subject to misuse, abuse, or lack of proper care or maintenance; damage caused by acts of nature, acts of force majeure, vandalism, fire or improper assembly; hardware against corrosion or rusting; purchased or replacement parts; and all plastic parts. Also excluded are loss of use or time; inconveniences; money, travel, packaging or incidental, special or consequential damages of any kind. Replacement of defective items as provided herein shall constitute the sole and exclusive remedy of the purchaser for items which are not as warranted. In no event shall our responsibility exceed the purchase price of the item found to be other than as warranted. This warranty is the exclusive statement of your rights with respect to defects in the items you have purchased and supersedes any other expressed warranty or statement, written or oral, made in connection with the purchase and sale of those items. When used herein, the term "item" refers to the specific item found to be defective, and not to the entire set of which the item is a part.

Some states do not allow exclusion or limitation of incidental or consequential damages, so that limitation above may not apply to you. This warranty gives you specific legal rights, and you may also have other rights which vary from state to state.

WOVEN DESIGN CO., LTD

PATIO FURNITURE & ACCESSORIES ASSEMBLY INSTRUCTIONS

IMPORTANT!!!

STOP! PLEASE READ THESE INSTRUCTIONS CAREFULLY BEFORE ASSEMBLY. MAKE SURE YOU HAVE ALL THE PARTS AND HARDWARE AS IDENTIFIED ON THE PARTS LIST.

MISSING PARTS? DAMAGED PARTS? DON'T GO BACK TO THE RETAILER. WE CAN HELP YOU FASTER!

CALL OUR CUSTOMER SERVICE CENTER AT 1-877-465-2084 BETWEEN 9:00AM AND 5:00PM (EASTERN TIME) MONDAY THROUGH FRIDAY (CLOSED HOLIDAYS). OR EMAIL US AT customerservice@va-cs.com.

OR, VISIT OUR WEBSITE AT: www.shianco.com

TO EXPEDITE ANY FUTURE WARRANTY CLAIMS, RETAIN THE INSTRUCTION SHEET, WARRANTY CARD AND RECEIPT FOR FUTURE USE. YOU ARE ENCOURAGED TO REGISTER YOUR PURCHASE ON OUR WEBSITE AT www.shianco.com