



COMBINATION HOT DOG STEAMER & BUNWARMER

MODEL
35SSC STEAMRO

**Installation and
Operation
Instructions**

2M-Z6693 Rev.B 6/11/12



35SSC



SAFETY SYMBOL



These symbols are intended to alert the user to the presence of important operating and maintenance instructions in the manual accompanying the appliance.

RETAIN THIS MANUAL FOR FUTURE REFERENCE NOTICE

Using any part other than genuine Star factory supplied parts relieves the manufacturer of all liability.

Star reserves the right to change specifications and product design without notice. Such revisions do not entitle the buyer to corresponding changes, improvements, additions or replacements for previously purchased equipment.

Due to periodic changes in designs, methods, procedures, policies and regulations, the specifications contained in this sheet are subject to change without notice. While Star International Holdings Inc., Company exercises good faith efforts to provide information that is accurate, we are not responsible for errors or omissions in information provided or conclusions reached as a result of using the specifications. By using the information provided, the user assumes all risks in connection with such use.

MAINTENANCE AND REPAIRS

Contact your local authorized service agent for service or required maintenance.

Please record the model number, serial number, voltage and purchase date in the area below and have it ready when you call to ensure a faster service.

Model No. _____

Serial No. _____

Voltage _____

Purchase Date _____

Authorized Service Agent Listing

Reference the listing provided with the unit

or

for an updated listing go to:

Website: www.star-mfg.com
E-mail Service@star-mfg.com

Service Help Desk

Business Hours: 8:00 am to 4:30 p.m. Central Standard Time

Telephone: (314) 678-6303

Fax: (314) 781-2714

E-mail Parts@star-mfg.com
Service@star-mfg.com
Warranty@star-mfg.com

Website: www.star-mfg.com

Mailing Address: Star International Holdings Inc., Company
10 Sunnen Drive
St. Louis, MO 63143
U.S.A



This equipment is designed and sold for commercial use only by personnel trained and experienced in its operation and is not sold for consumer use in and around the home nor for use directly by the general public in food service locations. For equipment to be used by the general public, please contact the factory.

VOLTAGE

The steamer is equipped for use on the voltage specified on the nameplate.



DO NOT CONNECT TO ANY OTHER TYPE OF CURRENT OR THE MACHINE WILL BE SERIOUSLY DAMAGED.

INSTALLATION/OPERATION PROCEDURE

1. Place the unit on a level surface. Pour three to six quarts of water into the hot dog (small) compartment. Do not overfill. (The use of hot water will reduce pre-heat time.) Using distilled water will prolong the life of the heating element.
2. Turn the switch to "on" position and set the thermostat control on "high" until steam is generated.
3. For normal operation set the thermostat control in the center of the range between "high" and "lo."
4. Place hot dogs in small compartment and buns on the wire rack in the large compartment. Arrange the hot dogs and buns so that there is free circulation of steam.
5. To control the amount of steam in the bun compartment, use the adjustable humidity control lever located in the bun compartment under the center cover.
6. Keep the lids closed when not serving.
7. Add water as it becomes necessary to maintain the water level. (Add hot water for best results.)



DO NOT ALLOW THE UNIT TO BOIL DRY. ADD WATER WHEN REQUIRED. DAMAGE TO THE HEATING CIRCUIT CAN RESULT FROM ALLOWING A DRY UNIT TO RUN.

AT THE END OF EACH DAY'S OPERATION

1. Disconnect the lead-in cord from the outlet.
2. Remove any remaining hot dogs and buns.
3. Drain the water through the drain pipe.
4. Remove the perforated tray from the hot dog compartment and the wire rack and steam baffle assembly from the bun compartment. Remove the bun tray, partition and the glass panels. Thoroughly clean the entire unit. Stainless steel, while corrosion resistant, should be cleaned daily to prevent pitting.

POSSIBLE SOURCES OF TROUBLE AND SUGGESTED REMEDIES

Evidence of condensation of the outside of the steamer. Cool air striking the warm surface of the steamer may cause moisture to collect. Protect the unit against cool drafts of air.

Casing of hot dogs burst. Too much steam is being generated. Move the thermostat control to a lower setting.

Buns too soggy or too dry. Too much steam or too little steam will produce this condition. Control the amount of steam by adjusting the thermostat control as required. Also by adjusting the humidity control lever located in the bun compartment under the center cover. If buns are too soggy, try adding buns to the unit after the hot dogs have fully cooked.

Some buns are better adapted for steaming than others; with some experimentation you will find the one best suited to your needs.

Premature failure of the heating element or a buildup of calcium deposits is evidence of not using distilled water.

THOROUGHLY INSPECT YOUR UNIT ON ARRIVAL

This unit has been tested for proper operation before leaving our plant to insure delivery of your unit in perfect condition. However, there are instances in which the unit may be damaged in transit. In the event you discover any type of damage to your product upon receipt, you must immediately contact the transportation company who delivered the item to you and initiate your claim with same. If this procedure is not followed, it may affect the warranty status of the unit.

LIMITED EQUIPMENT WARRANTY

All workmanship and material in Star products have a one (1) year limited warranty on parts & labor in the United States and Canada. Such warranty is limited to the original purchaser only and shall be effective from the date the equipment is placed in service. Star's obligation under this warranty is limited to the repair of defects without charge, by the factory authorized service agency or one of its sub-agencies. Models that are considered portable (*see below*) should be taken to the closest Star service agency, transportation prepaid.

- > Star will not assume any responsibility for loss of revenue.
- > On all shipments outside the United States and Canada, see International Warranty.
- * The warranty period for the Ultra-Max, Hot Plates, Griddles, Charbroilers is (3) years parts & labor.
- * The warranty period for the Star-Max, Charbroilers, Griddles, Hot Plates, Fryers & Finishing Oven is (2) years parts & labor.
- * The warranty period for the JetStar six (6) ounce & Super JetStar eight (8) ounce series popcorn machines is two (2) years.
- * The warranty period for the Chrome-Max Griddles is five (5) years on the griddle surface. See detailed warranty provided with unit.
- * The warranty period for Teflon/Dura-Tec coatings is one year under normal use and reasonable care. This warranty does not apply if damage occurs to Teflon/Dura-Tec coatings from improper cleaning, maintenance, use of metallic utensils, or abrasive cleaners, abrasive pads, product identifiers and point-of-sale attachments, or any other non-food object that comes in continuous contact with the roller coating. This warranty does not apply to the "non-stick" properties of such materials.
- > This warranty does not apply to "Special Products" but to regular catalog items only. Star's warranty on "Special Products" is six (6) months on parts and ninety (90) days on labor.
- > This warranty does not apply to any item that is disassembled or tampered with for any purpose other than repair by a Star Authorized Service Center or the Service Center's sub-agency.
- > This warranty does not apply if damage occurs from improper installation, misuse, wrong voltage, wrong gas or operated contrary to the Installation and Operating instructions.
- > This warranty is not valid on Conveyor Ovens *unless* a "start-up/check-out" has been performed by a Factory Authorized Technician.

PARTS WARRANTY

Parts that are sold to repair out of warranty equipment are warranted for ninety (90) days. The part only is warranted, the labor to replace the part is **NOT** warranted.

SERVICES NOT COVERED BY WARRANTY

1. Travel time and mileage rendered beyond the 50 mile radius limit
2. Mileage and travel time on portable equipment (*see below*)
3. Labor to replace such items that can be replaced easily during a daily cleaning routine, ie; removable kettles on fryers, knobs, grease drawers on griddles, etc.
4. Installation of equipment
5. Damages due to improper installation
6. Damages from abuse or misuse
7. Operated contrary to the Operating and Installation Instructions
8. Cleaning of equipment
9. Seasoning of griddle plates
10. Voltage conversions
11. Gas conversions
12. Pilot light adjustment
13. Miscellaneous adjustments
14. Thermostat calibration and by-pass adjustment
15. Resetting of circuit breakers or safety controls or reset buttons
16. Replacement of bulbs
17. Replacement of fuses
18. Repair of damage created during transit, delivery, & installation OR created by acts of God

PORTABLE EQUIPMENT

Star will not honor service bills that include travel time and mileage charges for servicing any products considered "Portable" including items listed below. These products should be taken to the Service Agency for repair:

- * The Model 510FD, 510FF Fryer.
- * The Model 526TOA Toaster Oven.
- * The Model J4R, 4 oz. Popcorn Machine.
- * The Model 518CMA & 526CMA Cheese Melter.
- * The Model 12MC & 15MC & 18MCP Hot Food Merchandisers.
- * The Model 12NCPW & 15NCPW Nacho Chip/Popcorn Warmer.
- * All Hot Dog Equipment **except Roller Grills & Drawer Bun Warmers.**
- * All Nacho Cheese Warmers **except Model 11WLA Series Nacho Cheese Warmer.**
- * All Condiment Dispensers **except the Model HPD & SPD Series Dispenser.**
- * All Specialty Food Warmers **except Model 130R, 11RW Series, and 11WSA Series.**
- * All QCS/RCS Series Toasters **except Model QCS3 & RCS3 Series.**
- * All Fast Steamer Models **except Direct Connect Series.**

ALL:

- * Pop-Up Toasters
- * Butter Dispensers
- * Pretzel Merchandisers
(Model 16PD-A Only)
- * Pastry Display Cabinets
- * Nacho Chip Merchandisers
- * Accessories of any kind
- * Sneeze Guards
- * Pizza Ovens
(Model PO12 Only)
- * Heat Lamps
- * Pumps-Manual

The foregoing warranty is in lieu of any and all other warranties expressed or implied and constitutes the entire warranty.

FOR ASSISTANCE

Should you need any assistance regarding the Operation or Maintenance of any Star equipment; write, phone, fax or email our Service Department. In all correspondence mention the Model number and the Serial number of your unit, and the voltage or type of gas you are using.

MATERIAL		FINISH		MODEL NO.		PART NO.	
				35SS, 35S		SK1616	
DR. R.T. CK.	DATE 1-7-66	STAR MFG. INTERNATIONAL, INC.				WIRING DIAGRAM	
LIMITS UNLESS OTHERWISE NOTED		9325 OLIVE BOULEVARD ST. LOUIS, MO 63132				TITLE	
FRACTIONS ± 1/64 DECIMALS .005 ±						CHANGES	
				LTR	DATE	CHANGE	DR
				A	10-31-74	ADDED WIRE SIZE NOTE.	MM
				B	4-28-78	REMOVED WORD "PROBE" BEFORE "THERMOSTAT"	RT
				C	10-10-88	ADDED 36SS	TH
				D	11-03-98	REDRAWN TO ACAD14, ADDED FUSES	MP

NOTES:
1. ALL INTERNAL WIRING - #16 GA.

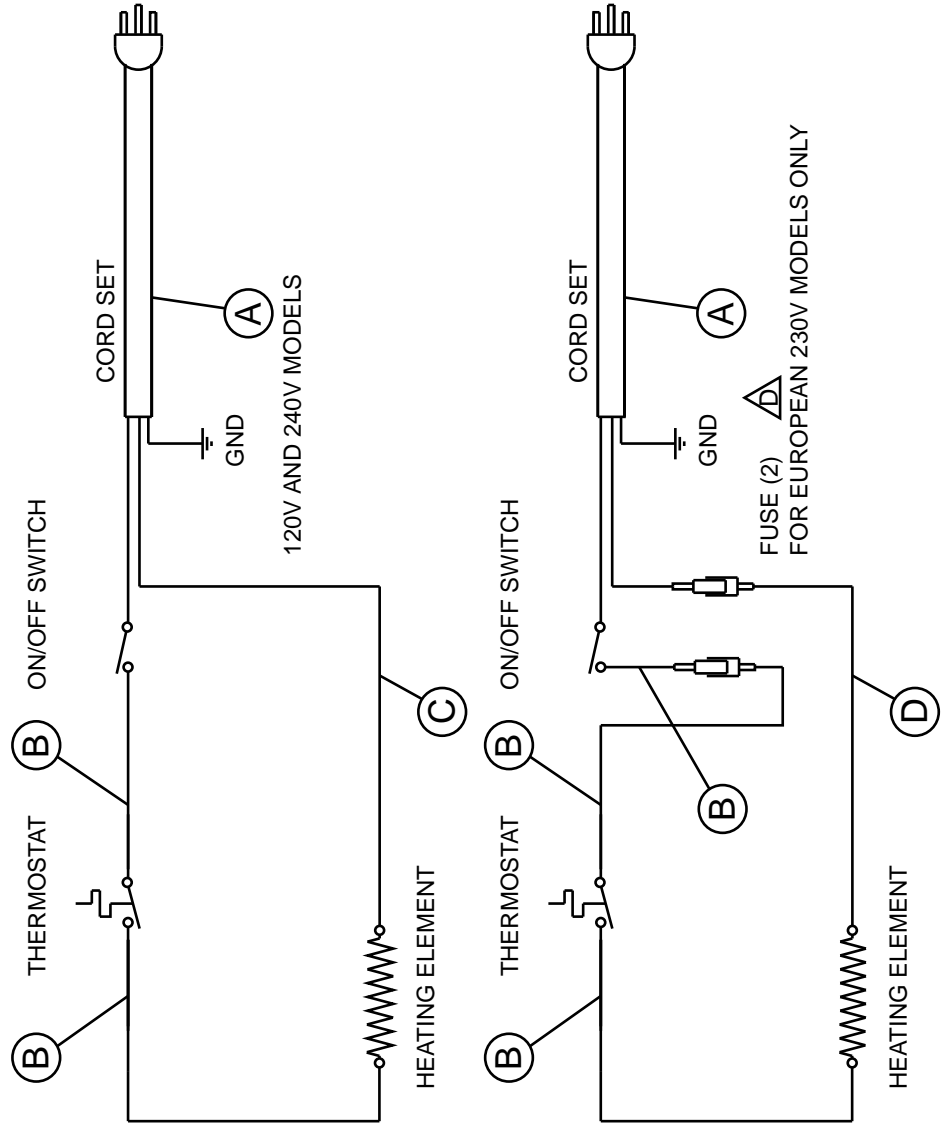

HOT DOG STEAMER: 35SSC

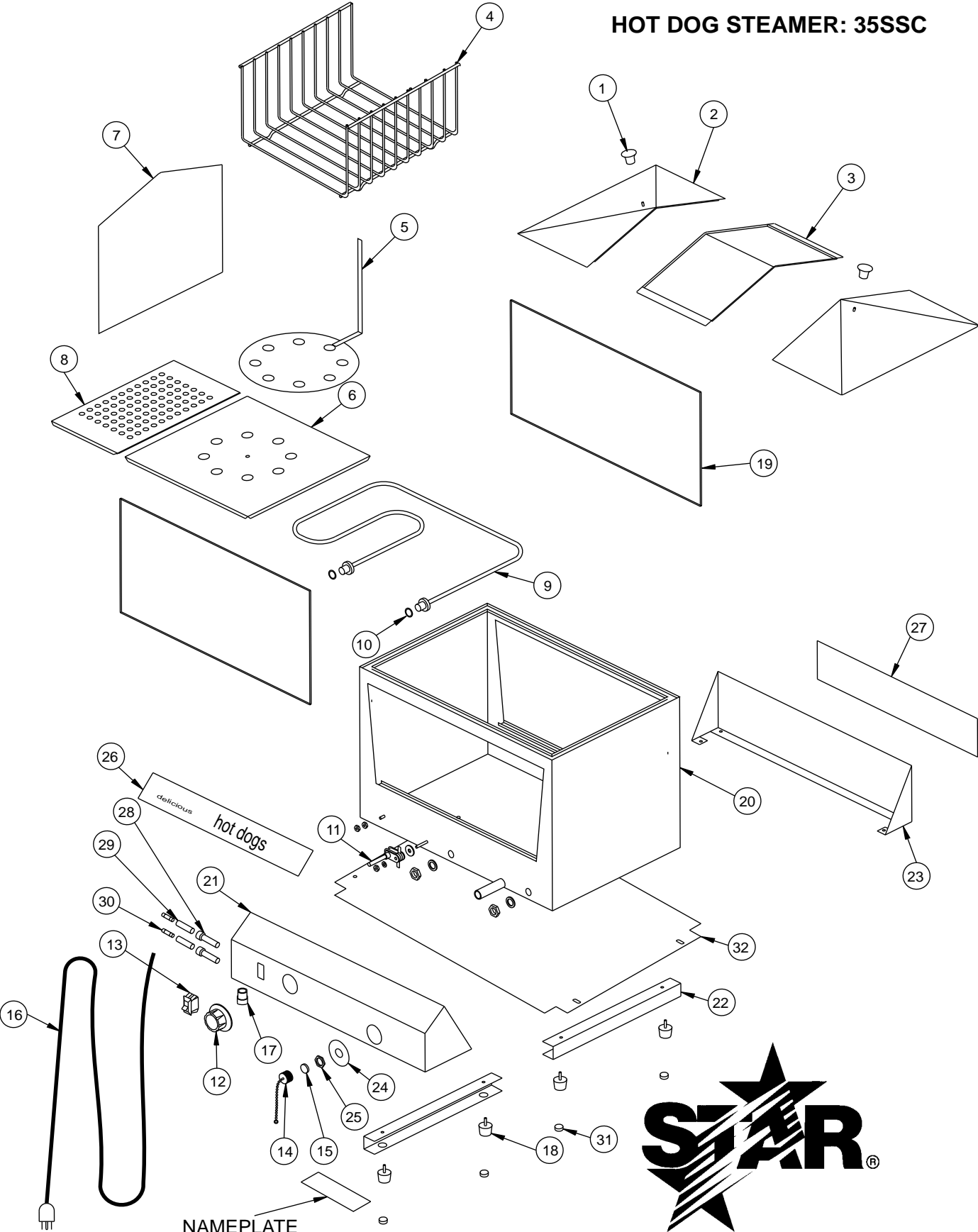

PARTS LIST

June 11, 2012

MODEL 35SSC Steamro, Jr. Classic

Key Number	Part Number	Number Per Unit	Description
1	2R-Z0872	2	KNOB
2	A3-35319	2	END LID ASSEMBLY (INCLUDES KNOB)
3	A3-Y6558	1	COVER - CENTER
4	A3-Z6694	1	BUN RACK ASSEMBLY
5	A3-35312	1	HUMIDITY CONTROL ASSEMBLY
6	A3-Y6388	1	TRAY - BUN
7	A3-Y6384	1	PARTITION
8	A3-Y6383	1	TRAY - HOT DOG
9	2N-Y6366	1	ELEMENT 1000W 120V
	2N-Z2796	1	ELEMENT 1000W 240V (CE MODEL)
10	2I-Y6404	2	O'RING (ELEMENT)
11	2T-Z4189	1	THERMOSTAT
12	2R-Y6353	1	KNOB - THERMOSTAT
13	2E-Y6144	1	SWITCH
14	A3-35219	1	CAP AND CHAIN ASSY (INCLUDES GASKET)
15	2I-9772	1	GASKET - CAP AND CHAIN
16	A3-35314	1	CORD ASSY 120V
	A3-35321	1	CORD ASSY 230V CE
17	2K-7889	1	BUSHING - CORD
18	2A-Y3405	4	FOOT
19	2Q-Y6393	2	GLASS - PLATE (8 1/4" x 17 3/4" x 1/8" DBL STRENGTH) REPLACEMENT GLASS CAN BE PURCHASED LOCALLY
20	PS-35311	1	BODY ASSEMBLY
21	A3-35316	1	CONTROL PANEL ASSEMBLY ON 120V AND 240V MODELS
	A3-35322	1	CONTROL PANEL ASSEMBLY ON 230V CE MODEL
22	A3-Y6391	2	RAIL - BASE
23	A3-Y6395	1	REAR - BASE
24	2M-Y6402	1	COVER PLATE
25	2C-Y6403	1	JAM NUT
26	2M-Y6513	1	SIGN - HOT DOGS REAR (Operator) 2"
27	2M-Y6512	1	SIGN - HOT DOGS FRONT (Customer) 3"
28	2E-Z2145	2	FUSEHOLDER 230V CE MODELS
29	2E-Z2146	2	FUSEHOLDER 230V CE MODELS
30	2E-Z2148	2	FUSE 5A 250V 230V CE MODELS
31	2P-Y3404	4	PLUG - RUBBER
	8A-35T	1	ACCESSORY, JUICE TRAY (optional)
	A3-35225	1	HOT DOG JUICE TRAY WITH RACK (optional)
	PS-35217	1	HOT DOG JUICE TRAY ONLY (optional)
	A3-35218	1	HOT DOG JUICE RACK ONLY (optional)

**IMPORTANT: WHEN ORDERING, SPECIFY VOLTAGE OR TYPE GAS DESIRED
INCLUDE MODEL AND SERIAL NUMBER**

PAGE 1
OF 1

Some items are included for illustrative purposes only and in certain instances may not be available.



Star Manufacturing International, Inc.

STAR INTERNATIONAL HOLDINGS INC. COMPANY
Star - Holman - Lang - Wells - Bloomfield - Toastmaster
10 Sunnen Drive, St. Louis, MO 63143 U.S.A.
(314) 678-6303
www.star-mfg.com