

**ASSEMBLY INSTRUCTIONS**

**Geneva Bookcase**

**Model #: 6278-120**

Made in China

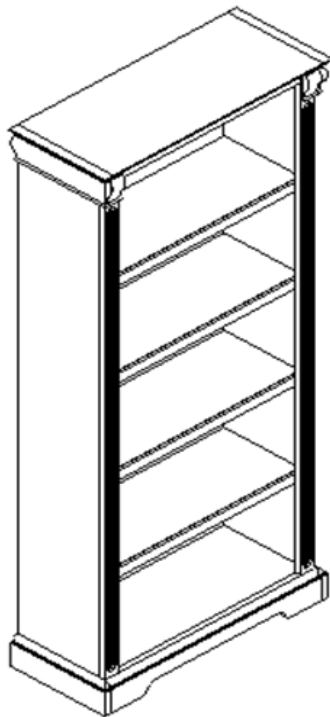

**THIS INSTRUCTION  
BOOKLET CONTAINS  
IMPORTANT SAFETY  
INFORMATION. PLEASE  
READ AND KEEP FOR  
FUTURE REFERENCE.**

Lot Number: \_\_\_\_\_

Date Purchased: \_\_\_\_\_



**DO NOT RETURN YOUR UNIT  
TO THE STORE**

**CONTACT US FIRST**

For FAST, FRIENDLY and EFFICIENT service call:

**Toll Free: 1-800-782-3876**

(8:00am-5:00pm Monday-Friday ET)

United States and Canada (except holidays)

**Or email: [RTAHELP@furniturebrands.com](mailto:RTAHELP@furniturebrands.com)**

*Most replacement parts ship from our facility in two  
or three business days.*

## **NOTE:**

- It is recommended that two people assemble this case.
- Note the arrow direction on each panel when assembling the case.

READ THE INSTRUCTIONS before you begin assembly, read the instructions carefully. We suggest starting with the subassembly of the parts before beginning the main assembly.

IDENTIFY THE PIECES AND HARDWARE. First, lay all the parts and hardware out on the floor surface (preferably on carpet) as you see them in the Parts List. This will help you locate the right item when you need it. NOTE: SOME PARTS MAY NOT BE IDENTIFIED WITH LABELS.

If you have any questions about your new furniture, just call 1 800 RTA-FURN (1 800 782-3876) between 8:00a.m. - 5:00 p.m., Monday through Friday (Eastern Time). Holidays and weekends will not be staffed. IMPORTANT: Have the part number handy when you call.

## **Furniture Care & Maintenance**

To remove part labels, gently rub a soft cloth moistened with a mild household cleanser (Windex or Pledge) over the part label. Then lift a corner of the label and pull firmly but smoothly until the label comes off..

- Use a soft, clean cloth that will not scratch the surface when dusting.
- Use of furniture polish is not necessary. Should you choose to use polish, test in an inconspicuous area.
- Using solvents of any kind on your furniture may damage the furniture's finish.
- Never use water to clean your furniture as it may cause damage to the furniture's finish.
- Always remember to use coasters under beverage glasses..
- Liquid spills should be removed immediately. Using a soft clean cloth, blot the spill gently and avoid rubbing.
- Always use protective pads under hot dishes or plates. Heat can cause chemical changes that may create spotting with the furniture finish.
- Stains or marks from crayons or ink markers will be difficult to remove.
- In the event your furniture is stained or otherwise damaged during use, we recommend that you call a professional to repair your furniture.
- Check bolts/screws periodically and tighten them if necessary.

## **Further Advise About Wood Furniture Care**

It is best to keep your furniture in a climate-controlled environment. Extreme temperature and humidity changes can cause fading, warping, shrinking and splitting of wood. It is advised to keep furniture away from direct sunlight as sun may damage the finish. Proper care and cleaning at home will extend the life of your purchase.. Follow the important and helpful tips that will enhance your furniture as it ages. A Touch-up pen has been provided to repair any small nicks or scratches that may occur during assembly or shipping.

Please read completely through the instructions and verify that all parts listed are present before beginning assembly. **IF YOU NEED ASSISTANCE WITH ASSEMBLY OR TO ORDER PARTS, PLEASE USE THE LIST BELOW AND CALL 1-800-782-3876 AND REFERENCE MODEL#: 6278-120**

## Component Part List





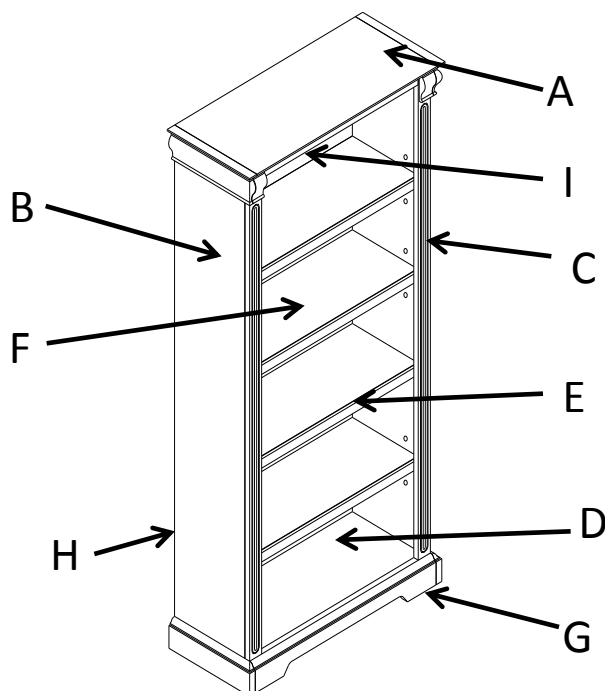





ITEM	DESCRIPTION	PART NUMBER	QUANTITY
A	Top Panel	80186769	1
B	Left Side Panel	80186770	1
C	Right Side Panel	80186771	1
D	Bottom Panel	80186772	1
E	Middle Shelf Panel	80186773	1
F	Adjustable Shelf	80186774	3
G	Front Bottom Stretcher	80186775	1
H	Back Bottom Stretcher	80186776	1
I	Top Rail	80186777	1
J	Back Panel	80186778	1

**NOTE: A Phillips Screwdriver will be needed for assembly.**



Please read completely through the instructions and verify that all parts listed are present before beginning assembly. **IF YOU NEED ASSISTANCE WITH ASSEMBLY OR TO ORDER PARTS, PLEASE USE THE LIST BELOW AND CALL 1-800-782-3876 AND REFERENCE MODEL#: 6278-120**

## Hardware List

ITEM	IMAGE	DESCRIPTION	PART NUMBER	QUANTITY	
1		Allen Wrench	80187057 (In Blister Pack)	1	
2		Allen Bolt		20	
3		Flat Washer		20	
4		Spring Washer		20	
5		Wood Dowel		20	
6		Shelf Pin		12	
7		Screw		34	
8		Metal Plate		1	
9		Touch Up Marker		80187044 (In Blister Pack)	1
10		Tipping Restraint		80187058	1

## **Step 1**

Insert Wood Dowel (5) into Right Side Panel (C).

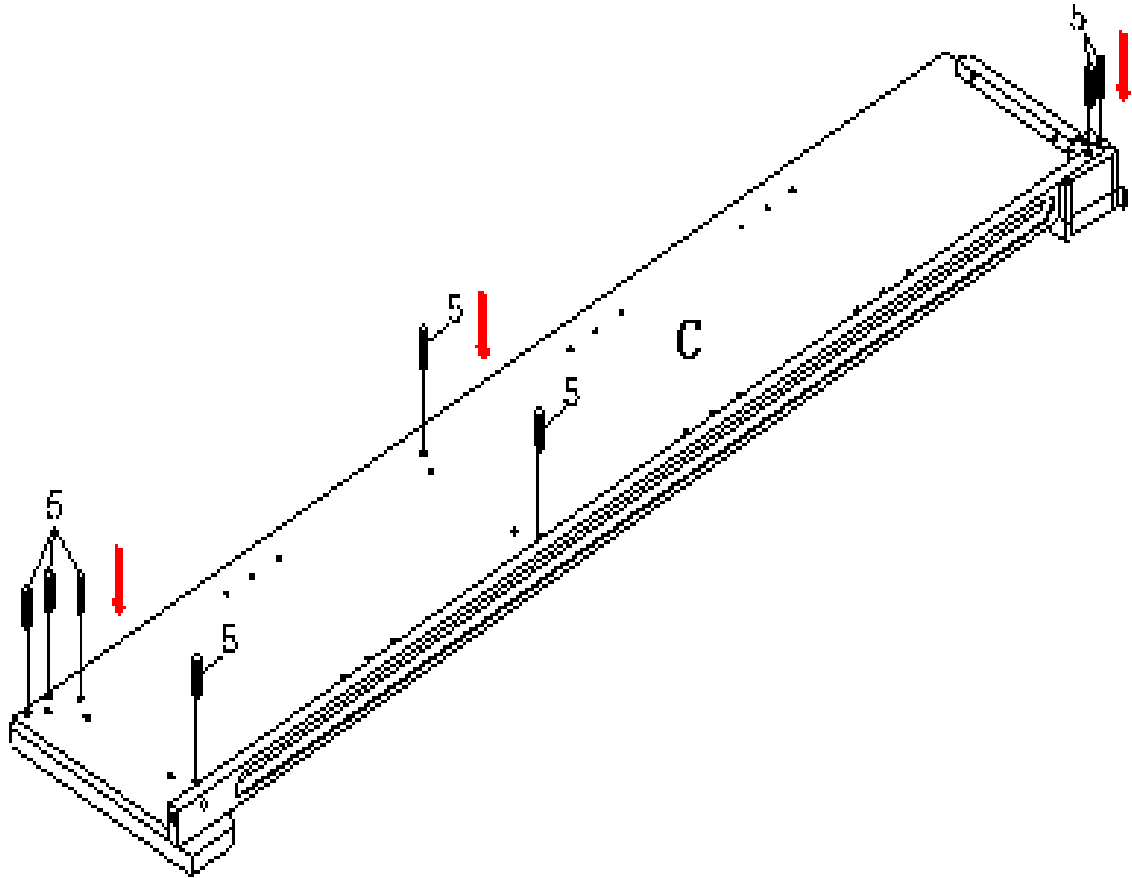

## Step 2

1. Align and insert the Top Rail (I), Middle Shelf Panel (E), Bottom Panel (D), Back Bottom Stretcher (H) with Wood Dowel (5) to connect to Right Side Panel (C).
2. Connect Spring Washer (4), Flat Washer (3), to Allen Bolt (2). Hand tighten or use Allen Wrench (1) to lightly connect Allen Bolt (2) - do not secure too tight at this step.

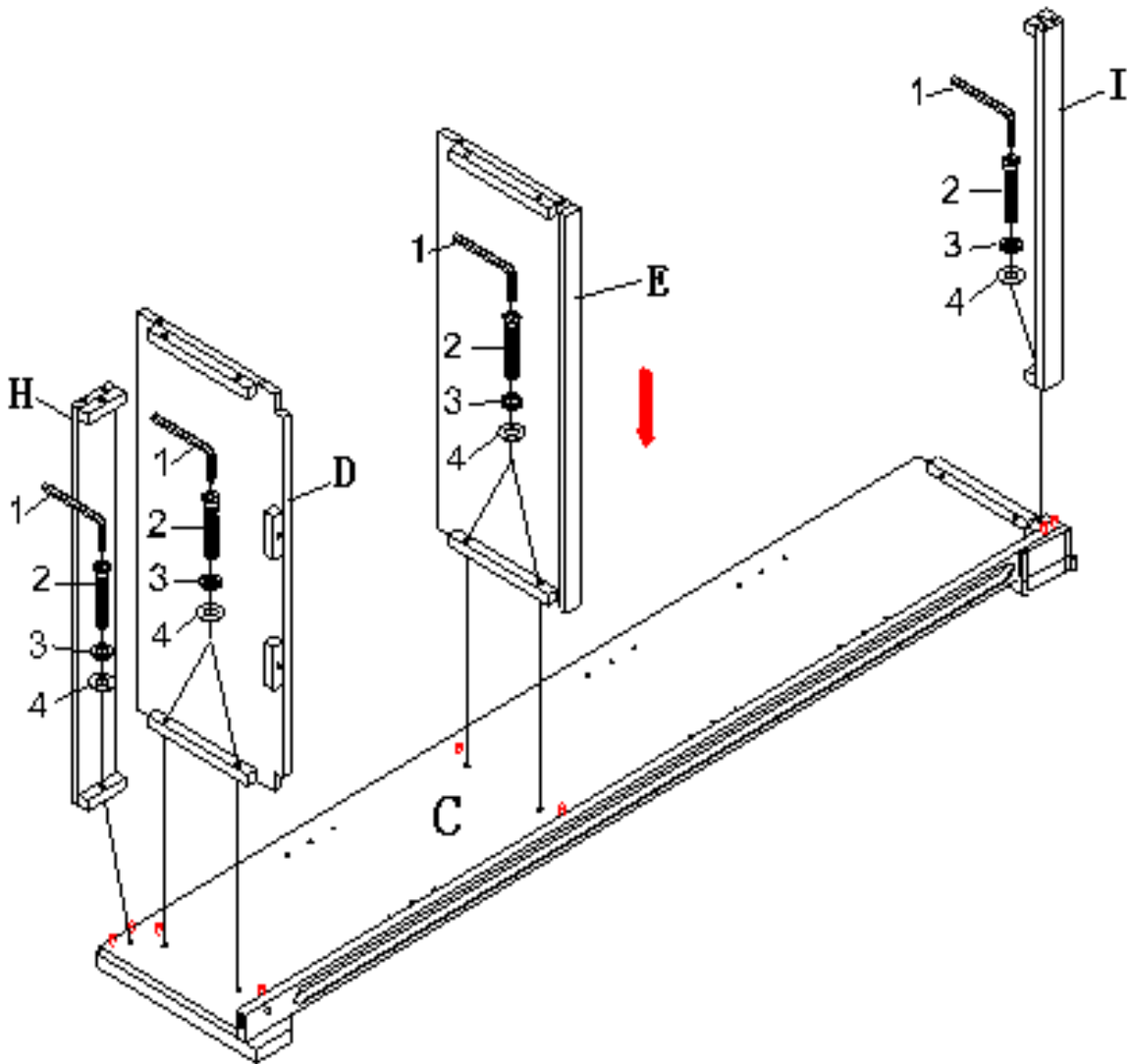

### **Step 3**

Insert Wood Dowels (5) into Top Rail (I), Middle Shelf Panel (E), Bottom Panel (D), Back Bottom Stretcher (H).

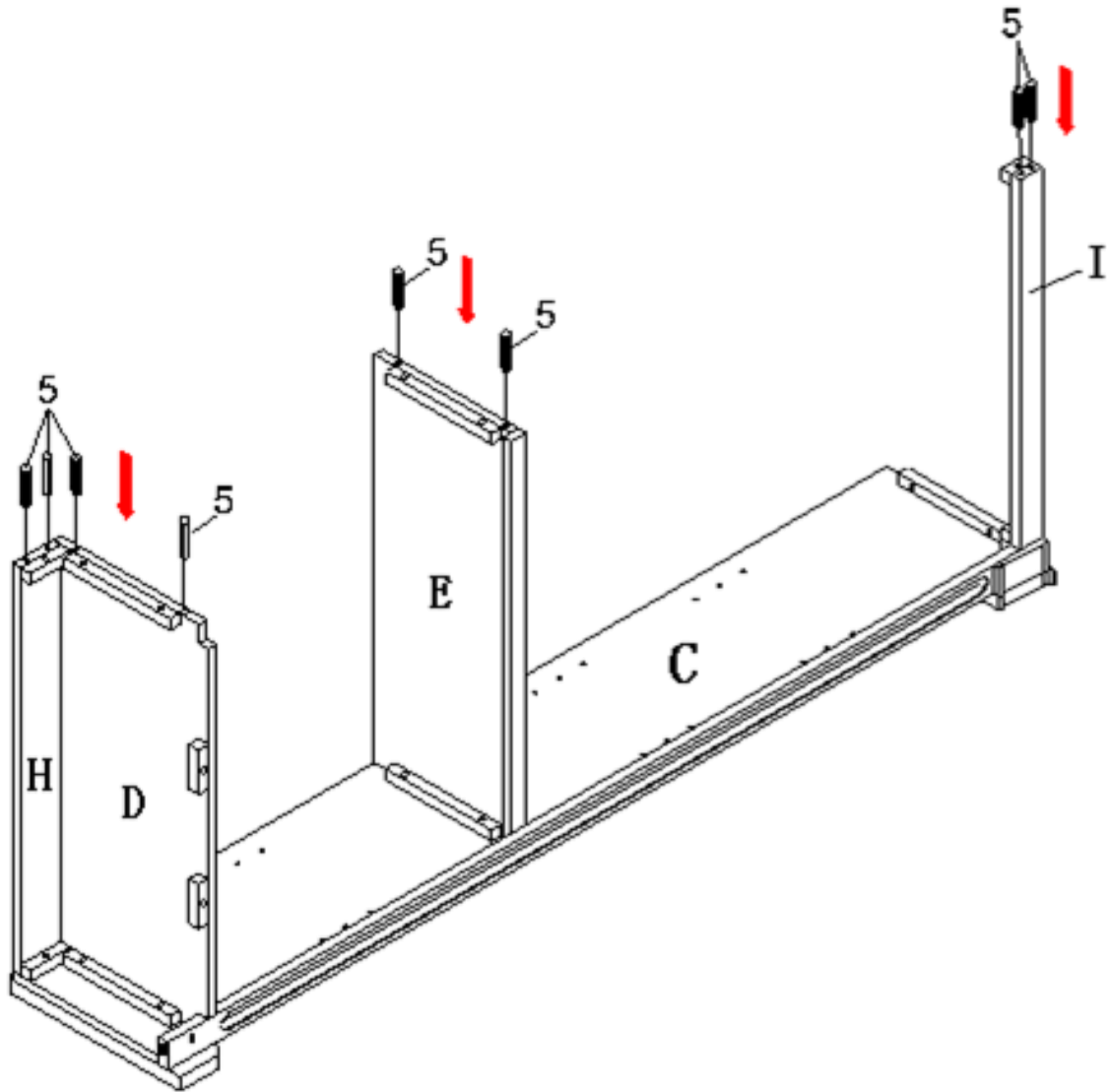





## **Step 5**

Insert Wood Dowel (5) into both Left and Right Side Panel (B/C).

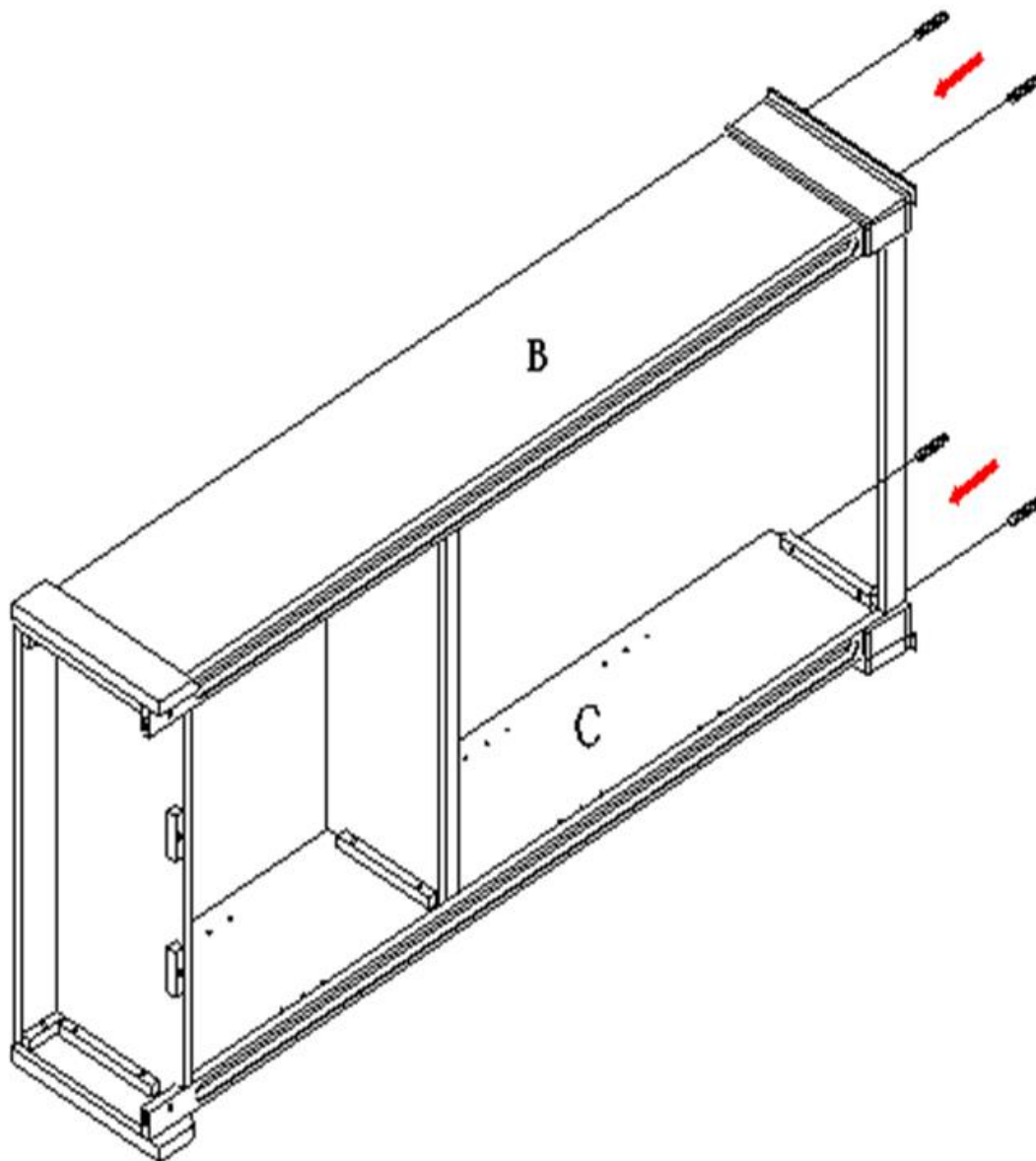

## Step 6

1. Make sure Top Panel (A) is aligned with Wood Dowel (5) to connect Left Side Panel (B).
2. Connect Top Panel (A) to Left and Right Side Panels (B/C).
3. Connect Spring Washer (4), Flat Washer (3), to Allen Bolt (2). Hand tighten or use Allen Wrench (1) to lightly connect Allen Bolt (2) - do not secure too tight at this step.

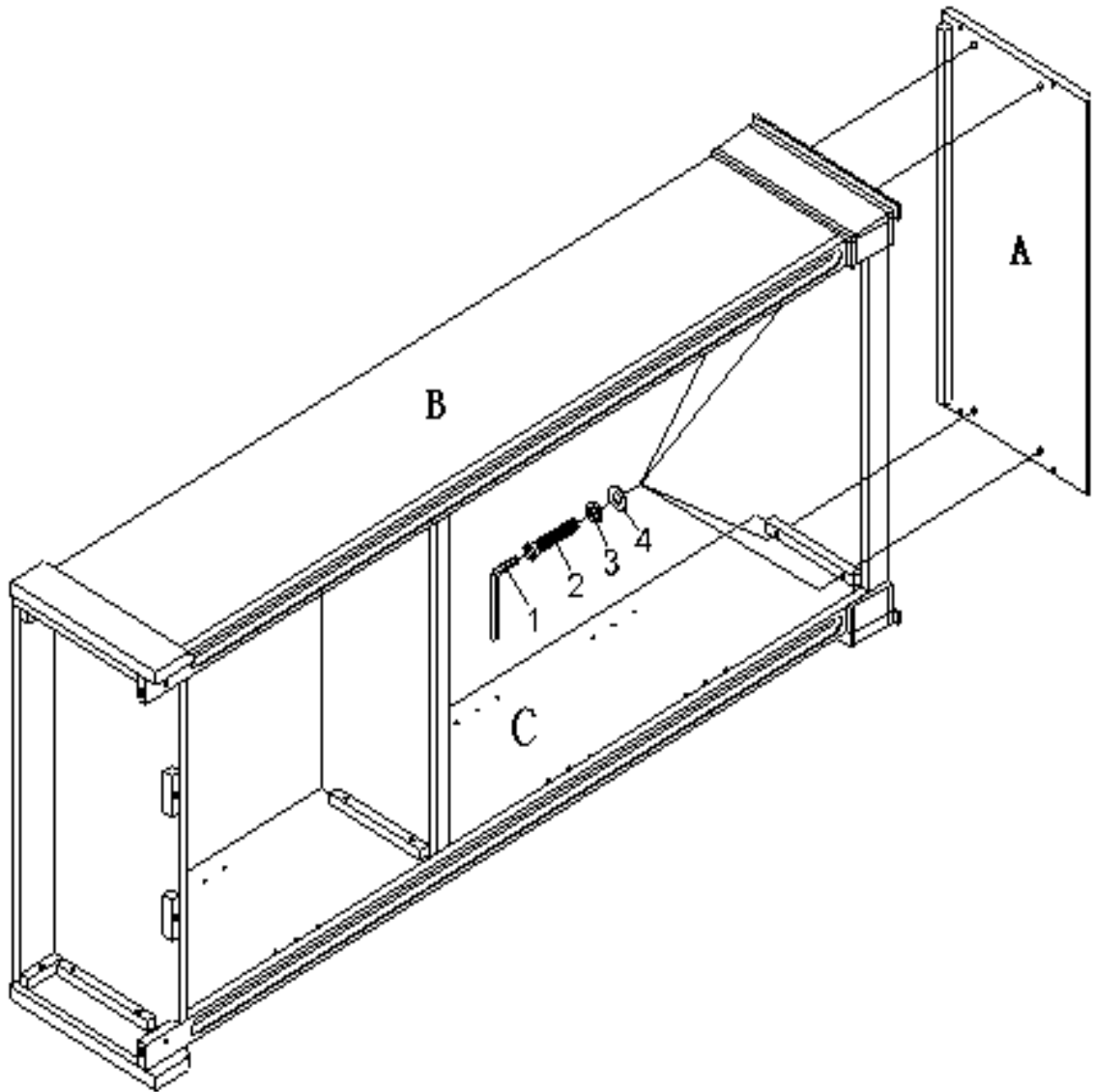

## Step 7

1. Using Allen Wrench (1), Connect Spring washer (4), Flat Washer (3) to Allen Bolt (2).
2. Use Allen Bolt (2) to secure Front Bottom Stretcher (G).
3. IMPORTANT: At this step, all hand tightened bolts in the previous steps should be secured tightly with the Allen Wrench (1).

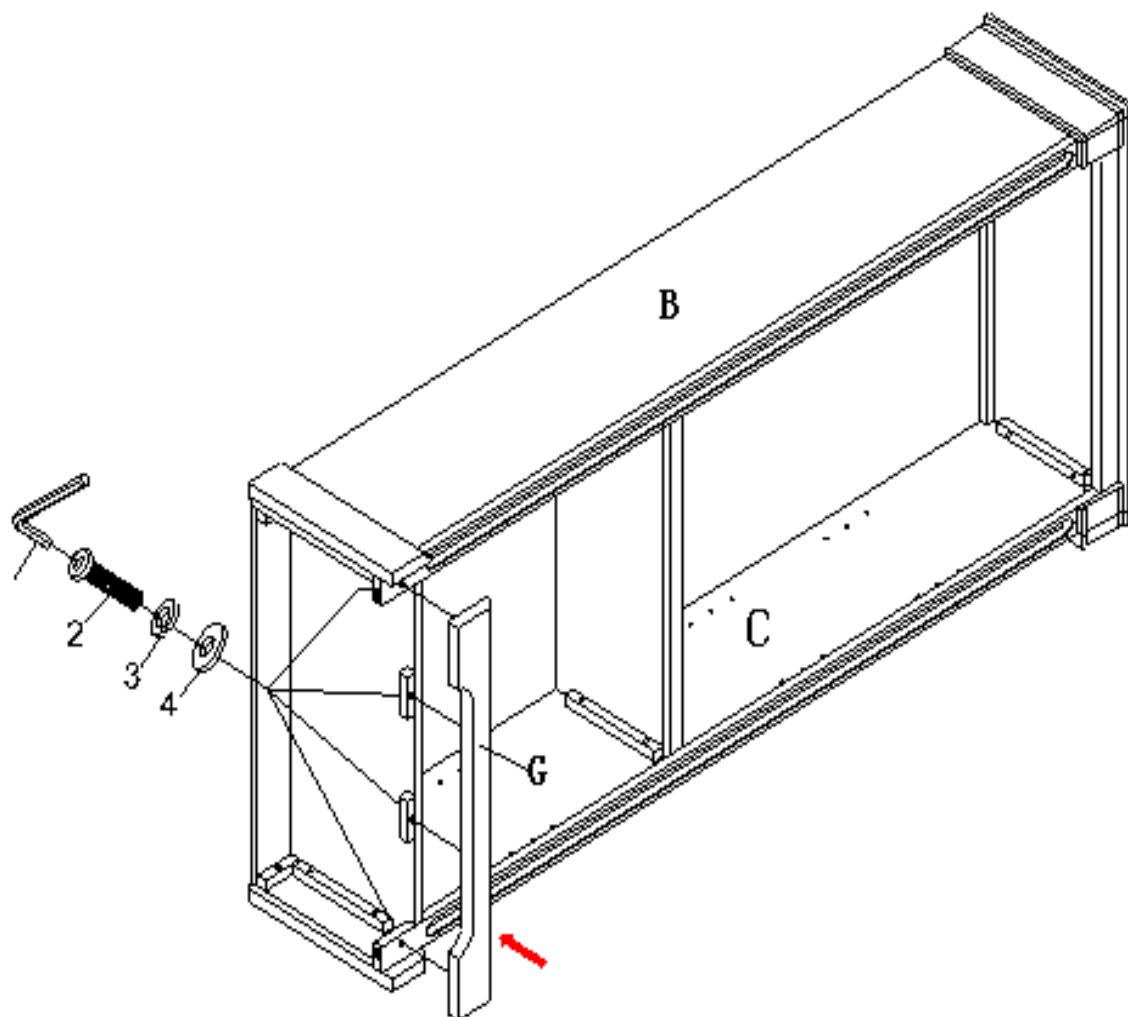

## Step 8

Use Phillips Screwdriver (11) to attach Back Panel (J) to the bookcase using Screw (7).

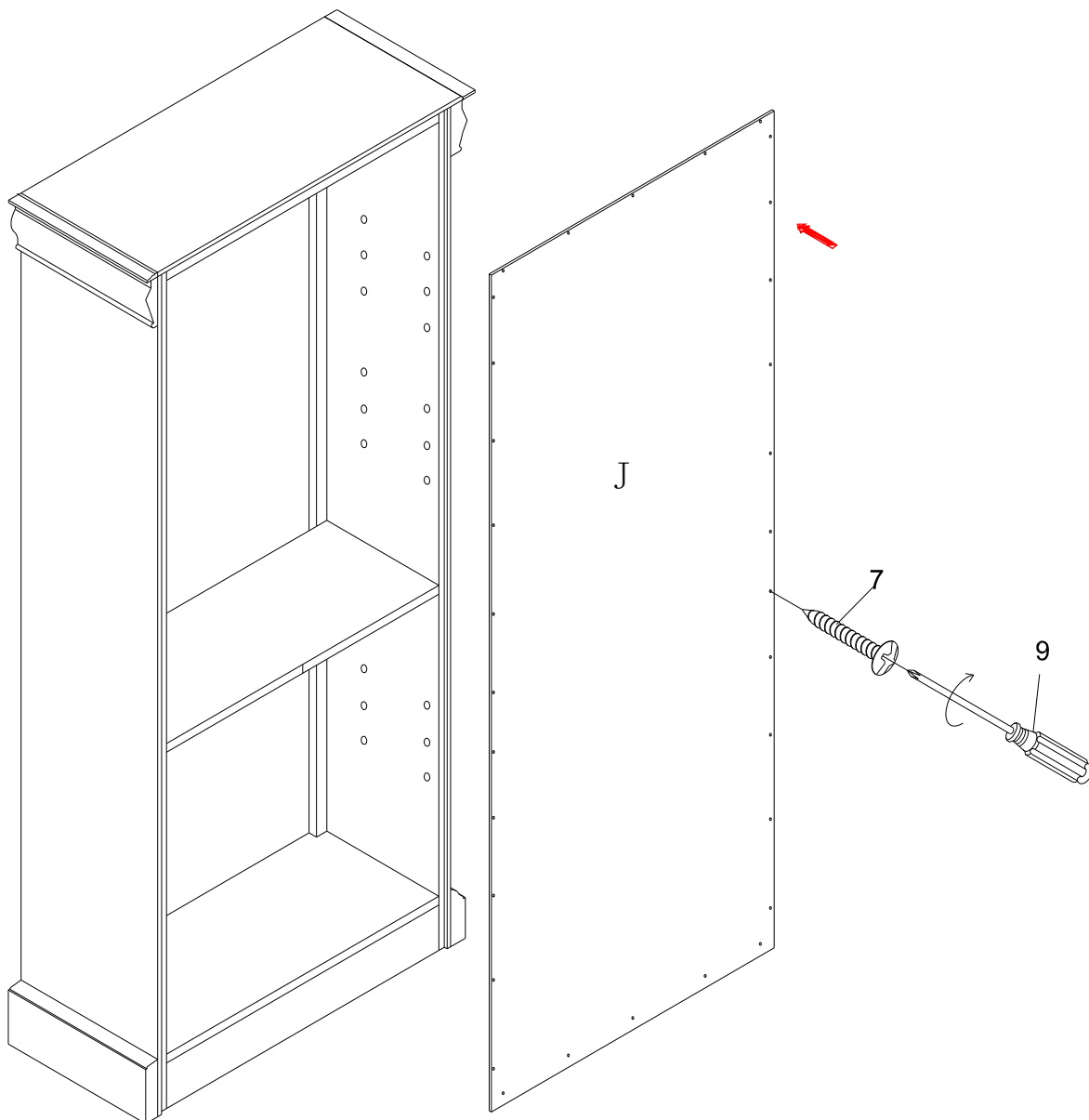

## Step 9

1. Insert Shelf Pin (6) into Left and Right Side panels (B/C).
2. Place Adjustable Shelf (F) on pins in desired locations.
3. Underneath front bottom panel corners are two adjustable foot levers. You may need to adjust the bottom foot pad as shown in diagram to keep the bookcase in level position on even floors.

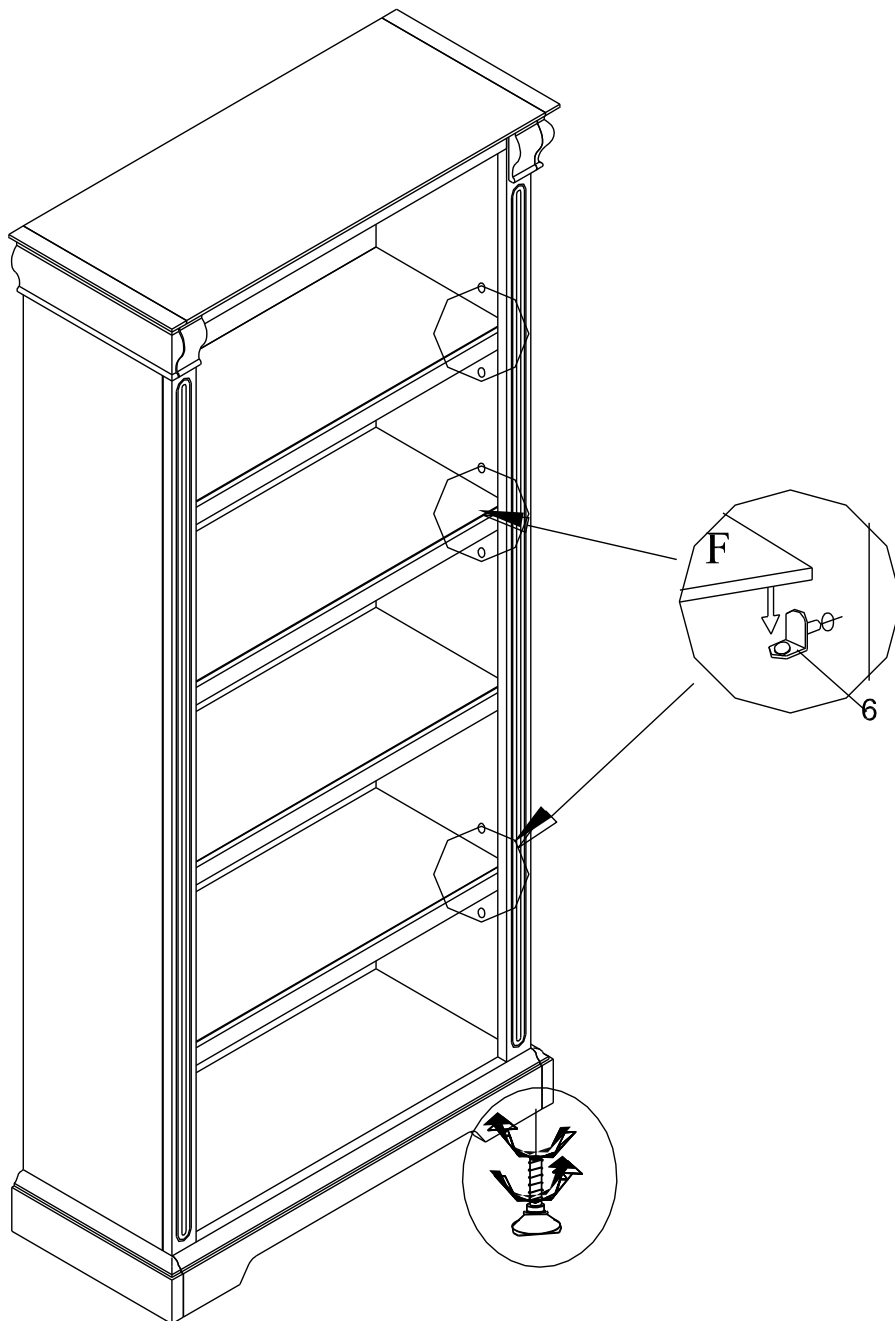

## Step 10

1. If two bookcases are placed side-by-side, use Allen Wrench (1) to take off both top and bottom decorative moldings of the corresponding sides shown in below diagram A.
2. We have included a Metal Plate (7) for securing the bookcases together side-by-side. When installing the Metal Plates(7), use the pre-drilled holes on the top of the bookcases and the screws packed with the Metal Plate (7) as shown below in diagram B.

Diagram A

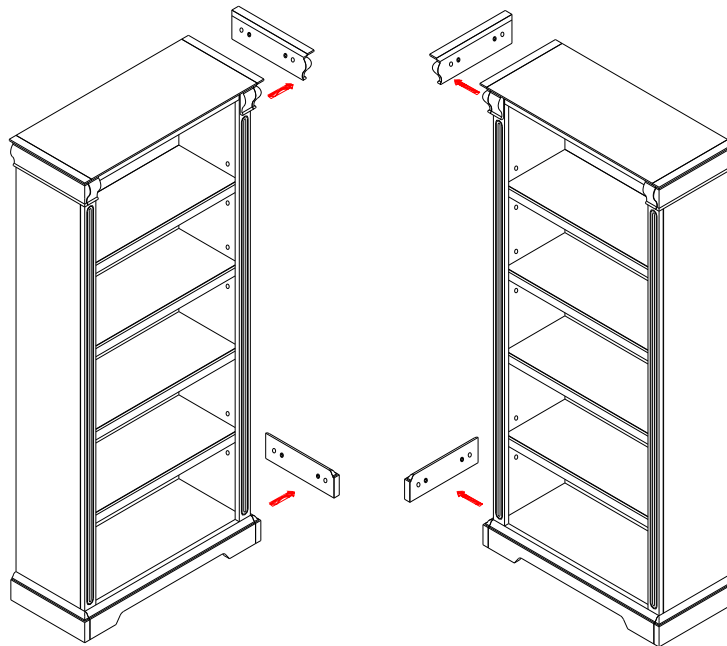
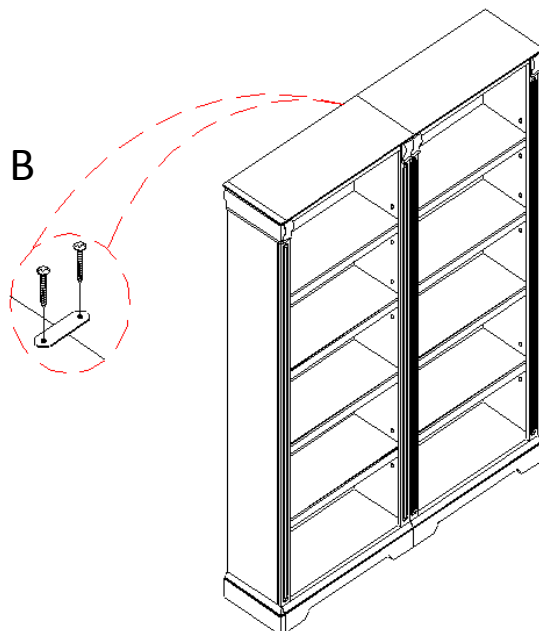
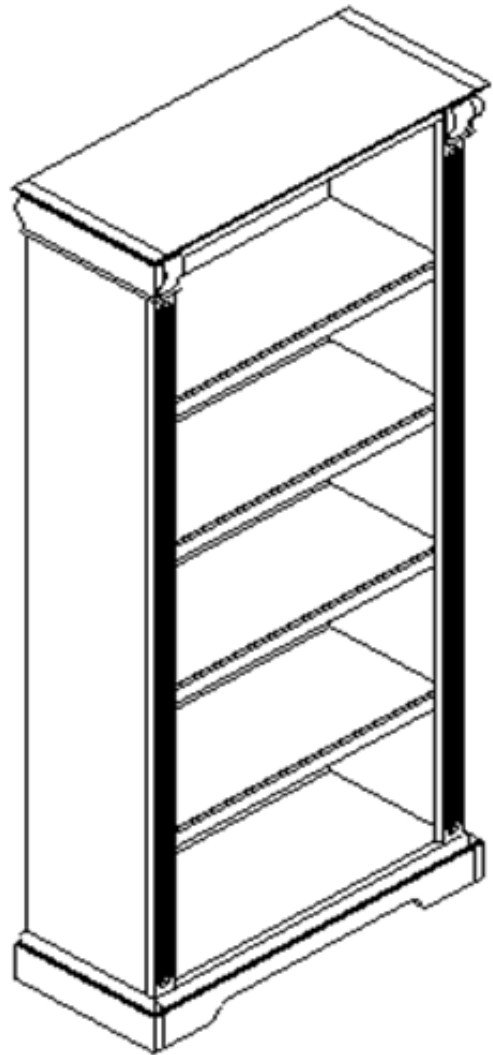
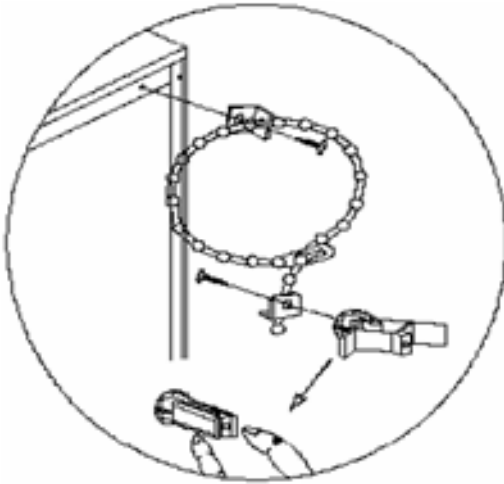

Diagram B



## **Step 11 – TIPPING RESTRAINT HARDWARE**

Note: We have included a Tipping Restraint Hardware bag (part 8) for this Unit. You must install this hardware to prevent accidents or injuries from falling unit. Attach the device to the back of the cabinet and to the wall using the instructions on the bag.



**⚠ WARNING**

**WE HAVE INCLUDED A TIP-OVER RESTRAINT FOR THIS UNIT (8). PLEASE READ INSTRUCTIONS ON BAG CAREFULLY BEFORE INSTALLING.**

**YOUNG CHILDREN MAY BE INJURED BY TIPPING FURNITURE AND THE USE OF ENCLOSED TIP-OVER RESTRAINT IS HIGHLY RECOMMENDED TO PREVENT TIP-OVER. THIS HARDWARE, WHEN PROPERLY INSTALLED, COULD PROVIDE PROTECTION AGAINST THE UNEXPECTED TIPPING OF FURNITURE DUE TO IMPROPER USE, SMALL TREMORS, BUMPS AND CLIMBING.**

**NEVER ALLOW CHILDREN TO CLIMB OR HANG ON SHELVES. USE OF TIP-OVER RESTRAINTS MAY ONLY REDUCE, BUT NOT ELIMINATE, THE RISK OF TIP-OVER. IT IS NOT A SUBSTITUTE FOR PROPER ADULT SUPERVISION.**

**WE STRONGLY RECOMMEND MOUNTING THIS HARDWARE TO A WALL STUD AND YOUR BOOKCASE.**

**⚠ WARNING**

**THIS UNIT IS INTENDED FOR USE ONLY WITH THE MAXIMUM WEIGHTS INDICATED. USE WITH PRODUCTS HEAVIER THAN THE MAXIMUM WEIGHTS INDICATED MAY RESULT IN INSTABILITY CAUSING POSSIBLE INJURY**

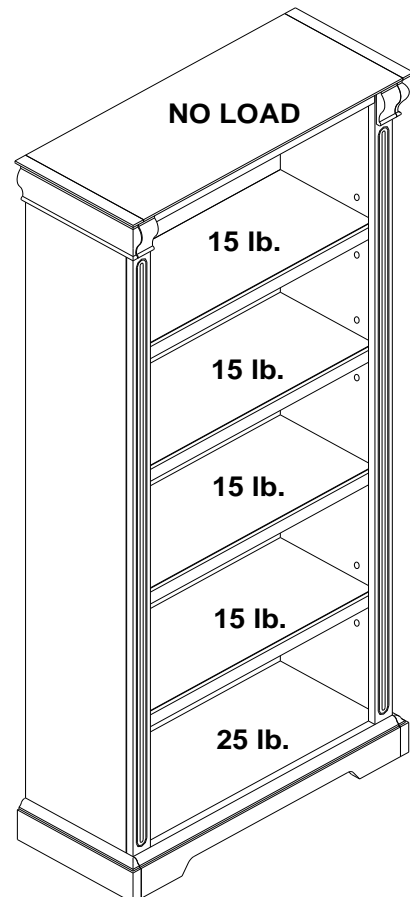



**Thomasville**<sup>®</sup>  
special additions™

## ASSEMBLY INSTRUCTIONS

### Geneva Bookcase

Model #: 6278-120

Made in China

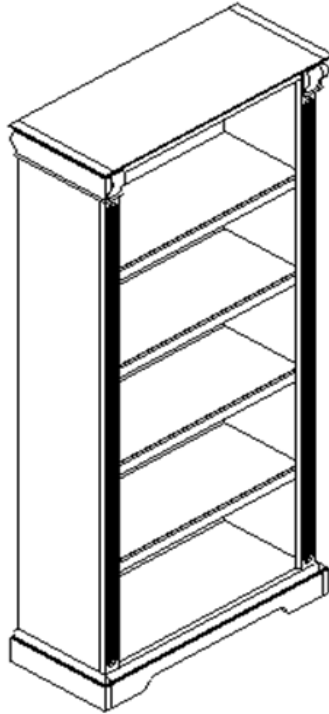

**IF YOU NEED ASSISTANCE WITH ASSEMBLY OR TO ORDER PARTS, PLEASE CALL 1-800-782-3876  
AND REFERENCE THE MODEL #.**

### One Year Limited Warranty

*We warrant to you, the original purchaser, a one year limited warranty. We will repair or replace any piece of furniture which is defective in materials or workmanship. For more detailed information on the product warranty you may contact us at 1-800-782-3876.*



a Division of Thomasville Furniture Industries, Inc.

401 E. Main St.

Thomasville, NC 27361